



Product catalog 2020
Valid from May

Fire Alarm Systems

Contents

	General Information	3-5
	General Information	3-5
1	Control Panels	7-28
	IQ8Control	8-24
	Extinguishing System	25-28
2	Power Supplies	29-34
	Power Supply Units	30-32
	Voltage Converters	33
	Batteries (Rechargeable)	34
	Accessories	34
3	Displays and Operating Units	35-38
	LED Indicator Panel	36
	LCD Indicator Panel	37
	System 3000	38
4	Network Technology	39-44
	essernet	40-44
5	Hazard Management System	45-56
	WINMAGplus	46-54
	WINMAGLite	55
	Difference WINMAGLite vs WINMAGplus	56
6	Automatic Detectors	57-93
	Series ES Detect (Conventional)	58-61
	Series IQ8Quad (Intelligent Addressable)	62-73
	Intrinsically Safe	74-79
	Base Series IQ8Quad, ES Detect	80
	Accessories	81-93
7	Manual Call Points	95-118
	Large Design (ABS)	96-99
	Accessories for MCP large design	100-103
	Small Design (ABS)	104-110
	Accessories for MCP small design	111-112
	Special Design	113-118
8	Transponders / Input & Output Modules	119-132
	esserbus	120-132
9	Wireless Components	133-140
	Wireless Modules	134-140

Contents

10	Detectors for Special Applications	141-188
	Flame and Heat Detectors	142-149
	Air Duct Detectors	150-152
	Linear Heat Detectors	153-159
	Linear Smoke Detectors	160-167
	Aspirating Smoke Detectors	168-187
11	Alarm Devices	189-210
	Conventional ENscape	190-196
	Intelligent Addressable IQ8Alarm Plus	197-208
	Intrinsically Safe	209
	Remote Indicators	210
12	Door Release System	211-217
	Door Holding Devices	212-216
	Triggering Devices	217
13	Installation & Service	219-226
	Installation Accessories	220-224
	Housings	225-226
14	Appendix	227-245
	Planning Guide	228
	Order Forms	229-236
	Part Number Index	237-239
	Index	240-247

Contact us

Headquarters

Honeywell Life Safety Austria GmbH

Technologiestrasse 5,
1120 Vienna, Austria
Phone: +43 1 600 60 30
E-mail: hls-austria@honeywell.com
Internet: www.hls-austria.com

Czech Republic / Slovakia

Honeywell, spol. s r.o.
V Parku 2325/16
148 00 Prague 4 - Chodov, Czech Republic
Phone: +420 242 442 280
E-mail: hls-czech@honeywell.com
Internet: www.hls-czech.com

Poland

Honeywell Sp.z.o.o.
Nefryt Building
ul. Domaniewska 39
02-672 Warsaw, Poland
Phone: +48 22 60 60 900
E-mail: hls-poland@honeywell.com
Internet: www.hls-poland.com

Romania

Honeywell Life Safety Romania S.R.L.
Upground - BOC Office Building
Str. George Constrantinescu nr. 3, building A, 4th floor
020338 Bucharest, Romania
Phone: +40 31 224 3001
E-mail: hls-romania@honeywell.com
Internet: www.hls-romania.com

Honeywell Life Safety Romania S.R.L.
Str. Salcânilor nr. 2 bis
305500 Lugoj, Romania
Phone: +40 256 350 000
E-mail: hls-romania@honeywell.com
Internet: www.hls-romania.com

Ukraine

FE Honeywell Ukraine
Office Center „IRVA“, Block A
Radyscheva str. 10/14
03680 Kiev, Ukraine
Phone: +380 44 351 15 50
E-mail: hls-ukraine@honeywell.com
Internet: www.hls-austria.com

Croatia

Honeywell automatizacija i kontrola d.o.o.
Av. V. Holjevca 40
10000 Zagreb, Croatia
E-mail: hls-romania@honeywell.com
Internet: www.hls-austria.com

Hungary

Honeywell Szabályozástechnikai Kft.
Petneházy u. 2-4.
1139 Budapest, Hungary
Phone: +36 1 451 4300
E-mail: hls-hungary@honeywell.com
Internet: www.hls-austria.com

Abbreviations

The list below provides a brief explanation of various abbreviations used in this product guide.

ABIGA	= integrated operating unit for alarm systems	I/O	= input / output
Acc.	= according to	IP	= ingress protection rating
Approx.	= approximately	IR	= infrared
ATEX	= EU directive for explosive atmosphere	LAN	= local area network
BOSEC	= Belgian institute for the approval of fire alarm-related products	LCD	= liquid crystal display
BTS	= base transceiver station	LED	= light emitting diode
CNBOP	= Polish research and development center for fire protection	LF	= low frequency
DIBt	= German institute for technical approvals	LKM	= air duct detector
DIL	= dual in line	LPCB	= Loss Prevention Certification Board
DIN	= German institute for standardization	LRS	= high sensitivity aspiration detector
DIP	= dual in parallel	MCP	= manual call point
ECP	= extinguishing control panel	MFAB	= master box
EDP	= ESSER data protocol	MM	= micromodule
EMV	= electromagnetic compatibility	NC	= normally closed
EN	= European Norm	NO	= normally opened
EOL	= end of line	OTG	= optical, heat and gas
ESPA	= enhanced signaling protocol for alarm processes	PCB	= printed circuit board
Ex	= explosion proof / intrinsically safe	pcs.	= pieces
FACP	= fire alarm control panel	PL	= powered loop
FAS	= fire alarm system	PLC	= programmable logic control
FB	= fire brigade	PM	= delay and verify functions
FBF	= fire brigade panel	PTB	= national institute of natural and engineering sciences
FBOIU	= fire brigade operating and indicating unit	PU	= packaging unit
FCT	= fire control transponder (input/output module)	ROR	= rate-of-rise heat detector
FD	= fire detection	SEI	= serial essernet interface
FDS	= fire detection system	SHV	= smoke heat ventilation module
FIBS	= fire brigade operating system	SMD	= surface mounted technology
FO	= fiber optic	SL	= silent
FSA	= door release system	SOC	= switch-on control
GI	= galvanic isolated	SZI	= single zone indicator
HMI	= human machine interface	TAL	= technical alarm module
HU	= used for 19" rack, 1 HU = 44.45 mm	TM	= coincidence detection
		USB	= universal serial bus
		UV	= ultraviolet
		VDE	= association for electrical, electronic and information technologies
		VdS	= association of German property insurance companies
		VGA	= video graphics array
		VPP	= voltage peak-peak

Symbols used



= List of contents which the part number includes



= Packing unit



= Information, important notice
such as special versions, dependencies etc.



= Available starting on

IP type of protection

The type of protection indicates the suitability of electric operating materials (for example, devices, lights and installation material) against solid foreign objects and for various ambient conditions.

Levels of protection from contact and foreign bodies (first digit)		
Digit	Protection from contact	Protection from foreign bodies
0	No protection	No protection
1	Protection from large-sized body parts (diameter 50 mm)	Large foreign bodies (diameter from 50 mm)
2	Finger protection (diameter 12 mm)	Medium-size foreign bodies (diameter from 12.5 mm)
3	Tools and wires (diameter from 2.5 mm)	Small foreign matter (diameter from 2.5 mm)
4	Tools and wires (diameter from 1 mm)	Granular foreign matter (diameter from 1 mm)
5 (K)	Wire protection (as IP 4) dust-protected	Dust accumulation
6 (K)	Wire protection (as IP 4) dust-proof	No ingress of dust

Levels of protection from water (second digit)	
Digit	Protection from water
0	No protection
1	Protection from vertically dripping water
2	Protection from diagonally (15°) falling drip water
3	Protection from falling spray water up to 60°, against the vertical
4	Protection against splashing water
5	Protection from hose water (nozzle) from any angle
6	Protection from strong hose water (flooding)
7	Protection from temporary submersion
8	Protection from permanent submersion

Example:

IP64: Completely dust-proof – protected against splashing water – nearly leak-proof.

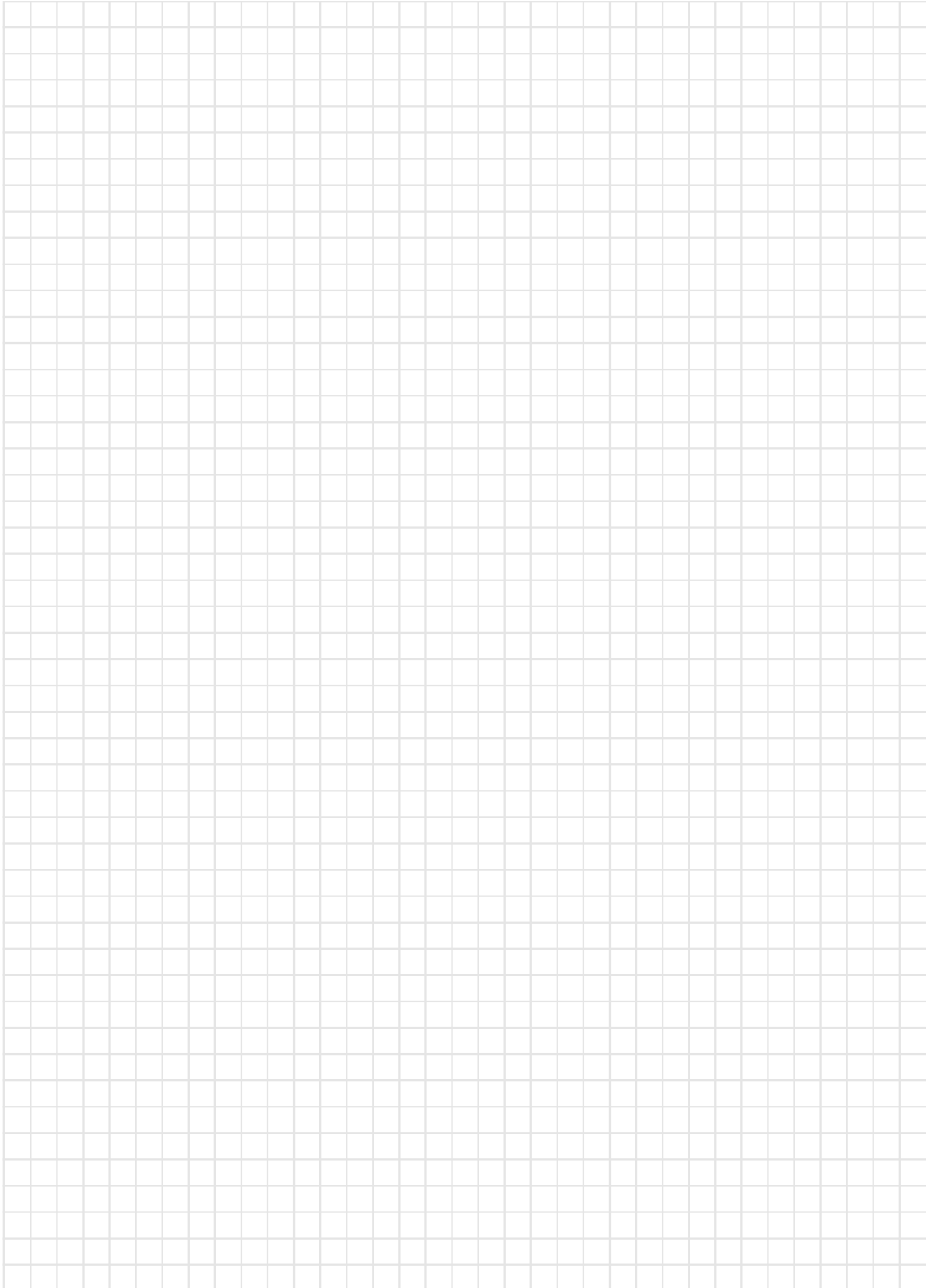



Control Panels

IQ8Control
Extinguishing System

8-24
12-28

IQ8Control C/Intelligent Addressable

Features

- Max. two micromodules (system supports up to 254 digital loop addresses in total)
- Max. two esserbus analog loop modules
- Short circuit and open circuit resistant loop operation
- Loop installation with I-Y(ST)Y 0.8 mm cable for a maximum length of 3.5 km
- Up to 127 esserbus devices (fire detectors and/or manual call points)/detector zones per loop
- Up to 32 esserbus transponders/wireless transponders per loop
- Up to 127 IQ8/FCT transponders per loop
- Operation types TM and PM as per DIN VDE 0833 - 2 to avoid unwanted alarms being triggered
- Fire brigade operating panel and alarm transmission unit interface on the peripheral module
- Three common relays, freely programmable, monitored, floating for up to 24 V DC/1A (on the peripheral module)
- TTY or RS 485 interface, optional RS 232
- Integration in the short circuit and open circuit resistant essernet network with up to 31 fire detection panels depends on transmission rate
- Connection to graphical supervisor WINMAG via serial essernet interface (SEI)

- Operating panel with alphanumerical display
- Large LCD display with 8 rows x 40 characters
- Event memory for up to 10,000 events
- All System 8000 micromodules are compatible
- Printer interface for internal printer
- Two batteries with monitoring circuit
- Monitored input for external power supply unit

Additional features for powered loop

- Max. 2 analog powered loop modules (System supports up to 254 digital loop addresses in total)
- BUS powered, synchronously controlled, acoustic alarm signaling devices as per DIN EN 54-3 with alarm tone as per DIN 33404
- Up to 48 powered loop base sounders (series 9200) per loop
- Up to 32 powered loop IQ8Alarm per loop
- Up to 48 IQ8Quad with alarm device per loop

Approval: VdS, CNBOP, BOSEC
 VdS system certificate: S 294050

The IQ8Control C is an efficient fire alarm control panel for the property supervision of small to mid-sized objects facilitates simultaneous detection, control and alarm signaling both on the analog ring as well as on the spur. Within the multi-functional IQ8Control C panel, the operation type (powered-loop or non-powered-loop) can be selected via a jumper located on the control panel power supply unit. Depending on which loop operation type has been selected, the corresponding loop module/modules are required.

Technical Data

Rated voltage	230 V AC
Rated frequency	50 ... 60 Hz
Rated current	0.35 A (standard); 0.7 A (powered loop)
Quiescent current	approx. 215 mA (basic configuration without operating unit) approx. 230 mA (basic configuration with operating unit)
Current consumption for ext. devices	max. 2 A @ 12 V DC
Battery capacity	2 x 12 Ah, 2 x 26 Ah in extension housing
Ambient temperature	-5 °C ... 45 °C
Storage temperature	-5 °C ... 50 °C
Air humidity	< 95 % (non-condensing)
Type of protection	IP30
Housing	ABS, 10 % glass fiber reinforced, V - 0
Color	gray similar to Pantone 538
Weight	approx. 6.5 kg
Dimensions	W: 450 mm H: 320 mm D: 185 mm
Declaration of Performance	DoP-20827130701

- The IQ8Control fire detection panels are fully compatible with FACP 8000 panels within essernet applications
 - FACP 8000 micromodules are also compatible with IQ8Control devices
 - Housing form and color comply with the FACP 8000 generation
 - The IQ8Control panels can only be programmed with the tools 8000 software solution (Part No. 789861) and the field bus interface (Part No. 789862.10) or directly via USB with the RS-232 interface (Part No. 769828), with the field bus interface or the RS232 interface.

Combined with Part No. 808619.10 FSA transponder, the control panel can be used to control automatic door arrester systems in compliance with the German Institute for Construction Engineering (DIBt: Deutsches Institut für Bautechnik).

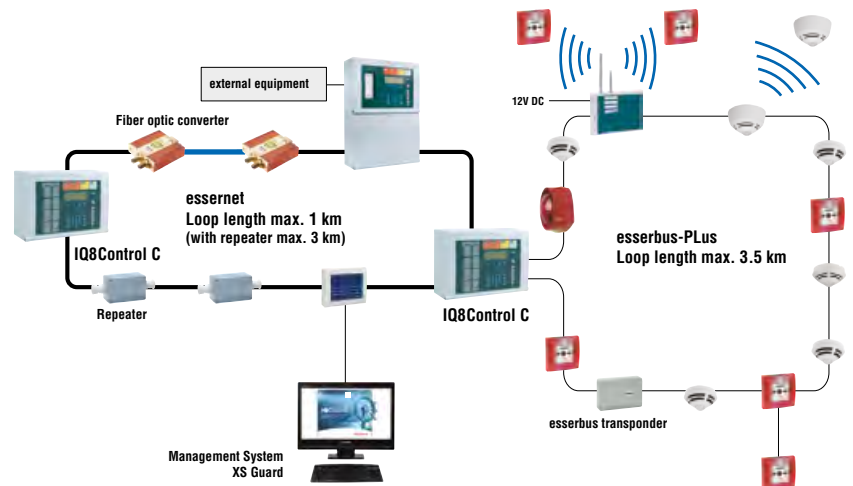

Connection example

Order Diagram FACP IQ8Control C/Intelligent Addressable

1

1. Choice of the housing type



IQ8ControlC standard housing 808003

IQ8ControlC for 19" cabinet 808139

Slot for one micromodule as standard

2. Choice of the control panel modules
(only 1 module at a time)

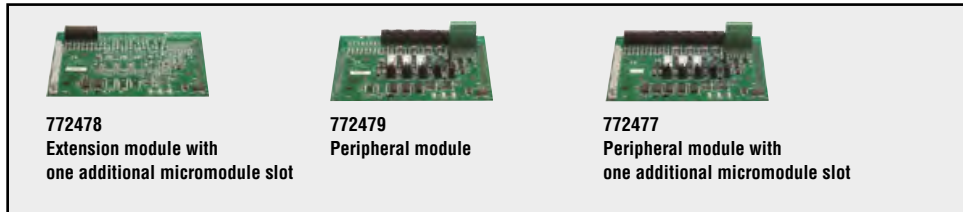

772478

Extension module with one additional micromodule slot

772479

Peripheral module

772477

Peripheral module with one additional micromodule slot

3. Choice of the micromodules



804382.D0

Analog loop module powered loop

784382.D0

Analog loop module

771670

Master box interface module

784840.10

essernet module 62.5kBd

787531

3-relay module

784842

RS 232/TTY serial interface module

784385

Master box interface module

784841.10

essernet module 500kBd

787532

3-relay common fault module

787530

4-relay module

4. Choice of the operating front*
language codes available:

- 01 Germany
- 02 England
- 03 Italy
- 04 Portugal
- 05 Poland
- 06 Spain
- 07 Austria
- 08 Netherlands
- 09 Czech Republic
- 10 Russia
- 11 Hungary
- 12 Denmark
- 13 Sweden
- 14 Croatia
- 15 France
- 16 Slovakia
- 17 Switzerland / French
- 18 Romania
- 19 Slovenia
- 20 Turkey
- 21 Greece
- 22 Belgium / Flemish
- 23 Belgium / Walloon
- 25 Arabic / English
- 27 Serbian

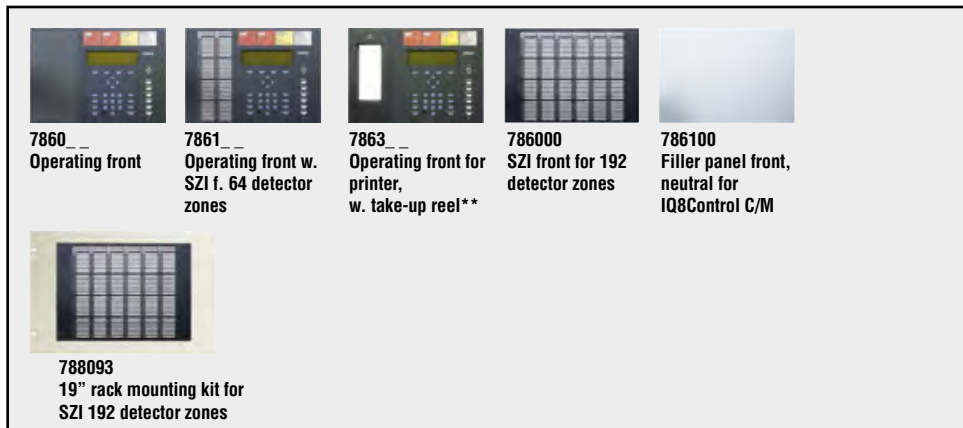

7860

Operating front

7861

Operating front w. SZI f. 64 detector zones

7863

Operating front for printer, w. take-up reel**

786000

SZI front for 192 detector zones

786100

Filler panel front, neutral for IQ8Control C/M



788093

19" rack mounting kit for SZI 192 detector zones

All operating fronts, except SZI 192 detector zones are suitable for both housing types

*Space for only 1 battery **Requires an additional extension housing

5. Choice of an extension housing
(optional)



789300

Battery extension housing

789302

Extension housing for SZI 192 detector zones

789301

Extension housing for batteries and SZI 192 detector zones

FACP IQ8Control C Standard and for 19" Racks

808003**FACP IQ8Control C**

Basic design.



The operating front must be ordered separately and is not included in the price.



Housing with standard rear panel and front frame for operating panel fronts, interface board, power supply module, system software.

808139**FACP IQ8Control C for 19" rack**

Same as 808003, but 19" version (7 HU) for rack installation.



The operating front must be ordered separately and is not included in the price.



FACP 808003 IQ8Control C, including 19" installation frame and flat cable for 19" installation.

Accessories for FACP IQ8Control C

789300

Battery extension housing



Extension housing for additional batteries.

Technical Data

Ambient temperature	-5 °C ... 45 °C
Storage temperature	-10 °C ... 50 °C
Type of protection	IP 30
Housing	ABS, 10% glass fiber reinforced, V - 0
Weight	approx. 5 kg (without battery)
Dimensions	W: 450 mm H: 320 mm D: 185 mm

 Batteries are not included and must be ordered separately.

 Housing complete with battery rear panel, connecting cable for battery, mounting positions for two 12 V / 26 Ah batteries. Neutral front and material for attaching to the existing panel housing, battery connecting cables, 800 mm.

Assembling the housing parts

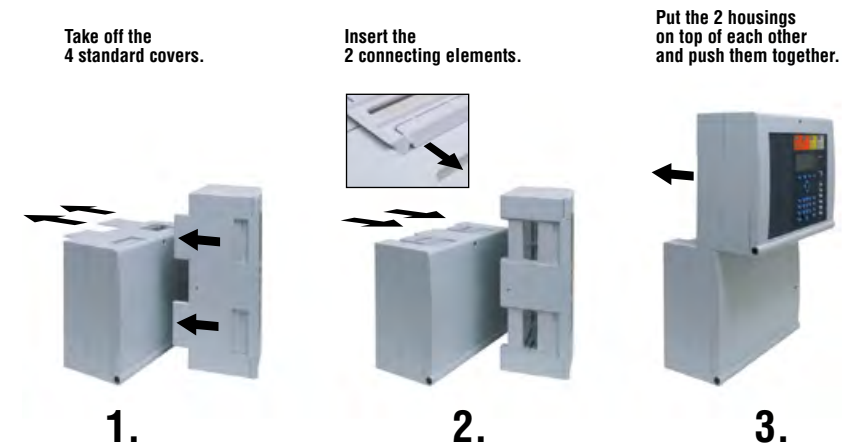

Connection between the central housing and the extension housing

789301

Extension housing for batteries with 192 detector zones



Technical Data

Quiescent current	approx. 5 mA
Current consumption	1.5 mA when LED activated
Ambient temperature	-5 °C ... 45 °C
Type of protection	IP 30
Housing	ABS, 10% glass fiber reinforced, V - 0
Color	gray similar to Pantone 538
Weight	approx. 5.5 kg (without battery)
Dimensions	W: 450 mm H: 320 mm D: 185 mm

 This housing cannot be used if an operating module front with single zone indicator unit for 64 zones is already fitted. Batteries are not included and must be ordered separately. A single zone indicator unit can only be used in connection with an operating module front.

 Housing complete with battery rear panel, connecting cable for batteries, mounting positions for two 12 V / 26 Ah batteries, single zone indicator front for 192 detector zones and material for attaching to the existing panel housing.

789302

Extension housing for SZI 192 detector zones IQ8Control



The housing can be used to mount additional modules, e.g. an esserbus transponder.

Technical Data

Quiescent current	approx. 5 mA
Current consumption	1.5 mA when LED activated
Ambient temperature	-5 °C ... 45 °C
Type of protection	IP 30
Housing	ABS, 10% glass fiber reinforced, V - 0
Color	gray similar to Pantone 538
Weight	approx. 5 kg
Dimensions	W: 450 mm H: 320 mm D: 185 mm



This housing cannot be used if an operating module front with single zone indicator unit for 64 zones is already fitted. A SZI unit can only be used in combination with an operating module front.



Housing complete with standard rear panel, single zone indicator front for 192 detector zones and material for attaching to the existing panel housing.

IQ8Control M/Intelligent Addressable

Features

- Max. five micromodules, with peripheral module Part No. 772477, up to five esserbus analog loop modules (system supports up to 635 digital loop addresses in total)
- Max. seven micromodules, with extension module Part No. 772476, up to seven esserbus analog loop modules (system supports up to 889 digital loop addresses in total)
- Short circuit and open circuit tolerant loop operation
- Loop installation with I-Y(ST)Y 0.8 mm cable for a maximum length of 3.5 km
- Up to 127 esserbus devices (fire detectors and/or manual call points)/detector zones per loop
- Up to 32 esserbus transponders/wireless transponders per loop
- Up to 127 IQ8/FCT transponders per loop
- Operation types TM and PM as per DIN VDE 0833 - 2 to avoid unwanted alarms being triggered
- Fire brigade operating panel and transmission interface on the peripheral module
- Three common relays, freely programmable, monitored, floating for up to 30 V DC/1A (on the peripheral module)
- TTY or RS 485 or RS 232 interface
- Integration in the short circuit and open circuit resistant essernet network with up to 31 fire detection panels depends on transmission rate
- Connection to graphical supervisor WINMAG via serial essernet interface (SEI)
- Operating panel with alphanumerical display
- Large LCD display with 8 rows x 40 characters
- Event memory for up to 10,000 events
- All Systems 8000 micromodules are compatible
- Printer interface for internal printer
- Two batteries with monitoring circuit
- Monitored input for external power supply unit

Additional features for powered loop

- Max. 6 analog powered loops and expandable up to 127 loop devices (per loop) in mixed mode / loop powered and non-loop powered (system supports up to 762 digital loop addresses in total)
- esserbus PPlus (Powered Loop) supplied, synchronously controlled, acoustic alarm signaling devices as per DIN EN 54 - 3 with alarm tone as per DIN 33404
- Up to 48 powered loop base sounders (series 9200) per loop
- Up to 32 powered loop IQ8Alarm per loop
- Up to 48 IQ8Quad with alarm device per loop

Approval: VdS, CNBOP, BOSEC
VdS system certificate: S 294050

The IQ8Control M as an efficient fire alarm control panel (FACP) for the property supervision of mid-sized to large objects, facilitates simultaneous detection, control and alarm signaling both on the analog ring as well as on the spur. The loop operation type of the panel (powered-loop or non-powered-loop) can be selected via a jumper located on the power supply card. Depending on which loop operation type has been selected, the corresponding analog module/modules should be used.

Technical Data

Rated voltage	230 V AC
Rated frequency	50 ... 60 Hz
Rated current	0.35 A (standard); 0.7 A (powered loop)
Output voltage	12 V DC
Quiescent current	approx. 215 mA (basic configuration without operating unit) approx. 230 mA (basic configuration with operating unit)
Current consumption for ext. devices	max. 2 A @ 12 V DC
Battery capacity	max. 2 x 12 V/26 Ah
Ambient temperature	-5 °C ... 45 °C
Storage temperature	-10 °C ... 50 °C
Air humidity	< 95 % (non-condensing)
Type of protection	IP30
Housing	ABS, 10 % glass fiber reinforced, V - 0
Color	gray similar to Pantone 538
Weight	approx. 11.5 kg
Dimensions	W: 450 mm H: 640 mm D: 185 mm
Declaration of Performance	DoP-20827130701

- The IQ8Control fire detection panels are fully compatible with FACP 8000 panels within essernet applications
- FACP 8000 micromodules are also compatible with IQ8Control devices
- Housing form and color comply with the FACP 8000 generation
- The IQ8Control panels can only be programmed with the tools 8000 software solution (Part No. 789861) and the field bus interface (Part No. 789862.10) or directly via USB with the RS-232 interface (Part No. 769828), with the field bus interface or the RS232 interface.

Combined with 808619.10 FSA transponders, the control panel can be used to control automatic door arrester systems in compliance with the German Institute for Construction Engineering (DIBt: Deutsches Institut für Bautechnik).

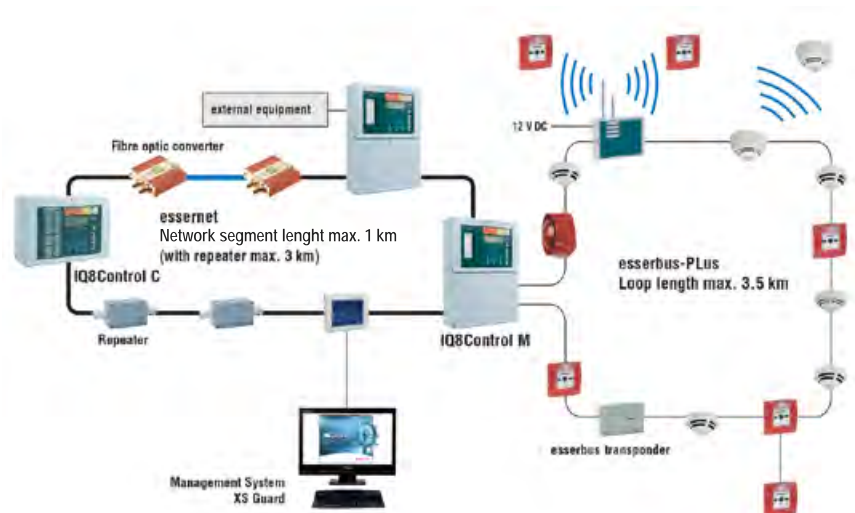

Application example

Order Diagram FACP IQ8Control M/Intelligent Addressable

- 1. Choice of the housing type**
- 2. Choice of the control panel modules**
 2 Extension modules
 or
 1 Extension module +
 1 Peripheral module
- 3. Choice of the micromodules**
- 4. Choice of the operating front***
 language codes available:
 01 Germany
 02 England
 03 Italy
 04 Portugal
 05 Poland
 06 Spain
 07 Austria
 08 Netherlands
 09 Czech Republic
 10 Russia
 11 Hungary
 12 Denmark
 13 Sweden
 14 Croatia
 15 France
 16 Slovakia
 17 Switzerland / French
 18 Romania
 19 Slovenia
 20 Turkey
 21 Greece
 22 Belgium / Flemish
 23 Belgium / Walloon
 25 Arabic / English
 27 Serbian
- 5. Choice of an extension housing (optional)**



Slot for one micromodule as standard

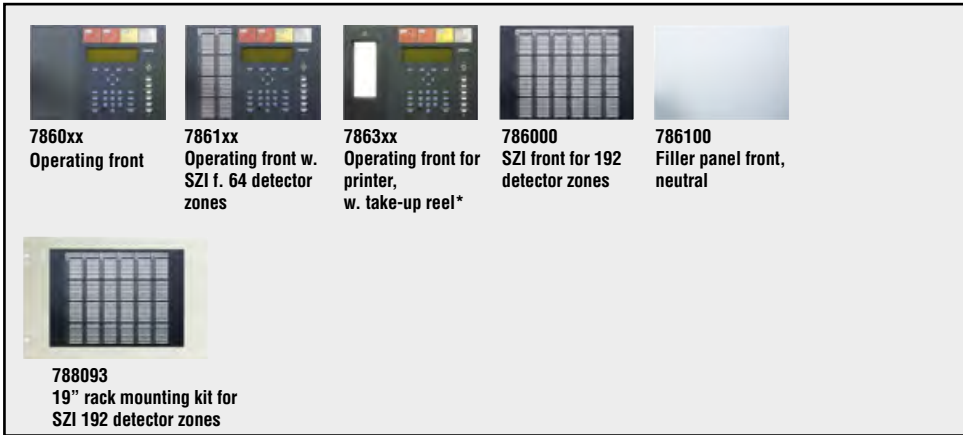
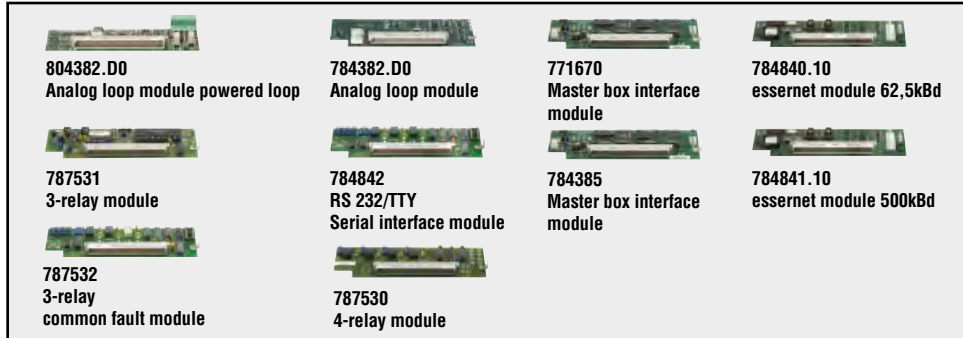
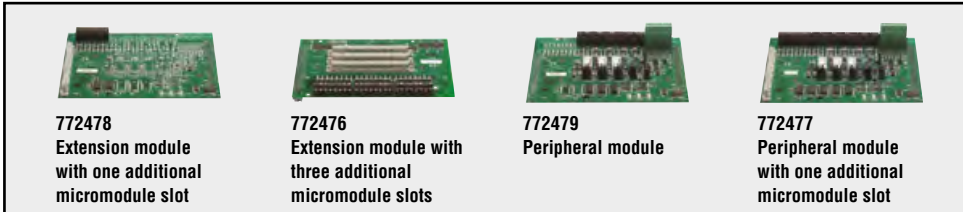

All operating fronts, except SZI 192 detector zones are suitable for both housing types

*Requires an additional extension housing





FACP IQ8Control M Standard and for 19" Racks

808004



FACP IQ8Control M

Basic design.



-  The operating front must be ordered separately and is not included in the price.
-  Housing with rear panel and front frame for operating panel fronts, neutral front, interface board, power supply module and system software.

808219



FACP IQ8Control M for 19" rack

As 808004 but 19" version (7 HU) for rack installation.

-  The operating front must be ordered separately and is not included in the price.
-  FACP IQ8Control M 808004, including 19" mounting frame and flat cable for 19" installation.

789303



Extension housing

The standard extension housing can be used to mount additional modules, e.g. esserbus transponders.

Technical Data

Ambient temperature	-5 °C ... 45 °C
Storage temperature	-10 °C ... 50 °C
Type of protection	IP30
Housing	ABS plastic, 10% glass fiber reinforced, V - 0
Color	gray similar to Pantone 538
Weight	approx. 5 kg
Dimensions	W: 450 mm H: 320 mm D: 185 mm

Features

- For the installation of up to 6 transponders and FO converters with installation kit 788650.

-  Housing complete with standard rear panel, neutral front and material for attaching to the existing control panel housing.

Assembling the housing parts

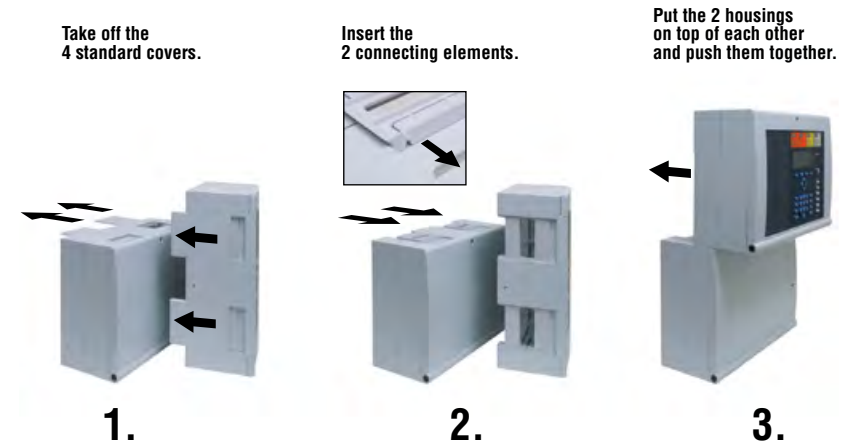

Connection between the central housing and the extension housing

Operating Fronts for IQ8Control C/M

Features

- alphanumerical display
- Large LCD display with 8 rows x 40 characters

ESSER - front (Part No. 7860XX, 7861XX and 7863XX) is also available with the respective country specification - except the special versions. When ordering, please fill in the last two digits with the specific language code.

(Not all variants are available in all languages. Please contact your sales representative for details)

Example:

The German version of the standard operating front C/M would have the Part No. 7860-01.

For the Dutch version, the number would have to be changed to Part No. 7860-08.

Specific language code:

01 German	14 Croatian
02 English	15 French (France)
03 Italian	16 Slovakian
04 Portuguese	17 French (Switzerland)
05 Polish	18 Romanian
06 Spanish	19 Slovenian
07 German (Austria)	20 Turkish
08 Dutch	21 Greek
09 Czech	22 Flemish (Belgium/Dutch)
10 Russian	23 Walloon (Belgium/French)
11 Hungarian	25 Arabic/English
12 Danish	27 Serbian
13 Swedish	52 Chinese
13 Swedish	53 Chinese with country functionality

786002

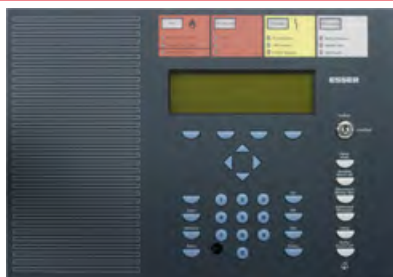

Operating front, English

786102



Operating front with single zone indication 64, English

Technical Data

Current consumption

single zone indication: per activated LED
1.5mA

786302



Operating front for printer and w. take-up reel, English



The printer kit with paper take-up reel (Part No. 784892) must be ordered separately.

786000

SZI front for 192 detector zones



Technical Data

Quiescent current	approx. 5 mA
Current consumption	single zone indication: per actuated LED 1.5mA

 Including insertable foils with country-specific version.

786100

Filler panel front, neutral



788093

19" rack mounting kit for SZI 192 detector zones



7 HU for upright cabinet mounting.

Technical Data

Quiescent current	approx. 5 mA
Current consumption	1.5 mA per actuated LED

 772445 Mounting frame
786000 SZI front for 192 detector zones, including insertable foils with country-specific version

1
2
3
4
5
6
7
8
9
10
11
12
13
14

Micromodules for IQ8Control C/M

784382.D0

Analog loop module



Single loop circuit module for up to 127 series 9200/IQ8 Quad intelligent fire detectors or bus devices, divisible into 127 zones.

Technical Data

Quiescent current approx. 25 mA

804382.D0

Analog loop module powered loop (PL)



Single loop circuit module for up to 127 bus devices, and esserbus-PLus (powered loop) devices according to the load factor. Series 9200/IQ8 Quad intelligent fire detectors and esserbus transponders (Part No. 80xxxx) or addressable sounders and powered loop base sounders.

Technical Data

Quiescent current approx. 25 mA

 Powered loop compatible only with IQ8Control and FlexES.

784842

Master box interface module, 8007/8008, ESSER



Serial interface module with optional RS 232 or TTY type, for operating external devices such as external printers, modems for remote diagnosis.

Technical Data

Quiescent current approx. 35 mA (RS 232)
approx. 55 mA (TTY)

787531

3-relay module



3-relay module with output functions which can be programmed either as NC or NO contacts, 3 x latching "monitored" relay outputs.

Technical Data

Quiescent current approx. 5 mA
Contact load relay max. 30 V DC/1 A

787532

3-relay common fault module



3-relay module with pre-set functions such as common fault, 2 x freely programmable monitored relay outputs.

Technical Data

Quiescent current approx. 15 mA
Contact load relay max. 30 V DC/1 A

Accessories

736235



Printer paper for printer 736233/736234/784892, IQ8Control C/M

Printer paper for (Part No. 736233) printer without paper take-up reel and for (Part No. 736234) printer with take-up reel.

Technical Data

Dimensions L: 2500 mm W: 58 mm

772445



Mounting frame 19" IQ8Control C/M

 Mounting frame with 6 HU for mounting of operating front.

743212



Spare key 1D009 for FACP

For upright cabinets 769163 and 769164.

 Two keys.

743245



Lever lock - type 17 for key no. 801

To lock and unlock the HMI of fire alarm panels 2001, IQ8Control C/M, 8000 M/C, 8007, 8008.

 Two keys and one cylinder lock.

769914



Spare key 801 for FACP

To lock and unlock the HMI of fire alarm panels 2001, IQ8Control C/M, 8000 M/C, 8007, 8008.

 Two keys.

743248



Lever lock - type for key no. 901

To lock and unlock the housing frame of fire alarm panels IQ8Control C/M, 8000 M/C and FlexES.

 Two keys and one cylinder lock.

769915

Spare key 901 for FACP



For fire alarm panels 2001, IQ8Control C/M, 8000 C/M, 8008 for printer and housing.

 Two keys.

744030

Dummy cover 19", 2 HU



For covering free installation space in upright cabinets and wallmount cabinets, 2 HU.

Technical Data

Material	sheet steel
Color	gray similar to Pantone 538

 One height unit (HU) covers 44.45 mm.

744027

Dummy cover 19", 3 HU



Same as 744030, but 3 HU.

Technical Data

Color	gray similar to Pantone 538
-------	-----------------------------

744028

Dummy cover 19", 5 HU

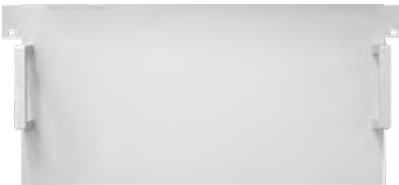

Same as 744030, but 5 HU.

744029

Dummy cover 19", 9 HU



Same as 744030, but 9 HU.

1
2
3
4
5
6
7
8
9
10
11
12
13
14

Maintenance and Test Equipment

789861



Programming software tools 8000

Convenient Windows programming software CD for programming the fire alarm panels belonging to series 8000 C/M, 8008, IQ8Control, FlexES Control, Gateway and extended supplementary text in ¼ VGA display.

Available Languages:

Czech, Danish, English, French, German, Hungarian, Italian, Slovakian, Spanish, Polish, Portuguese, Romanian and Russian.

Features

One software for all panels:

- Start-up
- Programming
- Loop diagnosis
- Maintenance software

For programming, the (Part No. 789862.10) field bus interface is required.



- FACP 8000 C/M, FACP 8008, IQ8Control C/M, FlexES Control or ECP 8010 as of software version V2.20
- PC/Notebook as of Windows XP, Windows 7, Windows 8
- Recommended configuration: 512 MB RAM, 500 MHz CPU
- This software is also used for the LCD panels 7851xx

789860.10



Starter kit equipment PPlus with programming software tools 8000

Complete package for programming the FACP 8007, 8000 C/M, 8008, Gateway, ABIGA IQ8Control and FlexES Control via PC or Notebook.



The field bus interface is used as a programming interface between the FACP and the PC/notebook.

Furthermore, the field bus interface facilitates the direct connection of a ring bus to the convenient monitoring of a finished installation and the elimination of possible cabling mistakes.



- 789861 Programming software for System 8000 and IQ8Control
- 789862.10 Field bus and control panel interface PPlus
- 789863 USB cable
- 789864 Serial connecting cable

Accessories

BME2Z002 Switched-mode power supply with cylindrical plug

789866 Programming cable for extinguishing panel 8010

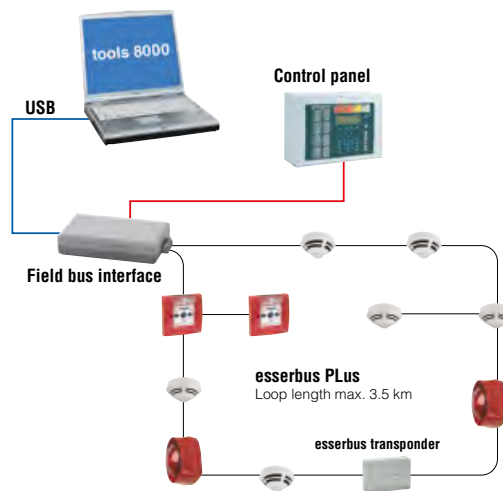

Application example

789862.10



Field bus interface PPlus

Interface for the programming of the FACP 8007, 8000 C/M, 8008, gateway, ABIGA and IQ8Control or for the direct field-side connection of a single installed analog loop. With the optional switched-mode power supply (Part No. BME2Z002), bus-supplied alarm signaling equipment can be tested independently from the control panel via the direct connection to the field bus interface (Part No. 789862.10).

Technical Data

Ambient temperature	5 °C ... 45 °C
Storage temperature	0 °C ... 50 °C
Type of protection	IP 40
Housing	plastic, PS (Polystyrene)
Color	white, similar to RAL 9010 / gray, similar to RAL 7035
Weight	approx. 300 g
Dimensions	W: 68 mm H: 30 mm D: 135 mm

Connecting cables (Part No. 789863 and 789864) are not included in delivery.

One interface and two 6-pin plugs.

Accessories

BME2Z002 Switched-mode power supply with cylindrical plug

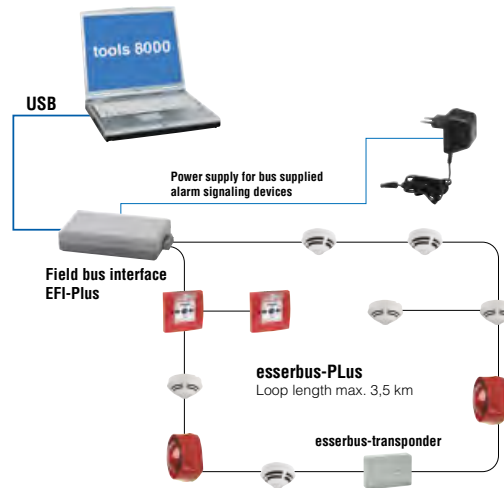

Application example

789863



USB cable A/B for 789862.10 field bus and panel interface

For connecting service PC/laptop with the tools 8000 field bus and panel interface.

Technical Data

Cable length	1.8 m
--------------	-------

789864



Serial connecting cable for 789862.10

For connecting the field bus interface to panels 8007, 8000 C/M, 8008, Gateway, ABIGA and IQ8Control. With 4-pin special plug for the control panel.

Technical Data

Cable length	1.9 m
--------------	-------

BME2Z002



Switched-mode power supply with cylindrical plug

Technical Data

Output voltage	12 V DC
Output current	1 A

789866



Programming cable for ECP 8010

Connecting lead for programming the extinguishing control panel 8010 to 789862.10 interface.

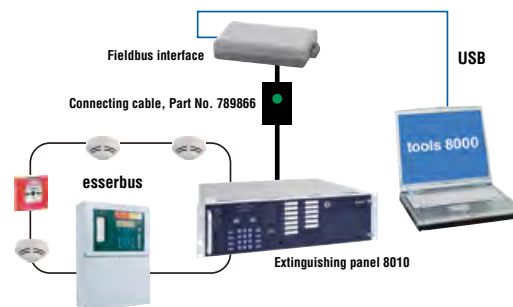

Extinguishing System 8010 - Wall Mounting



Features

- 1 Extinguishing area for max. 1.600 m² acc. to VdS
- 8 detector zones for up to 30 Series 9200 and IQ8Quad automatic detectors each (for two-detector dependency up to 25 detectors)
- 1 zone for manual alarm
- 1 zone for emergency stop
- 1 zone for post flooding
- 1 zone for extinguishing system fault
- 1 zone for blocking extinguishing system
- 1 control input for buzzer OFF
- 1 control input for control panel reset
- 8 relays, monitored or floating 30V DC/2A
- 3 relays, floating 30V DC/2A
- 2 mains voltage relays, floating 230V AC/2A
- All outputs are provided with fuses

Approval: VdS

Addressable control device with integrated fire detection module for an extinguishing area in accordance with VdS 2496 and EN 12094-1. The extinguishing panel 8010 is an electronic control device for extinguishing systems with integrated fire detection module, compatible with Series 9200 and IQ8Quad detectors. It is additionally provided with respective detection zones for manual alarm, post flooding and emergency stop as well as two zones for extinguishing system fault. Complex control functions can be realised by using the 13 control groups (relays). Up to 8 extinguishing areas on the esserbus of the fire detection system communication transponders (optional). Respectively max. 16 communication transponders per FACP 8000 C/M or IQ8Control 8000 or IQ8Control can be networked via the 808615.

Technical Data

Rated voltage	230 V AC
Rated frequency	50 ... 60 Hz
Quiescent current	approx. 100 mA
Rated current	0.7 A
Battery capacity	2 x 12 V/26 Ah
Ambient temperature	-5 °C ... 45 °C
Storage temperature	-10 °C ... 50 °C
Type of protection	IP 30
Housing	sheet steel approx. 1.25 mm
Color	gray (similar to RAL 7035), blue (similar to RAL 5003)
Weight	approx. 18.3 kg (without battery)
Dimensions	W: 488 mm H: 625 mm D: 210 mm
CE certificate	0786-CPD-20223

 The free programming software can be downloaded from our website (downloads section).

Accessories

Indicating and operating unit 788400 (required for stand alone operation), 788615 esserbus communication transponder, control zone indicator and 788016 alarm counter.

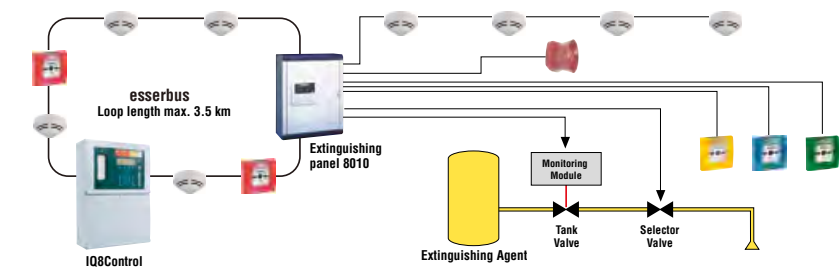

Application example

788012.40



Extinguishing panel 8010, Series 4, w/o operating unit

Corresponding indication and operating panel available in different languages, which can be found in "Options for Extinguishing Control Panels 8010 Wall Mounting".

788013.40

Extinguishing panel 8010, Series 4, with operating unit, German

Same as 788012.40, but with operating unit (Part No. 788400).

788013.40.RU

Extinguishing panel 8010, Series 4, with operating unit, Russian

Same as 788013.40, but Russian version.

Extinguishing Control Panel 8010 - Rack Mounting, 3HU

Features

- 8 detector zones for up to 30 series 9200 or IQ8Quad automatic fire detectors per detector zone (max. 25 detectors in two-detector dependency)
 - 1 detector zone manual alarm
 - 1 detector zone emergency stop
 - 1 detector zone post flooding
 - 1 detector zone blocked extinguishing system
 - 1 control input buzzer off
 - 1 control input reset control panel
 - 8 monitorable relays 30 V DC /2A
 - 3 floating relays 30 V DC /2A
 - 2 relays for mains voltage 230 V (connection at the back)
 - Each output is protected by fuses
 - Electronically controlled ventilation fan
- Operating unit:**
- 13 LED-indication with inscription fields for indicating activated outputs
 - Mechanical alarm counter
 - LED display to indicate the detector zone status
 - LED collective display
 - Keypad can be intuitively handled
 - Key operated switch for keypad activation
 - Emergency current supply 2 batteries 12 V/12 Ah (not supplied as standard)

Addressable EN 12094-1 extinguishing panel for extinguishing zone control in compliance with VdS 2496, with integrated fire detection unit and optional convenient operating and indicating panel.

The slide-in concept enables space-saving, ergonomic integration into a 19" housing for installation heights of only 3 height units (13.34 cm). Peripherals are connected at the back of the housing via plug-in cable connections to accessible connection terminals, allowing convenient installation within the housing before the insert is integrated. With the communication transponder (Part No. 808615), a maximum of eight extinguishing control panels can be networked on one esserbus or powered loop in fire alarm systems FACP 8000, Q8Control or FlexES Control. Using the programming interface plugged to the front, the extinguishing panel settings can be adjusted to the specific requirements and information can be transferred for visualizing the master fire alarm system via the loop.

Technical Data

Rated voltage	230 V AC
Rated frequency	50 ... 60 Hz
Rated current	0.7 A
Quiescent current	approx. 100 mA
Battery capacity	2 x 12 V DC/12 Ah
Ambient temperature	-5 °C ... 45 °C
Storage temperature	-10 °C ... 50 °C
Air humidity	< 95 % (non-condensing)
Type of protection	IP 30
Housing	sheet steel
Dimensions	W: 483 mm H: 132 mm D: 403 mm (without grip)
Declaration of Performance	DoP-20223130701



The use of heavy duty rails from the respective cabinet manufacturer is recommended for installation in 19" upright cabinets.

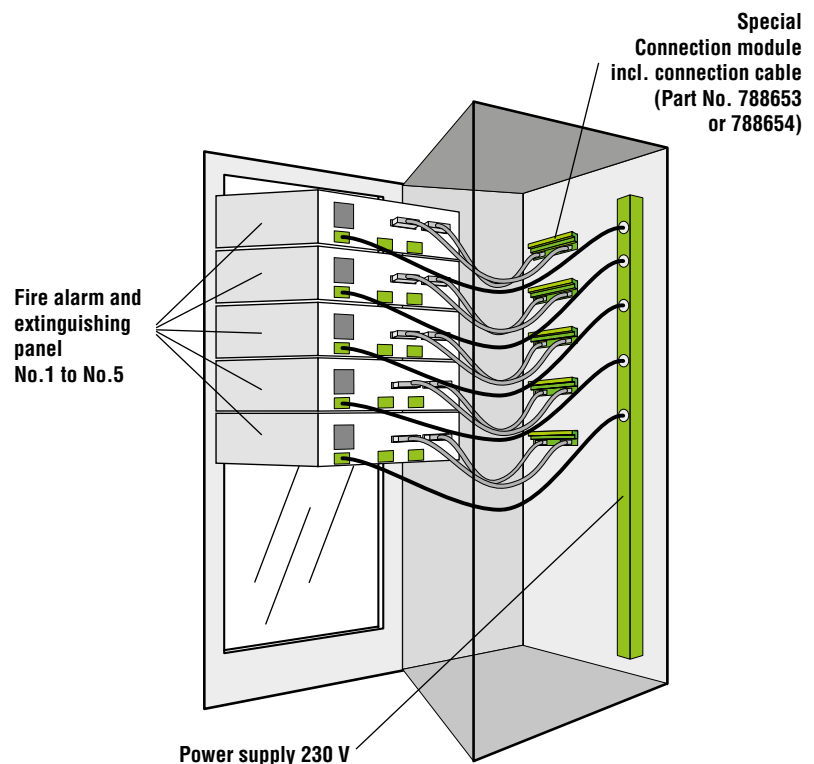

Installation of multiple extinguishing panels in one upright cabinet

788014.40

Extinguishing control panel, Series 4, German**Approval: VdS**

Extinguishing panel as per 12094 for extinguishing zone control in compliance with VdS 2496, with integrated fire detection unit and optional convenient operating and indicating panel. The slide-in concept enables space-saving, ergonomic integration into a 19-inch housing for installation heights of only 3 height units (13.35 cm). Peripherals are connected at the back of the housing via plug-in cable connections to accessible connection terminals, allowing convenient installation within the housing before the insert is integrated. With the communication transponder (Part No. 808615), a maximum of eight extinguishing control panels can be networked on one esserbus or powered loop in Fire Alarm Systems FACP 8000, IQ8Control or FlexES Control. Via the programming interface plugged to the front, the extinguishing panel settings can be adjusted to the specific requirements and information can be transferred for visualising to the master fire alarm system via the loop.

Accessories

788653 Terminal card for panel 8010 in 19" technology (3 HU), 1 m

788654 Terminal card for panel 8010 in 19" technology (3 HU), 2 m

788014.40.GB

Extinguishing control panel, Series 4, English

As 788014.40, but English version.

788014.40.PL

Extinguishing control panel 8010 Series 4 with operating unit, Polish

As 788014.40, but Polish version.

788014.40.CZ

Extinguishing control panel 8010 Series 4 with operating unit, Czech

As 788014.40, but Czech version.

788014.40.RO

Extinguishing control panel 8010 Series 4 with operating unit, Romanian

As 788014.40, but Romanian version.

788014.40.RU

Extinguishing control panel 8010 Series 4 with operating unit, Russian

As 788014.40, but Russian version.

Accessories for Extinguishing Control Panels 8010 in 19" Racks

788653

Terminal card for panel 8010 in 19" rack, 1 m



Length of plug-in connection cables: 1 m



2 x 50-pin connection cable 1m D-Sub50

1 x Terminal card for top hat rail or C-rail mounting with D-Sub pin connectors

1 x Terminal card for top hat rail or C-rail mounting with D-Sub multi-point connectors

788654

Terminal card for panel 8010 in 19" rack, 2 m

As 788653, but plug-in connection cable with 2 m length.

788400

Indicating and operating panel for ECP 8010, German



Integrated detector zone indication in German. Can be set to show status indication for control outputs. LED for relevant extinguishing system function indication.

788401

Indicating and operating panel for ECP 8010, English

Same as 788400, but English.

788402

Indicating and operating panel for ECP 8010, Polish

As 788400, but Polish.

788404

Indicating and operating panel for ECP 8010, Czech

As 788400 but Czech.

788406

Indicating and operating panel for ECP 8010, Romanian

As 788400 but Romanian.

788016

Option control group indication and alarm counter for ECP 8010, German



Foil with German description

788023.10

Multiple-sector interface in housing



Approval: VdS

For the formation of multiple-sector control, up to four extinguishing panels 8010 can be networked via a multiple-sector interfaces. The cascading of a max. of 3 multiple-sector interface is possible for multi-sector control of a max. of 10 extinguishing panels 8010.

Technical Data

Declaration of Performance

DoP-21170130701

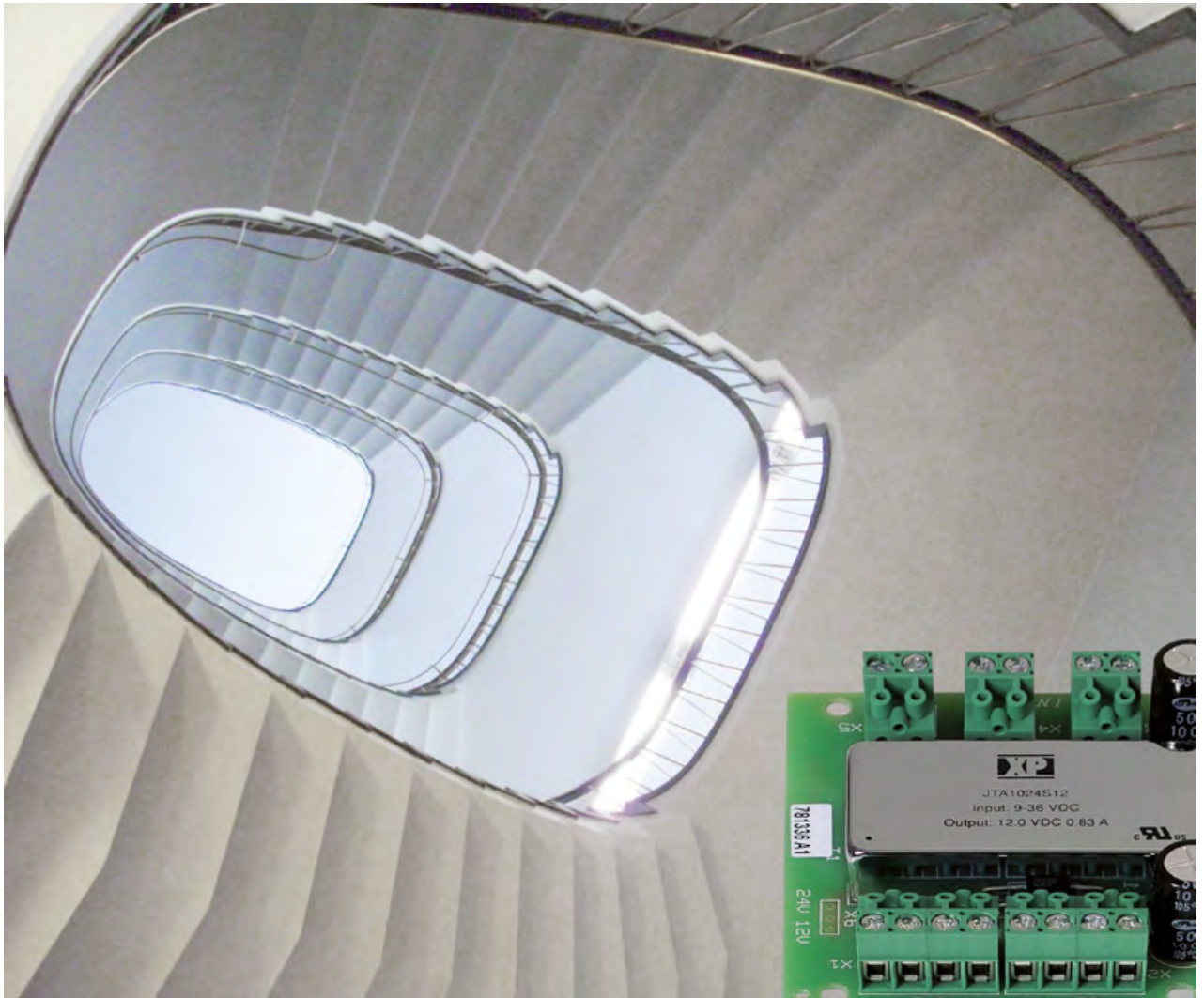

Power Supplies

Power Supply Units	30-32
Voltage Converters	33
Batteries (Rechargeable)	34
Accessories	34

Power Supply - Housing Version



Approval: VdS, CNBOP

The power supply ZSP135-DR is dedicated to work in fire detection and building automation systems. It is a source of guaranteed 24V voltage. It is manufactured as a wall box with a lock. It has a space inside to mount two batteries. The controller protects the internal battery bank against too low discharge by means of the built-in disconnect device. The power supply complies with the norm EN 54 and EN 12101-10.

- Application:- components of fire alarm systems
- actuators of smoke extraction systems and fire and smoke dampers
 - fire alarm detector and sounders
 - devices of industrial automation

Features

- light indication of the state of the power supply
- floating mode with temperature compensation
- equalize charging of the battery with the charging current limitation
- detection of low and high voltage of the battery
- detection of a battery circuit break
- electronic low voltage disconnect of the battery
- monitoring of output fuses
- continuous testing of the rectifier's operation
- monitoring of the internal temperature
- visual and remote indication of alarm

Technical Data

Rated voltage	230 V AC
Output voltage	24 V DC
Efficiency	> 80 %
Cooling	Convection
Ambient temperature	-25 °C ... 55 °C
Type of protection	IP43

960000.10.GB

External power supply 2 A / 24 V DC 17Ah EN 54-4

Batteries for power supplies ZSP135-DR should be ordered separately.

Technical Data

Output current	max.2 A
Rated Output Current	1 A
Battery capacity	max. 17 Ah
Weight	approx. 18 kg (incl. batteries)
Dimensions	W: 390 mm H: 350 mm D: 90 mm

960001.10.GB

External power supply 3 A / 24 V DC 17Ah EN54-4

Batteries for power supplies ZSP135-DR should be ordered separately.

Technical Data

Output current	max.3 A
Rated Output Current	2 A
Battery capacity	max. 17 Ah
Weight	approx. 18 kg (incl. batteries)
Dimensions	W: 390 mm H: 350 mm D: 90 mm

960002.10.GB

External power supply 3 A / 24 V DC 28Ah EN 54-4

Batteries for power supplies ZSP135-DR should be ordered separately.

Technical Data

Output current	max.3 A
Rated Output Current	1.5 A
Battery capacity	max. 28 Ah
Weight	approx. 28.3 kg (incl. batteries)
Dimensions	W: 390 mm H: 350 mm D: 140 mm

960003.10.GB

External power supply 5 A / 24 V DC 17Ah EN 54-4

Batteries for power supplies ZSP135-DR should be ordered separately.

Technical Data

Output current	max. 5 A
Rated Output Current	4 A
Battery capacity	max. 17 Ah
Weight	approx. 18 kg (incl. batteries)
Dimensions	W: 390 mm H: 350 mm D: 90 mm

960004.10.GB

External power supply 5 A / 24 V DC 28Ah EN 54-4

Batteries for power supplies ZSP135-DR should be ordered separately.

Technical Data

Output current	max. 5 A
Rated Output Current	3.5 A
Battery capacity	max. 28 Ah
Weight	approx. 28.3 kg (incl. batteries)
Dimensions	W: 390 mm H: 350 mm D: 140 mm

960005.10.GB

External power supply 5 A / 24 V DC 40Ah EN 54-4

Batteries for power supplies ZSP135-DR should be ordered separately.

Technical Data

Output current	max. 5 A
Rated Output Current	3 A
Battery capacity	max. 40 Ah
Weight	approx. 42.3 kg (incl. batteries)
Dimensions	W: 450 mm H: 350 mm D: 180 mm

960006.10.GB

External power supply 7 A / 24 V DC 28Ah EN 54-4

Batteries for power supplies ZSP135-DR should be ordered separately.

Technical Data

Output current	max. 7 A
Rated Output Current	5.5 A
Battery capacity	max. 28 Ah
Weight	approx. 28.3 kg (incl. batteries)
Dimensions	W: 390 mm H: 350 mm D: 140 mm

960007.10.GB

External power supply 7 A / 24 V DC 40Ah EN 54-4

Batteries for power supplies ZSP135-DR should be ordered separately.

Technical Data

Output current	max. 7 A
Rated Output Current	5 A
Battery capacity	max. 40 Ah
Weight	approx. 42.3 kg (incl. batteries)
Dimensions	W: 450 mm H: 350 mm D: 180 mm

960008.10.GB

External power supply 7 A / 24 V DC 17Ah EN 54-4

Batteries for power supplies ZSP135-DR should be ordered separately.

Technical Data

Output current	max. 7 A
Rated Output Current	5 A
Battery capacity	max. 17Ah
Weight	approx. 42.3 kg (incl. batteries)
Dimensions	W: 450 mm H: 350 mm D: 180 mm

HLSPS-DB2

NEW



Features

- Modular structure for stand-alone or esserbus operation
- 2 inputs for monitoring external facilities
- Selection of the batteries to be monitored using DIP switches
- Optional connection in the esserbus via adapter board with alarm transponder
- Simple status analysis via LED displays on the base board

External power supply DB2

Approval: VdS

The external power supply unit DB-2, built into a powder-coated metal housing, offers space for up to two 12 V / 45 Ah batteries. A connection to the fire alarm control panels IQ8Control and FlexES Control can be made directly via the optional adapter board (part no. HLSPS-ADPTR) with an esserbus® alarm transponder (part no. 808623). Alternatively, a relay output with floating changeover contact is available for the transmission of faults (mains, battery and collective faults as well as earth fault). DB-2 offers external LED display for operation and collective fault in the lockable front door, internal LEDs for detailed detection of emergency power operation, individual monitoring of battery failure, ground fault, deep battery discharge as well as system errors and mains failure. The settings for battery capacities and combinations are made via DIP switches on the base board of the DB-2.

Technical Data

Rated voltage	230 V AC
Rated frequency	50 ... 60 Hz
Output voltage	20 ... 29 V DC
Battery capacity	7 Ah, 12 Ah, 17 Ah, 26 Ah, 38 Ah, 45 Ah
Output current	max. 4.0 A
Contact load relay	1A / 125 V AC, 60 V DC
Ambient temperature	-5 °C ... 40 °C
Type of protection	IP 30
Color	gray, similar to RAL 7035
Weight	approx. 9 kg (without batteries)
Dimensions	W: 417 mm H: 490 mm D: 206 mm



incl. jumper for series connection of the accumulators

Accessories

HLSPS-ADPTR Adapterplatine	
808623	esserbus alarm transponder
018011	Akkumulatoren 12V DC 12 Ah
018006	12V DC 24 Ah
018009	12V DC 38 Ah

HLSPS-ADPTR

NEW

External power supply DB2

The adapter board is an option for the HLSPS-DB2 power supply if more than one fault relay is required. The adapter board is equipped with a relay for mains, battery and collective faults as well as earth faults. In order to connect the DB-2 to the ESSER loop, the adapter board and the esserbus® alarm transponder (item no. 808623) are required. The optional transponder is plugged onto the adapter board and the power supply unit is thus integrated into the esserbus®. The fault relays are designed as changeover contacts, so the relays can still be used while the esserbus® alarm transponder is attached.

Technical Data

Ambient temperature	-10 °C ... 50 °C
Storage temperature	-10 °C ... 75 °C
Weight	approx. 90 g
Dimensions	W: 85 mm H: 130 mm D: 20 mm
Declaration of Performance	DoP-0755891811

781335

DC/DC converter 12 V/24 V DC



Approval: VdS

This converter generates 24 V as power supply for special detectors. The input voltage of 12 V is taken from the FACP or an external 12 V power supply. Mounted inside the FACP (mounting kit Part No. 788605), this module can supply up to 4 special detectors with a maximum current of 125 mA each or 1 special detector with 500 mA. This module can be integrated in cabinets (Part No. 120240, 788600 and 788601). Please pay attention to the primary current consumption (12 V) in case of mains failure.

Features

- Each output is separately fused

Technical Data

Operating voltage	9 ... 15 V DC
Output voltage	24 V DC \pm 10 %
Output current	max. 500 mA (4 x 125 mA)
Ambient temperature	-10 °C ... 50 °C
Storage temperature	-15 °C ... 55 °C
Air humidity	< 95 % (non-condensing)
Type of protection	IP 40 (housing)
Weight	approx. 150 g
Dimensions	W: 65 mm H: 72 mm D: 20 mm
Declaration of Performance	DoP-20616130701

781336

DC/DC converter output voltage 12 V DC



Approval: VdS

This converter generates 12 V as "electrically isolated" power supply for one special detector. The input voltage of 12 V is taken from the FACP or an external power supply. This module can be integrated in cabinets (Part No. 120240, 788600, 788601 and 788603.10). Please pay attention to the primary current consumption (12 V) in case of mains failure.

Features

- Direct current potentials are electrically isolated
- Voltage interface, for instance, for operating transponders connected to an extinguishing control panel 8010 Series 3 configured for 12 V DC operation
- Suitable for max 1.5 mm² connection terminals
- Short circuit resilient

Technical Data

Operating voltage	10 ... 28 V DC
Output voltage	12 V DC \pm 10 %
Output current	max. 800 mA
Ambient temperature	-10 °C ... 50 °C
Storage temperature	-15 °C ... 55 °C
Air humidity	< 95 % (non-condensing)
Type of protection	IP 40 (housing)
Weight	approx. 70 g
Dimensions	W: 65 mm H: 72 mm D: 20 mm
Declaration of Performance	DoP-20617130701

 The module can also be used in explosion endangered zones for the galvanic separation of the esserbus voltage supply.

781337

DC/DC converter output voltage 24 V DC



Approval: VdS

This converter generates 24 V as power supply for one special detector. The input voltage of 12 V is taken from the FACP or an external power supply. This module can be integrated in cabinets (Part No. 120240, 788600, 788601 and 788603.10). Please pay attention to the primary current consumption (12 V) in case of mains failure.

Features

- Direct current potentials are electrically isolated
- Suitable for max 1.5 mm² connection terminals
- Short circuit resilient

Technical Data

Operating voltage	10 ... 28 V DC
Output voltage	24 V DC \pm 10 %
Output current	max. 400 mA
Ambient temperature	-10 °C ... 50 °C
Storage temperature	-15 °C ... 55 °C
Air humidity	< 95 % (non-condensing)
Type of protection	IP 40 (housing)
Weight	approx. 70 g
Dimensions	W: 65 mm H: 72 mm D: 20 mm
Declaration of Performance	DoP-20617130701

Power Supplies

The listed lead storage battery are maintenance-free, sealed electrolyte batteries. They are relatively position-independent (should not be charged upside-down), deep-cycled, cycle-resistant and long-lasting (4 to 5 years). Charge voltage at an ambient temperature of +20°C: 12 V DC (6 x 2.3 V per cell) 13.8 volts, this can be subject to tolerances.

Technical data sheets are available on demand.

 The batteries comply with the VDE 0833-1 regulations for hazard alarm systems and are VdS approved.

018001 **Battery 12 V DC/1.2 Ah capacity**

018002 **Battery 12 V DC/2.1 Ah capacity**

018004 **Battery 12 V DC/7 Ah capacity**

018011 **Battery 12 V DC/12 Ah capacity**

 2 x Fast-on adapters from 6.3 mm to 4.3 mm

018006 **Battery 12V DC/24Ah capacity**

 2x Fast-On Adapter from M6 by 6.3mm each 2x M5 hex bolt/washers and snap ring

018007 **Battery 12 V DC/17 Ah capacity**

 2 x Fast-on adapters from M6 to 6.3mm each 2 x M5 hexagon head cap screws, washers and snap rings.

018009 **Battery 12 V DC/38 Ah capacity**

 2 x Fast-on adapters from M6 to 6.3mm each 2 x M6 hexagon head cap screws, 4 x washers and snap rings.

Power Supply - Accessories

805597 **3.6 V Lithium battery**

4 Lithium batteries for use in wireless detector base (Part No. 805593.10), wireless gateway for detectors (Part No. 805594.10) and wireless universal interface (Part No. 805601.10/805602.10).



 4 pcs



Displays and Operating Units

LED Indicator Panel

LCD Indicator Panel

System 3000

1

2

3

4

5

6

7

8

9

10

11

36

12

37

13

38

14

LED Indicator Panel

764790



Standard LED remote indicator panel

Approval: VdS

Additional indicator for up to 32 alarm, trouble or collective signals. Connection via an integrated 32-pin terminal strip. The indicator is controlled via relay contacts or semiconductor outputs with positive-guided contacts in the hazard detection system. With key for lamp testing, integrated buzzer and easy-to-maintain terminal card. Elegant plastic housing for surface mounting.

Technical Data

Operating voltage	10 ... 15 V DC
Quiescent current @ 12 V DC	approx. 1 mA
Alarm current @ 12 V DC	approx. 380 mA (incl. 32 LED & buzzer)
Display	32 LED, red
Connection terminal	max. 1.5mm ²
Ambient temperature	-5 °C ... 50 °C
Storage temperature	-25 °C ... 75 °C
Air humidity	< 95 % (non-condensing)
Type of protection	IP 40
Housing	ABS plastic
Color	white (similar to RAL 9003), front blue (similar to RAL 5003)
Weight	approx. 1000 g
Dimensions	W: 270 mm H: 221 mm D: 71 mm

 This indicator panel is not suitable for application as an initial warning device for the fire brigade.

804791



Loop LED remote indicator panel for 32 messages

Approval: VdS

Same as 764790, but with integrated and wired esserbus transponder 32 LEDs for operation as a remote indicating panel for the esserbus. For connection to the esserbus and powered loop in fire alarm systems 8000, IQ8Control or FlexES Control.

Technical Data

Operating voltage	10 ... 15 V DC
Quiescent current @ 12 V DC	approx. 1 mA
Alarm current @ 12 V DC	approx. 380 mA (incl. 32 LED & buzzer)
Display	32 LED, red
Connection terminal	1.5 mm ²
Ambient temperature	-5 °C ... 50 °C
Storage temperature	-25 °C ... 75 °C
Air humidity	< 95 % (non-condensing)
Type of protection	IP 40
Housing	ABS plastic
Color	white (similar to RAL 9003), front blue (similar to RAL 5003)
Weight	approx. 1000 g
Dimensions	W: 270 mm H: 221 mm D: 71 mm

 Isolator (Part No. 788612) not included, please order separately.
This indicator panel is not suitable for application as an initial warning device for the fire brigade.

LCD Indicator Panels

784743.CZ

Fire department indicating panel FAT3000, Czech

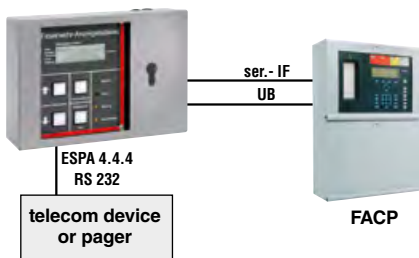

Approval: VdS

Microprocessor-controlled fire department indicating panel in compliance with DIN 14662 as an additional indicator for fire alarm panels. Serial connection to the fire alarm panel via variable interfaces TTY, DUAL RS 485, RS232 and ESPA 4.4.4 (on board), conventional and redundant activation, plain text display with 4 x 20 characters, collective LED indication (alarm, trouble, deactivation). Simple handling with 4 buttons (buzzer OFF/level/scroll buttons). Additional text (> 4000 texts) can be programmed using a PC with serial interface connection, event memory, redundancy via loop structure for up to 16 FAT, power supply and signaling pathway are monitored to prevent short or open circuits, full functional range during breakdown of one circuit. The ESPA interface enables direct connection of telecommunication and paging systems.

Technical Data

Operating voltage	8 ... 30 V DC
Quiescent current @ 12 V DC	approx. 65 mA
Alarm current @ 12 V DC	approx. 125 mA
Ambient temperature	-5 °C ... 40 °C
Storage temperature	-10 °C ... 60 °C
Type of protection	IP 30
Housing	sheet steel
Color	gray, similar to RAL 7032
Weight	approx. 3.5 kg
Dimensions	W: 255 mm H: 185 mm D: 58 mm

The module can only be used when combined with a System 8000 or IQ8Control Fire Alarm Control Panel.

Programming software "FatProgWin" is included.

Indicator and Operating Panels in Metal Cabinets

784725.PL

FB information and operating system, DIN A4, Polish



Sheet steel housing with two doors for surface mount or flush mount installation with central door opening for both door. The right-hand housing door can be individually opened by means of a built-in CL1 lock. Door opening through fire brigade lock (suitable for half profile cylinder installation). In the left-hand door of the housing, a 784743 fire service indicator panel and a fire service operating panel 784710 are installed. The housing is designed for holding a transmission unit or a manual call point. The fire service indicator panel is actuated via the serial interface in the control panel. The fire service operating panel is connected to the control panel interface. A maximum of 2 x 100 DIN A4 / horizontal layout fire brigade route maps can be integrated.

Technical Data

Operating voltage	10 ... 30 V DC
Quiescent current @ 12 V DC	approx. 50 mA
Alarm current @ 12 V DC	approx. 180 mA
Ambient temperature	-5 °C ... 40 °C
Storage temperature	-10 °C ... 60 °C
Type of protection	IP30
Housing	sheet steel
Color	red, similar to RAL 3000
Weight	approx. 15 kg
Dimensions	W: 710 mm H: 560 mm D: 100 mm

Only in combination with the System 8000, IQ8Control fire detection panels. For redundant operation, redundancy module ADP-N3E (Part No. 784744) is required.

Double-door sheet steel housing
 Fire service indicating panel 784743
 Fire service operating panel 784710

Adapter Modules

784744



Features

- Input: TTY from the internal FACP interface
- Output: DUAL RS 485 to the FAT interface

Adapter module ADP-N3E

Microprocessor-controlled module for installation (mounting rail) in System 8000 or IQ8Control fire alarm panels. In compliance with DIN 14675, the TTY interface can be used for redundant transmission when the adaptor is connected and when the fire department indicating panel FAT3000 is used for initially informing the fire department. Additional text (> 4,000 texts) can be programmed using a PC with serial interface connection.

Technical Data

Operating voltage	8 ... 30 V DC
Quiescent current @ 12 V DC	approx. 55 mA
Contact load relay	30 V DC / 1 A
Connection terminal	max 2 x 0.8 mm ²
Ambient temperature	-5 °C ... 40 °C
Storage temperature	-10 °C ... 60 °C
Weight	approx. 100 g
Dimensions	W: 80 mm H: 150 mm D: 30 mm

 The top hat rail module (part no. 788652) and the module housing for snap-on mounting rail (part no. 788603.10) can be used for installation. The interface is compatible with FAT3000 (784743). Power is supplied by the fire alarm panel or an external power supply unit. Maximum data line length: 800 m.

784753



Adapter module ADP-PRS-422

Additional module for connecting a paging system to a series 8000/IQ8Control fire alarm system with ADP-N3E. To connect the paging system via an electrically isolated RS 232 interface, an ADP-PRS-422 is used.

Technical Data

Operating voltage	8 ... 30 V DC
Quiescent current @ 12 V DC	approx. 5 mA
Dimensions	W: 100 mm H: 80 mm D: 20 mm

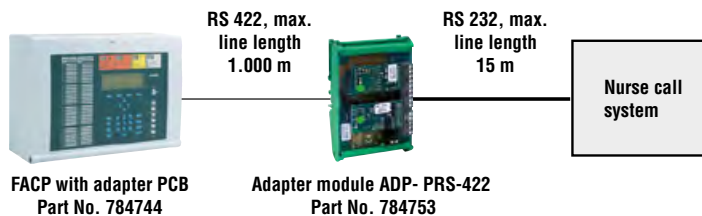

Connection example

784871

NEW



Features

- With galvanic isolation

Module with RS422/RS485 interface

Module with selectable interface RS422 or RS485.

Technical Data

Operating voltage	3.3 V DC
Current consumption	35 mA
Dimensions	W: 27 mm H: 53 mm D: 15 mm

784872

NEW



Module with interface M4-TTY

Module with preset interface M4-TTY.

Technical Data

Operating voltage	3.3 V DC
Current consumption	20 mA
Dimensions	W: 27 mm H: 53 mm D: 15 mm



- 1
- 2
- 3
- 4
- 5
- 6
- 7
- 8
- 9
- 10
- 11
- 12
- 13
- 14

Network Technology

essernet

40-44

The essernet is a short circuit and open circuit resistant 2-wire backbone for networking fire detection panels from the ESSER product range. The essernet permits both hierarchy-restricted and hierarchy-free programming of panels. The essernet has been tested and approved by the VdS. The hardware components are listed in the respective equipment approvals of the fire detection panels.

Up to 31 panels can be networked with each other in a ring loop. Superior functions and functions covering different panels can be programmed. The status of the entire system can be read off on anything from one to all panels as desired. Likewise, the system can be operated entirely from one panel.

Networking can be carried out via a simple telecommunication cable, e.g. IY-ST-Y 2 x 0.8 mm, with 784840.10 or using a data cable, e.g. IBM type 1 as well as CAT5 cable, with 784841.10. With the essernet repeaters, cable distances of up to 3000 m between two panels are possible. An optical waveguide fibre is possible with the converters, which are listed below.

Third-party or management systems (e.g. WINMAGplus) can be connected via the serial essernet interface.

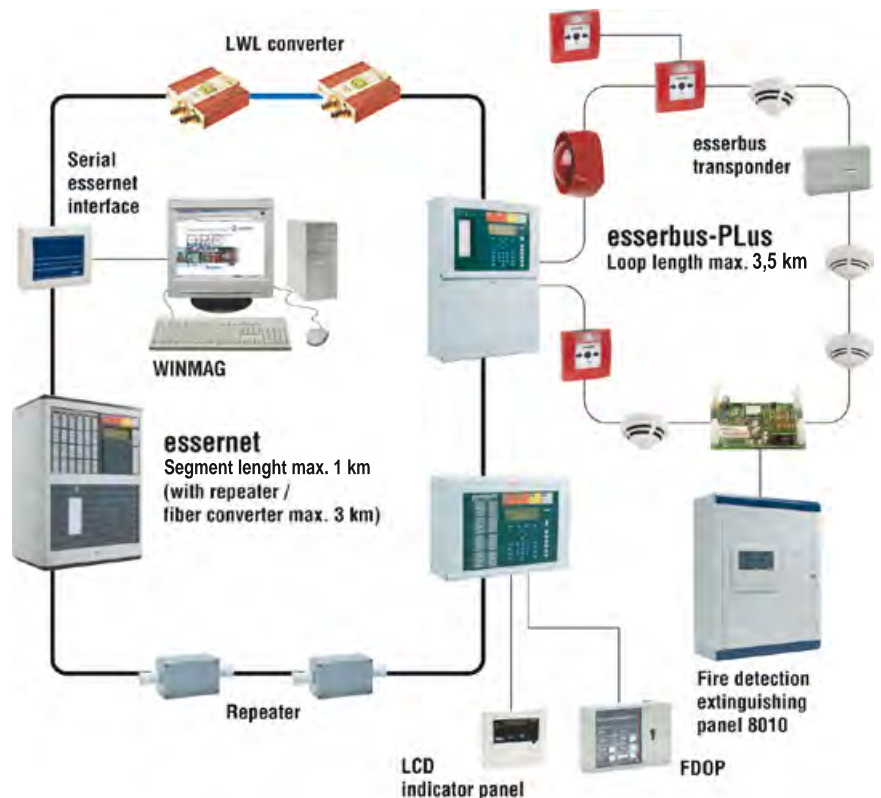

Application example

784840.10

essernet® module, 62.5 kBd for IQ8Control



Network interface module for max. 16 network participants.
Topology: Ring structure, interruption and short-circuit tolerance

Technical Data

Quiescent current @ 12 V DC	approx. 150 mA
Cable	telecommunications cable I Y (St) Y n x 2 x 0.8 mm
Cable length per segment	1000 m (max. between 2 users)

784841.10

essernet® module, 500 kBd for IQ8Control



Network interface module such as essernet module Item no. 784840.10, however for max. 31 network participants.

Technical Data

Quiescent current @ 12 V DC	approx. 150 mA
Cable	IBM type 1,2,6 or similar (e.g. BELDEN 1634A)
Cable length per segment	1000 m (IBM Typ1 max. between 2 users), max. 400 m when Cat3 cable or higher

784865

essernet repeater, 62.5 kBd



Approval: VdS

The essernet repeater increases the maximum distance between two FACP in the essernet by up to 1000 m. Standard telephone cables can be used as connection leads. Two repeaters can be operated in line.

Technical Data

Operating voltage	8 ... 18 V DC
Current consumption @ 12 V DC	approx. 100 mA
Ambient temperature	-10 °C ... 70 °C
Storage temperature	-20 °C ... 80 °C
Cable	telecommunications cable IY(St)Y n x 2 x 0.8 mm
Type of protection	IP65
Housing	die-cast aluminum
Air humidity	< 95 % (non-condensing)
Color	gray
Weight	approx. 520 g
Dimensions	W: 125 mm H: 60 mm D: 80 mm
Declaration of Performance	DoP-20619130701

784843

essernet repeater, 500 kBd



Approval: VdS

As 784865, but with 500 kBd baud rate. IBM type 1, type 2 or type 6 cables can be used as connection leads or similar.

784768

NEW



Features

- Two multimode fibers required per network section
- Glass fibre G50 / 125 µm: attenuation max. 10 dB, distance up to 4000 m
- Glass fibre G62.5 / 125 µm: attenuation max. 10 dB, distance up to 4000 m

Multimode FO converter ST

Approval: VdS

Depending on the fiber used, distances of up to 4 km are possible. Suitable for multimode fibres G50/125 µm and G62,5/125 µm.

Technical Data

Operating voltage	9.5 ... 48 V DC
Current consumption @ 12 V DC	approx. 140 mA
Current consumption @ 24 V DC	approx. 75 mA
Ambient temperature	-10 °C ... 60 °C
Storage temperature	-20 °C ... 75 °C
Wavelength	850 nm
FO-Connector	ST
Type of protection	IP20
Housing	aluminum unpainted
Installation	mounting rail
Weight	approx. 320 g
Dimensions	W: 65 mm H: 100 mm D: 22 mm

 The power supply of the fibre optic converter must be provided by the FACP. On both sides of a fibre optic line, fibre optic converters of the same type must always be used.

-  1x FO converter 784768
- 1x DIN rail mounting kit
- 1x connecting cable max. 1,8 m converter - essernet®-module

784769

NEW



Features

- Two single-mode fibers are required per network section
- The fibers must be connected directly without interruption (e.g. no connection via multiplexers permitted)
- Fiber type E9/125 µm; max. permitted attenuation of 17 dB corresponds to a length of approx. 30 km or
- Fiber type E10/125 µm; max. permitted attenuation of 17 dB corresponds to a length of approx. 30 km
- Up to 16 FOC connections per essernet network at a transfer rate of 62.5 kBd
- Up to 31 FOC connections per essernet network at a transfer rate of 500 kBd with LWL-converter possible

Singlemode FO converter ST

Approval: VdS

For networking of fire alarm control panels via fiber optic cable, one essernet module and at least one fiber optic converter is required per FACP. The fiber optic converter must be mounted directly in the housing or in a built-in cabinet of the FACP. For this purpose, it is mounted directly on a DIN rail, without any further fastening material.

Technical Data

Operating voltage	9.5 ... 48 V DC
Current consumption @ 12 V DC	approx. 140 mA
Current consumption @ 24 V DC	approx. 75 mA
Ambient temperature	-10 °C ... 60 °C
Storage temperature	-20 °C ... 75 °C
Wavelength	1310 nm
FO-Connector	ST
Type of protection	IP20
Housing	aluminum unpainted
Installation	mounting rail
Weight	approx. 320 g
Dimensions	W: 65 mm H: 100 mm D: 22 mm

-  Prefabricated connection cable 1.8 m (connection essernet module - FACP)

Accessories

- 788602 Top hat rail

784855

SEI serial essernet interface EDP, unidirectional



Features

- Serial data rate 19.2 kBd
- RS 485 interface on-board for a max. length of 1,000 m

The serial essernet interface can be used as a gateway to link remote computers that support the ESSER data protocol (EDP). The EDP version (unidirectional) is only provided with information from the essernet, remote control is not possible. The unit includes a slot for an essernet module and is therefore a fully functional unit within the short circuit and open circuit resistant essernet.

Technical Data

Operating voltage	10.5 ... 28 V DC
Current consumption @ 12 V DC	approx. 60 mA
Current consumption @ 24 V DC	approx. 30 mA
Ambient temperature	-5 °C ... 50 °C
Storage temperature	-10 °C ... 50 °C
Air humidity	< 95 % (non-condensing)

 The essernet micromodule and the interface module are not included and must be ordered separately in accordance with the required essernet type and the serial transmission standard.

Accessories

- 788606 Housing kit
- 772386 Interface-module RS 232/V 24
- 772387 Interface-module TTY/CL 20 mA
- 784840.10 essernet micromodule (62.5 kBd)
- 784841.10 essernet micromodule (500 kBd)

784856

SEI serial essernet interface EDP, bidirectional



as 784855, but bidirectional with remote control options e.g. for the connection to a Building Management System (BMS)

Accessories

788606



Housing for SEI

Housing for the serial essernet interface (SEI).

Technical Data

Type of protection	IP31
Housing	ABS plastic
Color	white similar to RAL 9003, front blue similar to RAL 5003
Dimensions	W: 270 mm H: 221 mm D: 71 mm

772386



Interface-Module RS232 / V24

For the serial essernet interface for a length up to 15 m.

772387



Interface module TTY/CL 20 mA

For the serial essernet interface for a length up to 1,000 m.

013405.20



Hardware option TCP/IP converter, Ethernet RS232 / RS485

This hardware option is used to connect a remotely a stand-alone FACP or an essernet FACP network essernet via a (for example) company-wide Ethernet LAN to a MBS Management Building System e.g. WINMAG plus control center via TCP/IP. This allows the device to be used as a protocol converter between the SEI contained on the essernet and the WINMAGplus control center available in the Ethernet LAN.

Technical Data

Operating voltage	12 ... 48 V DC
Ambient temperature	0 °C ... 55 °C
Storage temperature	-20 °C ... 75 °C
Air humidity	< 95 % (non condensing)
Housing	metal
Weight	approx. 340 g
Power consumption	1.5 W
Dimensions	W: 52 mm H: 80 mm D: 22 mm (housing) W: 75.2 mm H: 80 mm D: 22 mm (with tabs)

Features

- Transmission with RS232 max. length 15 m and with RS485 max. length 1,000 m
- Serial interface: RS232, RS422 or RS485 (2- and 4-wire), configurable via software
- Transmission speed: 300 bauds to max. 230 kBaud configurable via software
- Serial connection: D-Sub 25, socket
- Ethernet interface: 10Base-T/100Base-TX
- Transmission speed: 10/100/auto Mbit, configurable via software
- Mode of transmission: half- /full-duplex or automatic, configurable via software
- Network access: RJ45
- Supported protocol: ARP, UDP, TCP, ICMP, Telnet, TFTP, AutoIP, DHCP, HTTP, SNMP, TCP, UDP and Telnet, TFTP



System requirements for operation and software configuration: Windows® 2000 / XP. Bidirectional or unidirectional data transfer depends on the SEI used, thus serial essernet interface EDP unidirectional Part No. 784855 or bidirectional Part No. 784856. Up to 10 TCP/IP converters can be connected per PC (Personal Computer).

For the direct connection of the Management Building System via the PC Com interface to the internal interface of the FlexES Control panel, please use the RS485 / R232 converter Part No. 784852.



Hazard Management System

WINMAGplus

46-54

WINMAGLite

55

Difference WINMAGLite vs. WINMAGplus

56



Features

- Compatible with Windows XP Professional SP2; Windows of 2003 servers; Windows Vista, 7 and 8
- Modular construction and freely programmable
- Direct control of the network devices
- List of measures to be taken for fire-fighting forces

- Individual allocation of usage rights incl. priority scheduling
- Integrated simulation-functions
- Extensive recording of events and operations
- Visualization of messages
- Up to 12 active graphics simultaneously representable

- Integration of video sequences possible
- Information output via Windows print manager to multiple printers etc.
- Time program/calendar function
- Integrated database standard
- Activation of other programs from WINMAGplus possible
- Efficient programming language (SIAS) for customer-specific adjustment of interface and processes in case of alarm
- Remote control possible via modem (optional)
- 10 printers per workstation possible
- Multiple monitors can be used. 4 of 8 screens may be selected.

Windows management system for hazard detection systems

WINMAGplus has been specially developed to meet the requirements of managing and integrating hazard detection systems on a single PC platform. WINMAGplus simultaneously manages and displays graphically a number of security applications, using a common user interface including: fire detection technology; voice alarm public address; intrusion detection technology; access control technology; video technology; rescue route technology/escape door control, personnel protection systems and locating systems as well as fence monitoring systems. Apart from security systems, a multitude of building management control systems such as lighting, elevator control and fault detection systems as well as door/gate/barrier control systems can be managed and graphically displayed.

Database and user interface are designed in line with current standards: messages are displayed both graphically and in text format. WINMAGplus offers various application options, ranging from clearly displayed messages to active control of all detection devices. Based on our security networks IGIS-Loop and essernet, WINMAGplus is not only a highly professional system but also the best possible integrated visual data and management solution.

Program:

Thanks to its modular design, WINMAGplus offers suitable software for systems of any size and type of application, ranging from WINMAGplus basic package for single-station systems with one subsection being connected to the WINMAGplus multi-station system with multiple subsections being connected. Licensing enables the program options purchased and it legitimises program use. A dongle is acquired together with a license. The dongle must be plugged into a parallel interface or into a USB port of the WINMAGplus computer. With multi-station systems, every computer that is networked must be equipped with a dongle. Workstations that are not networked do not need a dongle. If the dongle is removed during operation, WINMAGplus runs for max. 72 hours in online mode.

Our services for installers:

Our WINMAGplus services include everything from entering alarm points to generating diagrams. First of all, operators are made familiar with WINMAGplus. Then we work out the specifications together with the customer and develop SIAS programs. We design complete application packages and train your personnel. Until the final acceptance, we offer support for all installation processes and assist you during daily operation via a remote maintenance tool if required.

Interfaces, drivers:

Besides our security system drivers included in our product catalog, we offer a variety of drivers for all kinds of trades and manufacturers. Due to the continuously rising number of drivers, the current list of drivers can be requested when required. If the driver you need is not available, we will develop a driver geared to your requirements. Alternatively, all instruments can be connected via the standard OPC interface. This is an international standard, which is supported by a multitude of manufacturers irrespective of their product lines. For developing your own drivers, we can provide you with the connection server and a developer's package. Thus, individual WINMAGplus drivers can be created.



Hardware and software requirements:

Pentium 3 GHz or higher, minimum 512 MB RAM, minimum 1 GB of hard disk space, XGA graphics card with minimum 4 MB video memory, monitor with min. 1024x768 pixels, sound card with external speakers, Windows XP Professional SP 2, Windows 2003 Server, Vista and Windows 7 & 8, Internet Explorer version 6.0 or higher.

To order WINMAGplus licenses, please use the order form found in the back of the catalog.

013610

Control center software CD WINMAGplus basic kit



WINMAGplus control center software CD for hazard detection systems, license not included, compatible Windows XP Professional (SP3) 32-Bit version, Windows Server 2003 32-/64-Bit version, Windows Vista 32-/64-Bit version, Windows 7 & 8 32-/64-Bit version and Windows Server 2008 32-/64-Bit version. With the aid of this basic software and the corresponding licenses, hazard detection systems can be operated and managed via PC. Hazard reports are indicated in text form and graphically. In this way, the PC can also be used as an electronic emergency control point.

 For demonstration purposes only, the WINMAGplus basic version operates without a license as a full version for a total of twenty 8-hour days, after which the program switches to offline mode. After expiry of the test time, all connections to all components are cut off. Starting in offline mode does not reduce the number of test runs. The demo mode is a full-function editing environment. All components function except the online communication. Each process can also be tested in demo mode through simulation and all editing functions can be used.

Please use order form printed in the appendix.

You can also download this software free of charge from our protected download area at www.hls.austria.com.

Basic Licenses

013631

Basic license for WINMAGplus USB port



This basic license is used to activate the basic software package/demo version to operate as unrestricted visualizing software for server workstations and for network clients. For interfacing control panels to server workstations, further licenses are required (see 013601 – 013606, 013608, 013611, 013613, 013625).

 Please use order form printed in the appendix.

 Dongle for USB port

Upgrade Package

013616

WINMAG upgrade to WINMAGplus



Upgrade of a WINMAG installation from version 6 to the newest WINMAGplus control center software.

For updating WINMAG V1 - 5 please use part no. 013617 in order form.

 Please use order form printed in the appendix.

 License file

013617

WINMAG installation upgrade as of version 6



WINMAG installation upgrade to the most recent WINMAGplus control center software version

An existing WINMAG as of version 6 can be upgraded to the most recent WINMAGplus control center software version. For each installation with dongle (each connected PC) an upgrade version must be separately ordered.

 Please use order form printed in the appendix.

Extension Licenses

013609

WINMAGplus control center software - subsequent upgrade



This order number serves as an auxiliary number for a subsequent optional extension or (e.g. additional client or subsequent connection of video systems) to an existing WINMAG installation from V 6.0. to V10 and WINMAGplus. The appropriate licenses must be ordered separately. The dongle need not be submitted.



Please use order form printed in the appendix.

013601

WINMAGplus license - intrusion detection technology



License option for WINMAG/WINMAGplus basic software. Required if intrusion detection systems are connected to WINMAG.



This license may be ordered separately (subsequently) only in conjunction with the auxiliary number 013609. The update number of the basic license must be included when ordering. The license is used for connection of the Honeywell intrusion detection systems MB/HB, 5008 and Galaxy..

Please use order form printed in the appendix.

013643

WINMAGplus license - Galaxy Dimension



License option for WINMAG/WINMAGplus basic software. Required if Honeywell Galaxy Dimension intrusion detection technology is connected to WINMAG.



This license may be ordered separately (as subsequent optional upgrade) only in conjunction with the auxiliary number 013609. The update number of the basic license must be included when ordering. The license is used for connection of the Honeywell intrusion detection systems.

Please use order form printed in the appendix.

013626

WINMAGplus license - fire detection technology



License option for WINMAG/WINMAGplus basic software. Required if fire detection systems are connected to WINMAG.



This license may be ordered separately (as subsequent optional upgrade) only in conjunction with the auxiliary number 013609. The update number of the basic license must be included when ordering. The license is used for connection of the Honeywell IQ8Control, system 8000 1024, 1016 and FlexES Control fire detection systems.

Please use order form printed in the appendix.

013603

WINMAGplus license - access control



License option for WINMAG/WINMAGplus basic software. Required if access control system devices are to be connected to WINMAG (e.g. ACS 2 and ACS 8). MultiAccess and/or IQ MultiAccess software package is also required.



This license may be ordered separately (as a subsequent optional update) only in conjunction with the auxiliary number 013609. The update number of the basic license must be included when ordering. The license is used for the connection of the Honeywell ACS and (IQ) MultiAccess access control systems.

Please use order form printed in the appendix.

013604

WINMAGplus license - video technology



License option for WINMAG/WiINMAGplus basic software. Required if video technology equipment is to be operated via WINMAG. The crossbars can execute such commands as pan, zoom, tilt, select monitor etc., depending on the model. The following video crossbars are currently supported: Ernitec M 500 and M 1000; Honeywell MaxPRO 32; Philips LTC 8x00; Fusion series II / III; Geutebrück Vicrosoft; Geutebrück Multiscope; Honeywell Fusion; HDPR series; contact your supplier for additional brands.

This license may be ordered separately (as a subsequent optional update) only in conjunction with the auxiliary number 013609. The update number of the basic license must be included when ordering.

Please use order form printed in the appendix.

013605

WINMAGplus license - rescue route technology/escape door control



License option for WINMAG/WINMAGplus basic software. Required if rescue route technology/escape door control equipment (only Honeywell Security) is to be operated via WINMAG.

The status of escape doors is graphically displayed.

This license may be ordered separately (as a subsequent optional update) only in conjunction with the auxiliary number 013609. The update number of the basic license must be included when ordering. The license is used for connecting Honeywell rescue route technology/escape door control equipment.

Please use order form printed in the appendix.

013608

WINMAGplus license - RTD



License option for WINMAG/WINMAGplus basic license. Enables operation of WINMAG via modem, using DS 7600 and DGA 2400 to ESSER IDT (HB and MB series) and fire detection systems (1024 series).

This license may be ordered separately (as a subsequent optional update) only in conjunction with the auxiliary number 013609. The update number of the basic license must be included when ordering.

Please use order form printed in the appendix.

013661

Management software WINMAGPlus licence for Honeywell DTS detector



License option for WINMAG/WINMAGplus basic software. Required if Honeywell DTS linear heat detection systems is connected to WINMAG to receive, visualize fire alarm and fault states from DTS zones.

Connection Server

013606

WINMAGplus license connection server



License option for WINMAG/WINMAGplus basic software. Connection Server is a software module that enables the connection of a 3rd party device to WINMAG. Connection Server offers a convenient interface with which data and control commands can be exchanged bi-directionally in detection point format using WINMAG.

This license may be ordered separately (as a subsequent optional update) only in conjunction with the auxiliary number 013609. The update number of the basic license must be included when ordering.

Please use order form printed in the appendix.

013607

Connection server developers kit



This developers kit can be used to program WINMAG/WINMAGplus connections to third party devices. The package contains the connection server developers kit including full documentation plus a one-day training session in Albstadt (Germany).

Please use order form printed in the appendix.

Dongle for USB port and license file

OPC

013618

Data points package



Package of 500 data points for project-related allocation of OPC tags, ESPA data points, etc.

The data points package can only be ordered in connection with the license 013590 universal gateway for PC and/or license 013611 OPC server.

Please use order form printed in the appendix.

013611

WINMAGplus license – OPC server



Option for WINMAG/WINMAGplus basic software. Required if WINMAGplus is to act as an OPC server.

The OPC server license can only be ordered in conjunction with the 013618 license. This license may be ordered separately (as a subsequent optional update) only in conjunction with the auxiliary number 013609. The update number of the basic license must be included when ordering.

Please use order form printed in the appendix.

013612

WINMAGplus license – OPC client



Option for WINMAG/WINMAGplus basic license. This is required if WINMAG is to display data from devices with OPC interfaces.

This license may be ordered separately (as a subsequent optional update) only in conjunction with the auxiliary number 013609. The update number of the basic license must be included when ordering.

Please use order form printed in the appendix.

Options

013613

Option - notification



License option for WINMAG/WINMAGplus basic license. Required if SMS (text message), fax or e-mail are to be sent from WINMAG.

This license may be ordered separately (as a subsequent optional update) only in conjunction with the auxiliary number 013609. The update number of the basic license must be included when ordering. An ISDN connection (S0) as well as an ISDN card are required for the notification function.

Please use order form printed in the appendix.

013650

Option – escalation



Option for the WINMAG/WINMAGplus basic license. Required if short text messages dispatched by WINMAG are to be acknowledged. Without acknowledgment, pre-programmed escalation plans can be activated.

This license may be ordered separately (as a subsequent optional update) only in conjunction with the auxiliary number 013609. The update number of the basic license must be included when ordering. For the escalation license, the 013613 notification license is required. A PC sound card is required for this function.

Please use order form printed in the appendix.

013652

Option – ability for customized interface rights (client-side)



Option for the WINMAG/WINMAGplus basic license, allowing individual assignment of interfaces and rights to several operators.

This license may be ordered separately (as a subsequent optional update) only in conjunction with the auxiliary number 013609. The update number of the basic license must be included when ordering.

Please use order form printed in the appendix.

013624

Option – redundance



Option for redundant connection of essernet and IGIS-Loop security networks to the WINMAG server. Interface operation for redundant networks is based on master/backup operation and prevents data loss in WINMAG objects in case of disruption of network connections caused by cable defects or COM port failure.

Please use order form printed in the appendix.

013625

Option – client



License option for WINMAG/WINMAGplus basic license. Enables operation of one client station in a computer network with one server workstation. The license must be installed at the server workstation. Clients require only the WINMAG software to be installed. One WINMAG client license is needed per client.

This license may be ordered separately (as a subsequent optional update) only in conjunction with the auxiliary number 013609. The update number of the basic license must be included when ordering.

Please use order form printed in the appendix.

013653

WINMAGplus – 4-monitor support option



Option for WINMAGplus basic license. Enables the allocation of 4 monitors from a choice of 8 monitors. This option only works with WINMAGplus.



This option requires a special graphics card with up to 8 outputs in the WINMAG hardware.

This option must be ordered per workstation which uses the multi-monitor option.

013655

WINMAGplus – AutoCAD option



Option for WINMAGplus basic license. Enables the placement of detectors and groups directly from ACAD LT. The drawings are saved as dxf files. The detectors/groups are placed as hyperlinks in the ACAD drawing and stored. When importing these ACAD drawings into WINMAGplus, the symbols of the disciplines are automatically placed onto the correct position in the drawing. An ACAD license must be provided by the customer.



Please use order form printed in the appendix.

Application Example

1. WINMAGplus single station system with an essernet connection

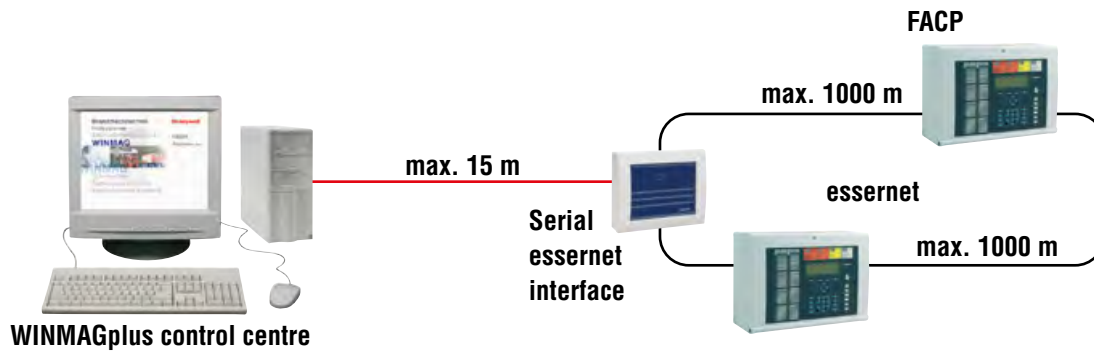

WINMAGplus software requirements:	
1 x CD WINMAGplus control center software	Part No. 013610
1 x Basic license WINMAGplus control center software	Part No. 013631
1 x License fire detection technology	Part No. 013626

2. WINMAGplus multi station system - one server and two clients with an essernet connection

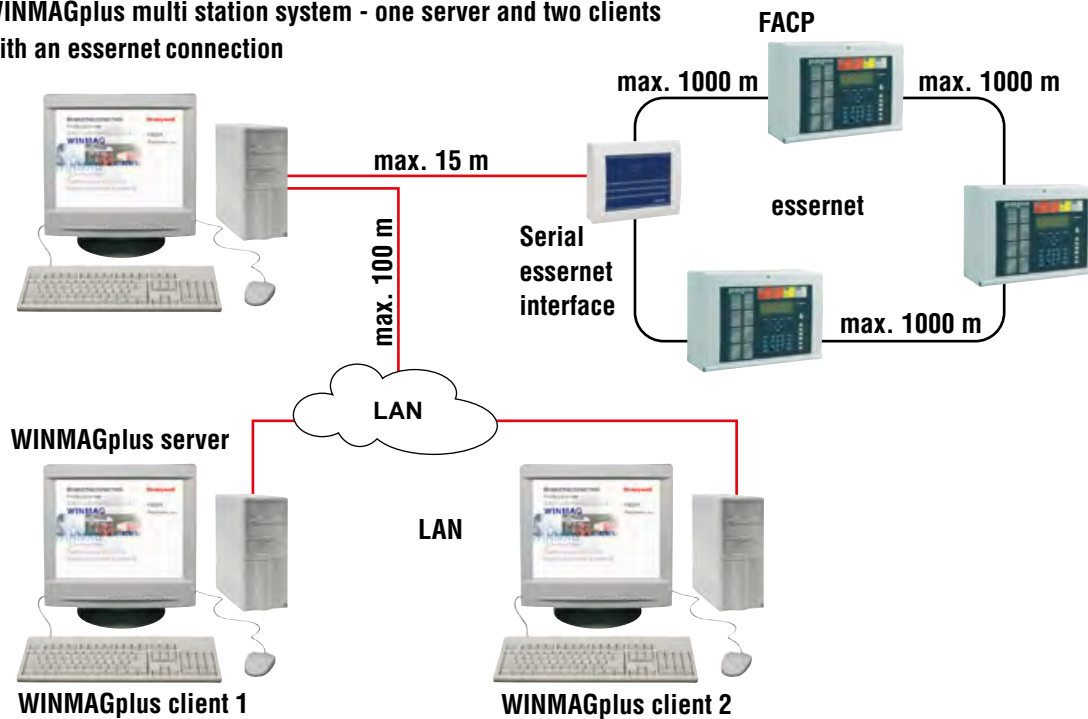

WINMAGplus software requirements:	
1 x CD WINMAGplus control center software	Part No. 013610
1 x Basic license WINMAGplus control center software	Part No. 013631
1 x Licence fire detection technology	Part No. 013626
2 x License WINMAGplus client	Part No. 013625

Application Example

3. WINMAGplus multi station system - one server and two clients with a multi subsection connection

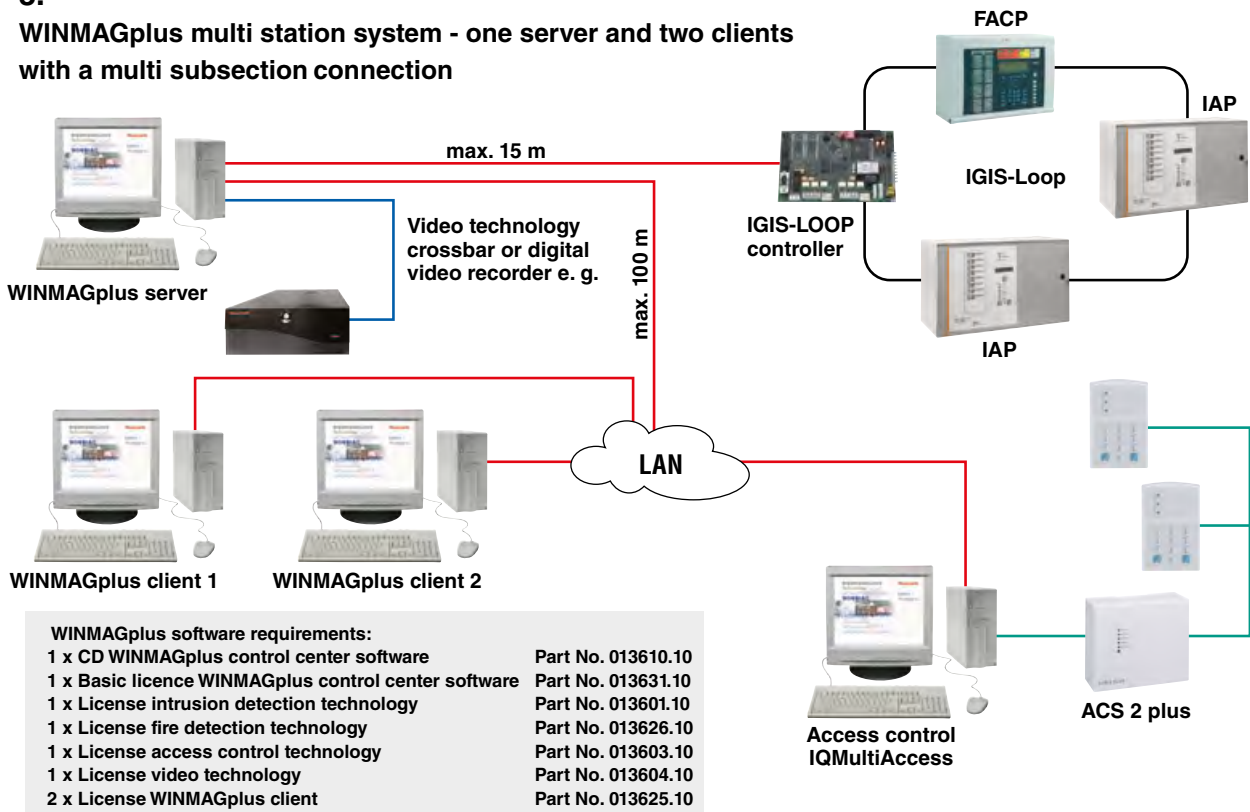

4. WINMAGplus multi station system - 1 main server, 1 redundant server, 3 client workstations - with an essernet connection

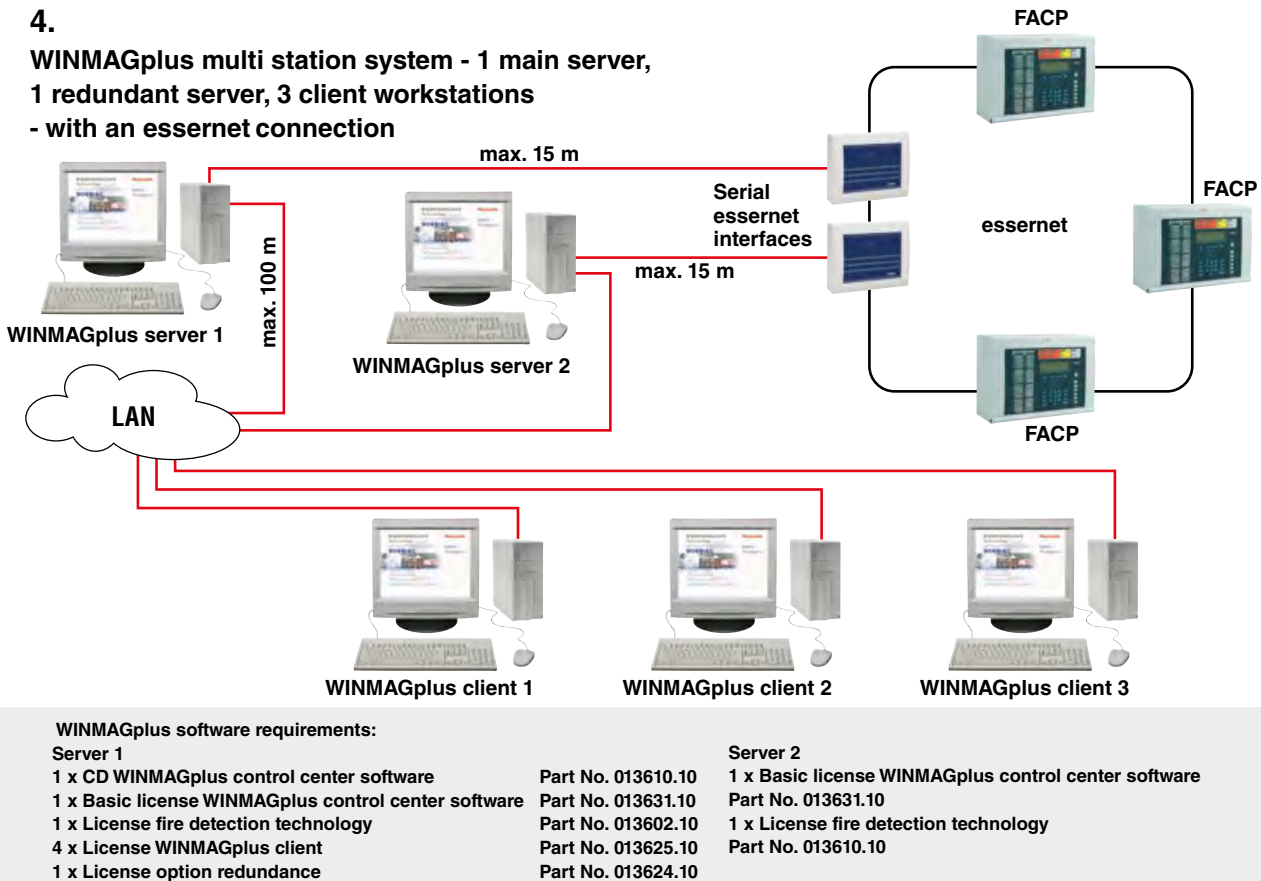



Application example

013635



Features

- Cost-effective management software for hazard detection systems
- Visualizing and controlling of only one hazard detection central control panel (FDS, VAPA, IDS, RRT, AC)
- Visualizing and controlling of VisiOprime or Fusion video management systems
- Management of up to 500 detection points
- Processing of up to 100 status reports per second
- Processing of up to 100 macro processes
- Connection of log and alarm printers
- Information display via monitor and/or printer (Windows standard printer)
- Adjustable program background
- Flexible, window-oriented graphics
- Display and location of detectors in diagrams
- Status information indicators
- Pre-defined alarm reports
- Simulation function
- Extensive event and operation logging
- Users possible

WINMAGLite with USB dongle

WINMAGLite is a cost effective first step to hazard detection systems management. Ease of operability as well as pre-defined, practical central control panel and detection point types facilitate the commissioning and operation of WINMAGLite.

WINMAGLite is perfect for small systems for which no expansions or connection of further hazard detection control panels are planned in the near future. Thus, the Lite version is perfectly suitable for a broad range of applications, even for WINMAG professionals.

Especially small objects can be professionally secured due to a combination of a hazard detection system with the Honeywell video management systems of Honeywell VisiOprime. WINMAGLite provides the user with almost all basic WINMAG functions. Unlike the full version, this version can initially connect only one hazard detection central control panel.

The user has access to pre-defined programs which can automatically be adjusted via a text editor to the respective situation on site.

The alarm stack which was implemented in previous WINMAG versions is replaced through symbols displayed in the top bar which indicate alarms. The new feature improves overall clarity so that the user can react more quickly in the case of an alarm.

Hardware and software requirements:
Pentium processor 3 GHz or higher, min. 512 MB RAM, min. 1 GB hard disk, XGA graphics card with min. 4 MB video memory, monitor with 1024 x 768 pixels or more, sound card with external speakers, Windows XP Professional SP2, Vista, Windows 7 & 8 and Windows 2003 Server, Internet Explorer 6.0 or higher.

Please use order form printed in the catalog.

Training for this product is offered. Please contact our training department.

Basic CD control center software package WINMAGLite

Accessories

Please take note that for connecting one essernet is needed consisting of SEI and fire alarm system.

013636



WINMAGLite upgrade to WINMAGplus full version

If the WINMAGLite system limits have been reached, an upgrade to the full version of Winmagplus is possible, since both systems have access to the same database. WINMAG options are not part of the upgrade and must be ordered separately.

WINMAGplus options are not included in the upgraded version and must be ordered separately.

Please use order form on www.esser-systems.com.

Difference WINMAGLite vs. WINMAGplus

Differences between WINMAG Lite and WINMAG plus





WINMAG Lite is the inexpensive starter version of the hazard management system WINMAG plus with reduced features. It is used for visualization and control of a single hazard detection control panel. The following table shows the most important features of both programs.

















In this comparison, you can see whether WINMAG Lite is sufficient for an application or WINMAG plus must be used.

The data structure of WINMAG Lite and WINMAG plus is identical. It is possible to change from WINMAG Lite to the full version.

	WINMAG Lite	WINMAG plus
Item No.	013635	013630/13631+ Options
Interfaces	1 hazard detection control + any Fusion video devices	as desired, depending on options
I/O points per object	500	32000
Setting of I/O points	individual	individual
Special I/O Types	yes	yes
Event display	yes	yes
Meta data	yes	yes
Alarm stack	not available	yes
User	3 predefined, can be renamed	unlimited, free definable
Tool bars	predefined	configurable
SIAS-programs	predefined, no special programs	configurable, extensible
SIAS language	no individual programming	full featured
Alarm display	counter and pop-ups with individual text	identical to WINMAG Lite, in addition alarm programs with alarm stacks
Alarm criteria	predefined	configurable
Graphics	identical to WINMAG plus, but without - multi-monitor - AutoCAD	several formats like - bmp, jpg, png, emf, wmf - AutoCAD-Integration (optional)
Supported monitors	2	4 from 8 (optional)
Number of graphics	unlimited	unlimited
Graphics displayable at once	13	48
Symbol actions	predefined list	configurable, special functions
Creating special symbols	no	yes
Multi station functions	no	yes
Mandantory	no	yes
Timer programs	no	yes
State monitoring	no	yes
Printer allocation	1	15
Licensing	dongle without options	dongle with options

System configuration list

-  Change display options
-  Change network configuration
-  Edit I/O device types
-  Edit alarm reasons

-  Change general options
-  Change display options
-  Change network configuration
-  Setup printer
-  Edit user groups
-  Edit users
-  Edit clientele
-  Edit toolbars
-  Edit symbols
-  Edit I/O device types
-  Edit alarm reasons
-  Edit log types
-  Edit time programs
-  Edit state monitoring
-  Edit calendar
-  Edit time zones
-  Edit SIAS program
-  Edit SIAS macros



Automatic Detectors

Series ES Detect (Intelligent non-addressable)

58-61

Series IQ8Quad (Conventional)

62-73

Intrinsically Safe

74-79

Base Series IQ8Quad, ES Detect

80

Accessories

81-93

Automatic Detectors

Series ES Detect (Intelligent non-addressable)

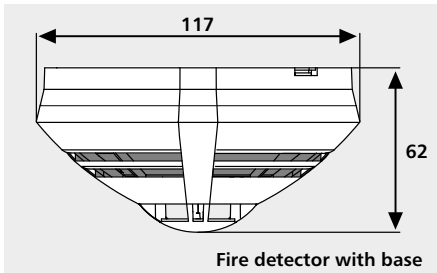

Features

System benefits:

- With multisensor detectors for the detection of all fires, even under the most difficult operating conditions
- Up to 30 detectors per detection group.

Reliable detection:

- Uniform response sensitivity of the detector for all different types of fire for the multisensor detectors
- Large distance between signal and interference magnitudes due to special sensor and electronics design for suppressing electromagnetic influences
- Automatic adaptation to varying environmental influences
- Electronic compensation of long-term influences of contamination or aging

Reliable false alarm suppression:

- High reliability against false alarms by temporal evaluation of different sensor criteria
- Exclusion of signal forms not typical of fires through special filter algorithms
- Automatic self-monitoring of the detector electronics
- Automatic self-monitoring of sensors for function and condition

Maintenance:

- Designation of the heat detector by a black ring on the light pipe
- Hours of operation, alarm and fault counter in each detector
- Operation data retrieval of all detectors of a group with standard service PC and field bus interface
- Detector LED for alarm display and as an identification display in the service (for maintenance with 8000 tools)

Wide range of accessories:

- Standard socket and relay base
- Socket adapter for ceiling installation
- Dust caps optional for fire detectors and detector base
- Kit for suspended mounting

The ES Detect automatic detector is an intelligent non-addressable detector specifically designed for operation on conventional detector groups. ES Detect sets new standards in conventional technology through high quality sensors with advanced detection technology. These include not only the intelligent algorithms for fire detection but also the wide range of different types of detectors, including multisensor detectors OTblue and O²T. ES Detect also helps to save costs, because with the implemented drift compensation, ES Detect can be operated a full eight years, instead of five years for ordinary detectors, according to DIN 14675. Numerous accessories are available from the program of the IQ8Quad detector series. The ES Detect is equipped with a logo for optical differentiation. The convenient maintenance with the programming software tools 8000 (in preparation) completes the full spectrum of ES Detect, from which the operating data of the detector (for example, the measured values, contamination, alarm counters, operating hours counter ...) can be read and stored. The detectors remain where they were installed, because the complete detector group can be connected to a PC and serviced via the field bus interface (Part No. 789862.10).

Technical Data

Operating voltage	8 ... 42 V DC
Alarm current @ 9 V DC	typ. 9 mA
Air speed	0 ... 25.4 m/s
Storage temperature	-25 °C ... 75 °C
Air humidity	< 95 % (non-condensing)
Type of protection	IP 43 (base + option)
Material	ABS
Color	white, similar to RAL 9010
Weight	approx. 110 g
Dimensions	Ø: 117 mm H: 49 mm (62 mm inkl. Sockel)



Special colors on request!

In order to pass through existing wires, the WAGO grips (e.g., type 243-204 (Ø 0.5-1 mm) or 273/104 (0.75-2.5 mm²)), can be integrated into the detector base.



Detector base is not supplied as standard

Accessories

- 767800 assembly bracket
- 805590 standard IQ8Quad detector base
- 805591 detector base with IQ8Quad relay contact

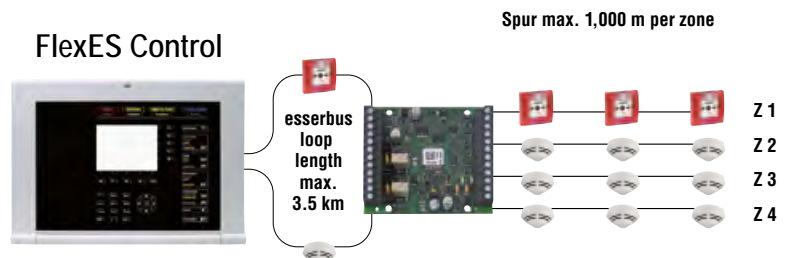

800171

Fixed heat detector ES Detect

Approval: G 213068

Automatic heat detector with fast semiconductor sensor for reliable detection of fires with distinctive heat. Fire detector with decentralized intelligence, automatic function self-test, alarm and operations data storage and alarm display. A remote indicator can also be connected.

Technical Data

Quiescent current @ 9 V DC	approx. 25 μ A
Area to be monitored	max. 30 m ²
Height to be monitored	max. 7.5 m
Application temperature	-20 °C ... 50 °C
Detector specification	EN 54-5 A1S

 Special marking for heat detector on the light pipe: black ring

800177

Fixed heat detector ES Detect, Class B

Approval: G 213067

As 800171, however, for increased response temperature according to EN 54-5 class B.

Technical Data

Quiescent current @ 9 V DC	approx. 25 μ A
Area to be monitored	max. 30 m ²
Height to be monitored	max. 6 m
Application temperature	-20 °C ... 65 °C
Detector specification	EN 54-5 BS

 Special marking for heat detector on the light pipe: black ring

800271

Rate-of-rise detector ES Detect

Approval: G 213069

Automatic heat detector with fast semiconductor sensor for reliable detection of fires with rapid temperature rise and integrated maximum value function for the recognition of fires with slow temperature rises. Fire detector with decentralized intelligence, automatic function self-test, alarm and operations data storage and alarm display. A remote indicator can also be connected.

Technical Data

Quiescent current @ 9 V DC	approx. 25 μ A
Area to be monitored	max. 30 m ²
Height to be monitored	max. 7.5 m
Application temperature	-20 °C ... 50 °C
Detector specification	EN 54-5 A1R

 Special marking for heat detector on the light pipe: black ring

800371

Optical smoke detector ES Detect

Approval: G 213066

Scattered-light smoke detector for reliable early detection of fires. Fire detector with decentralized intelligence, automatic function self-test, automatic environmental adaptation, alarm and operating data storage and alarm display.

A remote indicator can also be connected.

Technical Data

Quiescent current @ 9 V DC	approx. 30 μ A
Area to be monitored	max. 110 m ²
Height to be monitored	max. 12 m
Application temperature	-20 °C ... 72 °C
Detector specification	EN 54-7

800375

OT^{blue} multisensor detector ES Detect

Approval: G 213065

Multisensor detector with integrated optical smoke and heat sensor. The optical measurement chamber is equipped with a novel sensor which allows the detection of open fires, smoldering fires and fires with high heat.

The classical ionization detector is replaced by these detection methods, especially in open fires.

This detector is also capable of detecting test fires TF1 and TF6 described in the EN 54-9:1982.

The OT^{blue} multisensor is a fire detector with temporal signal analysis, weighted combination of

sensor data, decentralized intelligence, automatic function self-test, automatic environmental

adaptation, alarm and operating data storage and alarm display.

A remote indicator can also be connected.

Technical Data

Quiescent current @ 9 V DC	approx. 35 μ A
Area to be monitored	max. 110 m ²
Height to be monitored	max. 12 m
Application temperature	-20 °C ... 50 °C
Detector specification	EN 54-7/-5 A2, CEA 4021

800374

O²T multisensor detector ES Detect

Approval: G 213070

Multisensor detector with two integrated optical smoke sensors with different scattered light angles as well as additional heat detector sensor evaluation for detecting anything from smoldering fires to open fires with uniform response characteristics. Compares smoke sensor signals for smoke classification and reduction of false alarms from water vapor or dust, for example. Due to its excellent detection properties, the detector is also capable recognizing test fires TF1 and TF6 described in the standard. The O²T multisensor detector is also suitable for higher application temperatures of up to +65° C.

A remote indicator can also be connected.

Technical Data

Quiescent current @ 9 V DC	approx. 45 μ A
Area to be monitored	max. 110 m ²
Height to be monitored	max. 12 m
Application temperature	-20 °C ... 65 °C
Detector specification	EN 54-7/-5 B, CEA 4021

800361.10

**Optical Smoke Detector Detect ES with relay contact, 48 V DC operation**

The threshold value detector with relay contact 800361.10 comprises an optical smoke detector 800371 from the ES Detect series and a detector base 805592 which enables a direct connection to a 48 V DC power supply. The detector therefore does not need to be operated in connection with a fire alarm control panel.

If the detector detects a fire alarm, a floating relay contact activates to transmit the alarm. The relay contact is normally open (NO) by default, but can also be configured as normally closed (NC) with a solder strap on the circuit board base.

A typical use for this detector is to monitor mobile communication stations, e.g. BTS base transceiver stations.

Take note, the Detector base with relay output for ES Detect 805592 is included in the scope of delivery!

Technical Data

Operating voltage	42 ... 58 V DC
Quiescent current	approx. 0.051 mA (@ 48 V DC)
Current consumption	max. 9 mA
Contact load relay	30 V DC / 1A, 60 V DC / 0,45 A
Area to be monitored	max. 110 m ²
Height to be monitored	max. 12 m
Air speed	0 ... 25.4 m/s
Application temperature	-20 °C ... 72 °C
Storage temperature	-25 °C ... 75 °C
Air humidity	< 95 % (non-condensing)
Type of protection	IP 43 (with base and option)
Material	ABS
Color	white, similar to RAL 9010
Weight	approx. 110 g (ca. 190 g incl. base)
Detector specification	EN 54-7
Dimensions	Ø: 117 mm H: 49 mm (incl. base 62 mm)



Replacement for Part No. 761306

805592

**Detector base with relay output for ES Detect 800631.10**

Detector base with relay contact output, for ES Detect detector family. Suitable for 48 V DC operation.

Contact: floating normally open or normally closed, selectable via coding strap, factory setting: normally open.

A typical use for this base with ES Detect detector is to monitor mobile communication stations.

Technical Data

Operating voltage	42 ... 58 V DC
Contact load relay	30 V DC / 1A, 60 V DC / 0,45 A
Connection terminal	Ø 0,6 mm ... 2 mm ²
Application temperature	-20 °C ... 72 °C
Storage temperature	-25 °C ... 75 °C
Air humidity	< 95 % (non-condensing)
Material	ABS
Color	white, similar to RAL 9010
Weight	approx. 80 g
Dimensions	Ø: 117 mm H: 24 mm (incl. detector 62 mm)



Cable entry on the side or bottom plate.

For looping existing wires, for example, the type 243-204 WAGO terminals (Ø 0.5 mm Ø 1.0 mm) or 273 to 104 (0.75 mm-2.5 mm) are used.

Not for use with IQ8Quad detectors!

Not for use in esserbus and powered loop ringbus!

Contained in Part No. 800361.10

Replacement for Part No. 781582

Automatic intelligent fire detectors with high reliability and low power consumption used for premises and items of property with medium and high concentration of valuable assets.

Detector series IQ8Quad features, system advantages

- Designed for optimal operation on System 8000 and IQ8Control fire alarm systems
- with multisensor fire detectors for the detection of all types of fires, even under the most difficult operating conditions.
- Detector with and without loop isolator

Different options of installation

- wiring in loop and spur combination, e.g.
- maximum number of detectors with cable lengths of up to 3,500 m with installation cable for fire detection, e.g. cables I-Y(St)Yn x 2 x 0.8 mm
- up to 127 detectors and detector zones per loop installation
- up to 32 detectors per zone

Easy commissioning

- automatic detector addressing
- fixed address assignment of detector location, even after detectors have been replaced or added
- localization of wire breaks and short circuits on loop
- detector-LED used as alarm indicator and as an indicator for detectors in service
- adaptation to changing operating conditions
- dedicated LED for indicating operation (green LED)
- disconnection of individual detectors, detector zones and detection areas
- disconnection of individual sensors or several sensors at once within a multisensor fire detector; either manually or depending on programmed time of the day

Automatic adaptation to varying environmental conditions

- compensation of changing levels of air pressure, humidity, smoke concentration according to the double chamber principle
- electronic compensation of long-term influences like aging or pollution

Reliable detection

- constant alarm sensitivity of multisensor fire detector for all types of fire
- large signal to noise ratio due to the special design of the sensors and the electronics to suppress electromagnetic interference

Reliable false alarm suppression

- high immunity against false alarms by means of timed evaluation of different sensor criteria
- signal patterns not typical for fires are eliminated by using special filter algorithms
- automatic self-monitoring of detector electronics
- continuous loop monitoring even during short-circuits through isolating the relevant segment
- automatic monitoring of all sensors to guarantee operational capacity and correct condition.

Increased operating reliability

- short-circuit and wire break tolerant through monitoring from both ends of the loop
- alarm decision inside detector
- fail-safe circuit activated if communication fails

Maintenance

- automatic maintenance request
- heat detector identification through a black circle on the light transmission plate
- multisensor gas detector identification through a golden loop on the circle transmission plate
- operating time-, alarm- and fault counter in each detector
- automatic, cyclic loop check
- complete status interrogation from the control panel
- interrogation of operating data from all detectors on loop via standard service PC and detector interface

Comprehensive range of accessories

- standard detector base and relay base
- base adapter for ceiling mounting
- dust cover for fire detector or detector base
- kit for suspended ceiling mounting
- RF base

Detectors w/o Integrated Alarm Devices

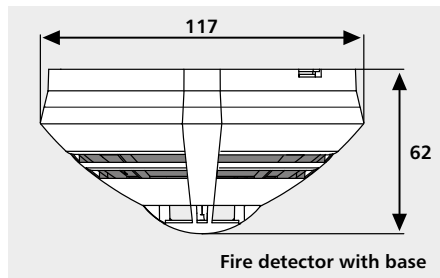
**Technical Data**

Alarm current w/o communication curtain	approx. 18 mA
Air speed	0 ... 25.4 m/s
Storage temperature	-25 °C ... 75 °C
Air humidity	< 95 % (non-condensing)
Type of protection	IP43 (with base + option)
Material	ABS plastic
Color	white, similar to RAL 9010
Weight	approx. 110 g
Dimensions	Ø: 117 mm H: 49 mm (62 mm incl. base)



Special-color on demand

The detectors Part No. 802271, 803271, 802371, 803371, 802373, 802374 and 803374 are approved in the scope of the DIBt system authorization for the operation with an Automatic Door System.



Detector base is not supplied as standard

Accessories

767800 Mounting bracket

805590 Standard detector base for IQ8Quad

805591 Detector base with relay contact for IQ8Quad

802171**Fixed heat detector IQ8Quad with isolator**

Approval: VdS, CNBOP, BOSEC

Automatic heat detector with a single thermistor to sense the air temperature around the detector. Fast semiconductor sensor guarantees reliable detection of fires with strong heat generation. Ideal for sensing in environments that are dirty or smoky under normal conditions, as well it is unaffected by wind or atmospheric pressure. Intelligent fire detector with decentralized intelligence, automatic function self-test, CPU failure mode, alarm and operating data memory, alarm indicator, soft-addressing and operating indication. The detector is provided with an integrated isolator. A parallel detector indicator can be connected.

Technical Data

Operating voltage	8 ... 42 V DC
Quiescent current @ 19 V DC	approx. 40 µA approx. 220 µA @ 42 V
Area to be monitored	max. 30 m ²
Height to be monitored	max. 7.5 m
Application temperature	-20 °C ... 50 °C
Detector specification	EN 54 - 5 A1S / -17
Declaration of Performance	DoP-20102130701



Special marking for heat detector on the light pipe: black ring.

802177**Fixed heat detector IQ8Quad (class B), with higher operating temperature with isolator**

Approval: VdS

Same as 802171, but for increased operating temperature according to EN 54-5 class B.

Technical Data

Operating voltage	8 ... 42 V DC
Quiescent current @ 19 V DC	approx. 40 µA approx. 220 µA @ 42 V
Area to be monitored	max. 30 m ²
Height to be monitored	max. 6 m
Application temperature	-20 °C ... 65 °C
Detector specification	EN 54-5 BS / -17
Declaration of Performance	DoP-20411130701



Special marking for heat detector on the light pipe: black ring.

802271

Rate-of-rise heat detector IQ8Quad with isolator

Approval: VdS, CNBOP, BOSEC

Automatic heat detector with a single thermistor to sense the air temperature around the detector. Fast semiconductor sensor guarantees reliable detection of fires with rapidly rising temperatures and integrated fixed temperature function for the detection of fires with slowly rising temperatures. Ideal for sensing in environments that are dirty or smoky under normal conditions, as well it is unaffected by wind or atmospheric pressure. Intelligent fire detector with decentralized intelligence, automatic function self-test, CPU failure mode, alarm and operating data memory, alarm indicator, soft-addressing and operating indication. The detector is provided with an integrated isolator. A parallel detector indicator can be connected.

Technical Data

Operating voltage	8 ... 42 V DC
Quiescent current @ 19 V DC	approx. 40 μ A approx. 220 μ A @ 42 V
Area to be monitored	max. 30 m ²
Height to be monitored	max. 7.5 m
Application temperature	-20 °C ... 50 °C
Detector specification	EN 54-5 A1 / -17
Declaration of Performance	DoP-20103130701



Special marking for heat detector on the light pipe: black ring.

802371

Optical smoke detector IQ8Quad with isolator

Approval: VdS, CNBOP, BOSEC

Optical smoke detector which works using the light scatter principle to guarantee safe and early detection of fire. Responds well to slow-burning, smouldering fires. Intelligent fire detector with decentralized intelligence, automatic function self-test, CPU failure mode, alarm and operating data memory, alarm indicator, soft-addressing and operating indication. The detector is provided with an integrated isolator. A parallel detector indicator can be connected.

Technical Data

Operating voltage	8 ... 42 V DC
Quiescent current @ 19 V DC	approx. 50 μ A approx. 280 μ A @ 42 V
Area to be monitored	max. 110 m ²
Height to be monitored	max. 12 m
Application temperature	-20 °C ... 72 °C
Detector specification	EN 54-7 / -17
Declaration of Performance	DoP-20104130701

802373

OT multisensor fire detector IQ8Quad with isolator

Approval: VdS

Multisensor fire detector with integrated optical sensor and heat sensor which give both a combined signal as well as a separate heat signal for improved false alarm management, with time-controlled signal analysis and weighted data combination of both detector functions for detecting smouldering fires and fires with extreme heat generation. Intelligent detector with decentralized intelligence, self-function test, CPU redundancy mode, automatic adaptation to the environments, alarm and operating data storage, alarm indication and soft addressing. The loop isolator is integrated in the detector. A parallel detector indicator is additionally attachable.

Technical Data

Operating voltage	9 ... 42 V DC
Quiescent current @ 19 V DC	approx. 50 μ A approx. 280 μ A @ 42 V
Area to be monitored	max. 110 m ²
Height to be monitored	max. 12 m
Application temperature	-20 °C ... 50 °C
Detector specification	EN 54-7/-5 A2 /-17, CEA 4021
Declaration of Performance	DoP-20111130701

802374

O²T multisensor fire detector IQ8Quad with isolator

Approval: VdS, CNBOP, BOSEC

Multisensor fire detector provided with two built-in optical smoke sensors with different scattered light angles as well as additional heat detector sensor evaluation to guarantee the detection of different types of fire from smoldering fires to open fires with constant sensitivity level. Smoke sensor signal identification to ensure smoke classification and reduction of false alarms caused by interferences, for instance, water vapor or dust. Used when early and reliable fire detection is requested. Because of its excellent detection characteristics and enhanced false alarm management, the detector is also able to identify the standardized TF1 and TF6 test fires. The O²T multisensor fire detector is also suitable for applications with higher temperatures of up to +65 °C. The detector is provided with an integrated isolator. A parallel detector indicator can be connected.

Technical Data

Operating voltage	8 ... 42 V DC
Quiescent current @ 19 V DC	approx. 60 µA approx. 330 µA @ 42 V
Area to be monitored	max. 110 m ²
Height to be monitored	max. 12 m
Application temperature	-20 °C ... 65 °C
Detector specification	EN 54-7/-5 B /-17, CEA 4021
Declaration of Performance	DoP-20105130701

802375

OTblue multisensor fire detector IQ8Quad with isolator

Approval: VdS

Multisensor fire detector with integrated optical sensor and heat sensor with enhanced false alarm management. The optical measurement chamber is provided with a patented developed sensor technology using a high-sensitive blue LED (instead of the commonly used red LED in Optical smoke detectors), enabling the detection of open fires, smoldering fires and fires with high heat generation. Especially for open fires, the classical ionization technology implemented in ionization detectors is replaced by the unique detection technology, unlike ionization detectors, this sensor works without a radioactive element which causes problems at the time of refuse disposal. The detector is capable of identifying the TF1 and TF6 test fires described in the EN 54-9:1982 specification. Well suited for sensitive environment, detection of invisible up to large aerosols. The OTblue multisensor is an intelligent detector with time-related signal analysis, signal correlation of the sensor data, decentralized intelligence, automatic function self-test, CPU failure mode, automatic adaptation to environmental conditions, alarm and operating data memory, alarm indicator and soft-addressing.

The detector is provided with an integrated isolator and a parallel detector indicator can be connected.

Technical Data

Operating voltage	9 ... 42 V DC
Quiescent current @ 19 V DC	approx. 50 µA approx. 280 µA @ 42 V
Area to be monitored	max. 110 m ²
Height to be monitored	max. 12 m
Application temperature	-20 °C ... 50 °C
Material	ABS
Detector specification	EN 54-7/-5 A2 /-17, CEA 4021
Declaration of Performance	DoP-20113130701

802473

OTG multisensor fire detector (CO) IQ8Quad with isolator



Approval: VdS

Multisensor fire detector with integrated smoke detector, heat detector and gas sensor (CO) with enhanced false alarm management, for preventive and early detection of deep-seated smouldering fires which give a lot of CO as well as flaming fires through combined evaluation of scattered light, temperature and gas. An alarm is actuated at carbon monoxide (CO) concentration levels that are life-threatening for humans. Less susceptible to false alarms caused by dust, as well earliest and reliable detection of fire development due to the additional detection of CO. Also a Technical Alarm (TAL) can be programmed with the flexible programmable CO threshold up to 150 ppm. The detector is provided with an integrated isolator. A parallel detector indicator can be connected.

Technical Data

Operating voltage	8 ... 42 V DC
Quiescent current @ 19 V DC	approx. 65 µA
Quiescent current @ FACP battery	approx. 225 µA @ 27,5 V approx. 360 µA @ 42 V
CO pre-alarm	approx. 75 ppm
CO alarm	approx. 100 ppm
Area to be monitored	max. 110 m ²
Height to be monitored	max. 12 m
Application temperature	-20 °C ... 50 °C
Detector specification	EN 54-7/-5 A2 /-17, CEA 4021
Declaration of Performance	DoP-20115130701



In the course of installation, we recommend testing the integrated CO sensor with our CO test gas (Part No. 805583) or CO capsule (Part No. 805553).

Durability CO sensor: 5 years

Technical alarm range CO: 10 ppm ... 150 ppm

Gas sensors (CO) mainly react to the carbon monoxide arising from a fire (CO). They have, however, also a cross sensitivity to other gases, as for example hydrogen (H₂), acetylene (C₂H₂) or nitric oxide (NO).

Special marking for gas detector on the light pipe: golden ring.

Detector with Integrated Alarm Devices

Features

Detection

- The reliable O²T multisensor principle for consistent response performance at the highest level of security against false alarms

Flash lamp

- Loop powered - no need for external power supply
- No additional short address
- Automatic synchronization of various IQ8Quad alarm signaling devices
- High flash energy

Sounder

- Loop powered - no need for external power supply
- No additional short address
- Automatic synchronization of various IQ8Quad alarm signaling devices
- Maximum sound level: 92 dB (A) at 1 m
- Maximum sound pressure can be set
- Multiple signal patterns can be combined to one signal
- Signal pattern and repetition rates can be set
- 20 different signal tones, incl. DIN-tone

Speech message with sounder

- Loop powered - no need for external power supply
- No additional short address
- Automatic synchronization of various IQ8Quad alarm signaling devices
- Maximum sound level: 92 dB (A) at 1 m
- Maximum sound pressure can be set
- Multiple signal patterns can be combined to one signal
- Signal pattern and repetition rates can be set
- 20 different signal tones, incl. DIN-tone
- Speech messages can be played in up to 5 languages
- 5 alarm messages per languages are preprogrammed

The IQ8Quad smoke detectors with built-in alarm device incorporate up to 4 different functionalities (detect, flash, sound, and/or speech) depending on the type (O²T/F, O²T/So, O²T/Sp, O²T/FSp) of detector.

- fire detection as per EN 54-7
- integrated heat sensor as per EN 54-5
- optical alarm via flash lamp
- acoustic alarm via sounder as per EN 54-3/A2
- acoustic alarm speech messages as per EN 54-3/A2
- short-circuit isolator as per EN 54-17

Detection

Multisensor detectors with two built-in optical smoke sensors with different scattered light angles as well as additional heat detector sensor evaluation for detecting everything from smouldering fires to open fires with consistent response performance. Smoke sensor signal identification to ensure smoke classification and reduction of false alarms caused, for instance, by water vapor or dust. Each detector is provided with an integrated isolator.

Alarm signaling

The alarm signaling device is activated by the control panel. No further short address needs to be allocated. It is programmed with tools 8000 as of software version 1.05.

Alarm tone / speech message programming

For detectors with speech message and/or alarm tone function with up to five language options, up to 4 signals can be programmed. Two signals are reserved for alarm signaling and evacuation in the case of fire. Two further signals can be programmed for other events. Each signal can consist of up to four signal components, enabling one signal to be programmed as a DIN tone combined with subsequent speech messages in three different languages.

Alarm tones can be chosen from a table with various tone types. For application in schools, a break signal to signify the breaks between class can be activated.

Four different speech messages, each in three languages, are available:

- "An incident has been reported in the building. Please await further instructions."
- "Attention" please. This is an emergency. Please leave the building by the nearest available exit."
- "This is a fire alarm. Please leave the building immediately by the nearest available exit."
- "This is a test message. No action is required. "

When the basic setting is selected, signals / signal components can be continuously repeated until the signalling function is interrupted by the control panel. They can also be programmed with a repetition rate of one to three times. Thus, the break signal in schools can be deliberately set to only one repetition. In the same way, the total signal can be set to continuous repetition, with the DIN tone being played only once while subsequent speech messages are played up to three times.

Sound pressure programming

The sound level [dB (A)] can be set to eight levels, from approximately 64dB (A) to approximately 92dB (A).

All the security you need in one housing with four functions: detection, flasher, sounder and speech alarm.





 All IQ8Quad detectors with built-in alarm devices can only be operated on the powered loop. For physical reasons, an increased sound level leads to a higher current consumption rate of the alarm device, the respective load factor must be considered when calculating the maximum number on the loop. Altogether up to 127 bus devices per loop can still be connected.

Please consider that extra training is required when dealing with IQ8Quad with a built-in alarm device. The training includes installation planning and commissioning techniques. For further information take a look at our training brochure. Information concerning the calculation can be found in the "Project Planning Support" chapter.













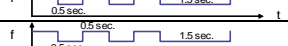

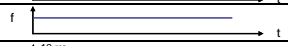

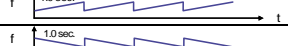
signal 1 (evacuation)	sequence 1	sequence 2	sequence 3	sequence 4
signal 2 (alarm)	sequence 1	sequence 2	sequence 3	sequence 4
signal 3 (event 1)	sequence 1	sequence 2	sequence 3	sequence 4
signal 4 (event 2)	sequence 1	sequence 2	sequence 3	sequence 4

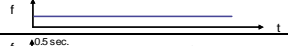
Signals

Detector with Integrated Alarm Devices

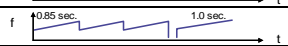
Country code acc. to ISO 3166 -Alpha-2	Language code acc. to ISO 639-1	Evacuation 1	Evacuation 2	Alarm	Test-message	All-Clear
 Germany (DE)	de	Dies ist ein Feueralarm. Bitte verlassen Sie das Gebäude umgehend über die nächsten Fluchtwege. Die Feuerwehr ist alarmiert.	Achtung, Achtung! Dies ist eine Gefahrenmeldung. Bitte verlassen Sie das Gebäude über die nächsten Ausgänge.	Achtung, im Gebäude ist eine Gefahrensituation gemeldet worden. Bitte bleiben Sie ruhig, und warten Sie auf weitere Anweisungen.	Dies ist eine Testdurchsage.	Die Gefahrensituation ist jetzt behoben. Wir entschuldigen uns für jegliche Unannehmlichkeiten.
 Great Britain (GB)	en	This is a fire alarm. Please leave the building immediately by the nearest available exit.	Attention please. This is an emergency. Please leave the building by the nearest available exit.	An incident has been reported in the building. Please await further instructions.	This is a test message. No action is required.	The emergency is now cancelled. We apologize for any inconvenience.
 France (FR)	fr	Ceci est une alarme incendie, veuillez évacuer immédiatement les locaux par la sortie la plus proche.	Votre attention s'il vous plaît, ceci est une alarme. Veuillez évacuer les locaux par la sortie la plus proche.	Un incident est signalé dans le bâtiment. Merci de garder votre calme et attendez les prochaines instructions.	Ceci est un test.	L'alarme est à présent annulée. Veuillez nous excuser pour le désagrément.
 Spain (ES)	es	Esto es una alarma de incendio. Abandonen por favor el edificio inmediatamente por la salida de evacuación más cercana.	Atención. Esto es una emergencia. Por favor abandonen el edificio por la salida de evacuación más cercana.	Atención, se ha reportado un incidente en el edificio. Aguarden por favor otras instrucciones.	Esto es un mensaje de prueba. No se requiere ninguna acción.	La emergencia ha sido cancelada. Pedimos disculpas por las molestias causadas.
 Italy (IT)	it	Attenzione. Allarme incendio. Abbandonare l'edificio tramite l'uscita di emergenza più vicina.	Attenzione. Allarme in corso. Vi preghiamo di recarvi presso l'uscita di emergenza più vicina.	Attenzione. E' stato rilevato un allarme. Ulteriori disposizioni vi verranno comunicate appena possibile.	Attenzione. E' in corso una prova di allarme. Non è richiesta alcuna azione.	Attenzione. Cessato allarme. La situazione di normalità è stata ripristinata.

Standard speech messages of IQ8Quad detectors and IQ8Alarm - for other languages also refer to the appendix!

No.	Description	Frequency	Pulse rate
1	School bell	complex	complex
2	FP 1063.1 Telecoms BS 5839 Pt1	Alternating 800 / 970 Hz at 2 Hz	
3	BS 5839 Pt1	Alternating 800 / 970 Hz at 1 Hz	
4	BS 5839 Pt1	Intermittent 970 Hz at 1 Hz 0.5 sec.	
5	BS 5839 Pt1	Intermittent 2850 Hz at 1 Hz 0.5 sec.	
6	BS 5839 Pt1	Intermittent 970 Hz 1/4 sec. ON - 1 sec. OFF	
7	BS 5839 Pt1	Continuous 970 Hz	
8	BS 5839 Pt1	Sweep tone 800 Hz tp 970 Hz at 7 Hz	
9	BS 5839 Pt1	Sweep tone 800 Hz to 970 Hz at 1 Hz	
10	DIN Tone DIN 33404 Part 3	1200 - 500 Hz at 1 Hz	
11	French fire sound	554 Hz / 100 ms + 440 Hz / 400 ms + 10 %	
12	NL - Slow Whoop	500 Hz - 1200 Hz at 3.5 sec. break of 0.5 sec.	
13	US - Horn	Continuous 485 Hz	
14	US - Horn with Temporal Pattern	Intermittent 485 Hz (0.25 sec. ON; 0.5 sec. OFF; 3 times; 1.5 sec. OFF; Repeat)	
15	US - March Time	Alternating 485 Hz (0.25 sec. ON; 0.25 sec. OFF; Repeat)	
16	US - Slow Whoop	Sweep tone 500 Hz to 1200 Hz (4.0 sec. ON; 0.5 sec. OFF; Repeat)	
17	US - Siren	Sweep tone 600 Hz to 1200 Hz (1.0 sec. ON; Repeat)	
18	US - Hi/Lo	Alternating 100 Hz / 800 Hz (0.25 sec. ON; Alternate; 0.25 sec. ON; Alternate; Repeat)	
19	US - NFPA Whoop	Sweep tone 422 Hz to 775 Hz (upwards sweep 0.85 sec.; 3 times; 1 sec. OFF; Repeat)	
20	IMO GA-Signal	Intermittent 800 Hz (1.0 sec. ON; 1.0 sec. OFF; 7 times; 2.0 sec. ON; 2.0 sec. OFF; Repeat)	

IQ8Quad detectors and IQ8Alarm tone table

Detector with Integrated Alarm Devices

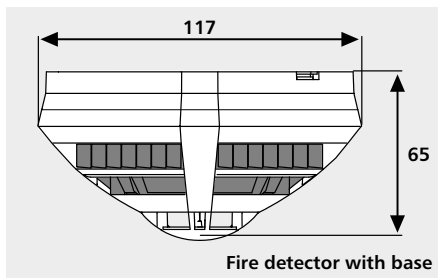
**Technical Data**

Operating voltage	8 ... 42 V DC
Area to be monitored	max. 110 m ²
Height to be monitored	max. 12 m
Air speed	0 ... 25.4 m/s
Application temperature	-20 °C ... 65 °C
Storage temperature	-25 °C ... 75 °C
Air humidity	≤ 95 % (without condensation)
Type of protection	IP 42
Material	ABS plastic
Color	white, similar to RAL 9010
Weight	approx. 145 g
Dimensions	Ø: 117 mm H: 59 mm Ø: 117 mm H: 67 mm (incl. base)



Detector bases are not supplied as standard.

The 769836 demo package is available for presentations. Further data can be viewed in the accessories section for automatic detectors.

Special-colors on demand!

It is not possible to use the detector base with relay (part no. 805591).

When connected with parallel indicator does not allow to program parallel indicator.



Detector base is not supplied as standard

Accessories

767800 Mounting bracket

805590 Standard detector base for IQ8Quad

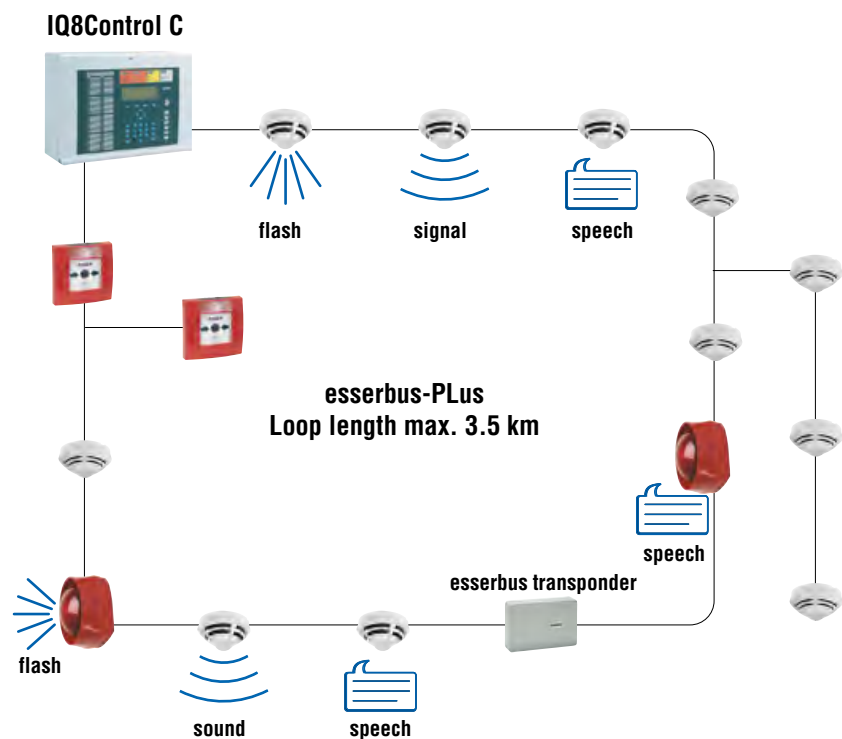

Application example

802382

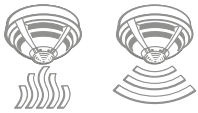
O/So optical smoke detector IQ8Quad**Approval:** VdS

O/So optical smoke detector IQ8Quad with integrated sounder

Scatter smoke detector for safe and early detection of smouldering fires with light smoke generation. Intelligent detector with decentralised intelligence, automatic function self-test, CPU failure mode, alarm and operating data memory, alarm indicator, soft-addressing and operating indication. The detector is provided with a loop isolator.

Along with smoke detection components, the detector is provided with a built-in sounder.

Technical Data

Quiescent current @ 19 V DC	approx. 50 μ A
Load factor	2
Sound level	max. 92 dB (A), +/- 2 db (A) @ 1m for DIN tone
Detector specification	EN 54-7, EN 54-17
Specification	EN 54-3 acoustic signaling device

 Not suitable for application in detector base 805591!

802383

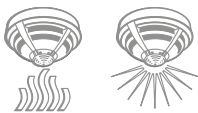
O²T/F multisensor IQ8Quad**Approval:** VdSO²T/F multisensor IQ8Quad with integrated flasher

In addition to smoke detection with the conventional O²T multisensor technology, the detector is provided with a built-in flash lamp.

Technical Data

Quiescent current @ 19 V DC	approx. 75 μ A
Load factor	2
Lighting energy	approx. 3 Y
Strength of light	max. 15,8 cd peak / 2,63 cd effective
Signal flashing lamp	red
Detector specification	EN 54-7/-5 B/-17, CEA 4021

 Not suitable for application in detector base 805591!

802384

O²T/So multisensor IQ8Quad**Approval:** VdSO²T/So multisensor IQ8Quad with integrated sounder

In addition to smoke detection with the conventional O²T multisensor technology, the detector is provided with a built-in alarm signalling device. The sound level can be set to eight different levels.

Technical Data

Quiescent current @ 19 V DC	approx. 80 μ A
Load factor	2
Sound level	max. 92 dB (A), +/- 2 db (A) @ 1m for DIN tone
Type of protection	IP 42
Detector specification	EN 54-7/-5 B/-17, CEA 4021
Specification	EN 54-3 acoustic signaling device

 Not suitable for application in detector base 805591!

802385

O²T/FSp multisensor IQ8Quad

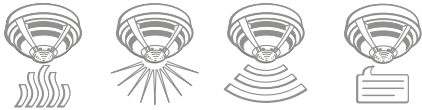

Approval: VdS

O²T/FSp multisensor IQ8Quad with integrated flasher, sounder and speech

In addition to smoke detection with the conventional O²T multisensor technology, the detector is provided with a built-in voice alarm device. It can be set to eight different levels.

Technical Data

Quiescent current @ 19 V DC	approx. 90 µA
Load factor	3
Sound level	max. 92 dB (A), +/- 2 db (A) @ 1m for DIN tone
Lighting energy	approx. 3 Y
Strength of light	max. 15,8 cd peak / 2,63 cd effective
Signal flashing lamp	red
Detector specification	EN 54-7/-5 B/-17, CEA 4021
Specification	EN 54-3 acoustic signaling device EN 54-3 acoustic speech signaling device

Not suitable for application in detector base 805591!

Programmed with 5 standard languages: German, English, Spanish, French and Italian

802385.SV98

O²T/FSp multisensor detector IQ8Quad with composition of other languages

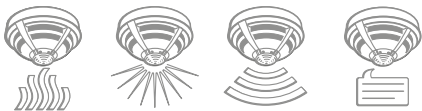

Approval: VdS

O²T/FSp multisensor IQ8Quad with integrated flasher, sounder and speech

As 802385, but with an individual combination of national languages, see special order form in the appendix.

When ordering, please note the "Ordering information for IQ8Quad and IQ8Alarm" and fill in "Order form for individual combination of languages" printed in the appendix.
Cancellations or returns are not possible.
Not suitable for application in detector base 805591!

Programmed with an individual combination of up to 5 languages.

802385.SV99

O²T/FSp multisensor detector IQ8Quad, customized version

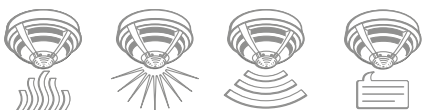

Approval: VdS

O²T/FSp multisensor IQ8Quad with integrated flasher, sounder and speech

As 802385, but with individual text and/or sounds. The max. recording time per device is 169 seconds.

When ordering, please note the "Ordering information for IQ8Quad and IQ8Alarm" and fill in "Order form for individual combination of languages" printed in the appendix.
Costs for the recording of customer-specific texts and/or tones can be obtained by request.
Cancellations or returns are not possible.
Not suitable for application in detector base 805591!

Programmed according to customer specifications.

802386

O²T/Sp multisensor IQ8Quad



Approval: VdS

O²T/Sp multisensor IQ8Quad with integrated sounder and speech

In addition to smoke detection with conventional O²T multisensor technology, the detector is provided with a built-in voice alarm device. It can be set to eight different levels.

Technical Data

Quiescent current @ 19 V DC	approx. 90 µA
Load factor	3
Sound level	max. 92 dB (A), +/- 2 db (A) @ 1m for DIN tone
Detector specification	EN 54-7/-5 B/-17, CEA 4021
Specification	EN 54-3 acoustic signaling device EN 54-3 acoustic speech signaling device

 Not suitable for application in detector base 805591!

 Programmed with 5 standard languages: German, English, Spanish, French and Italian

802386.SV98

O²T/Sp multisensor IQ8Quad, special language



Approval: VdS

As 802386, but special language.

 When ordering, please note the "Ordering information for IQ8Quad and IQ8Alarm" and fill in "Order form for individual combination of languages" printed in the appendix.

 Programmed with individual combination of up to 5 standard languages.

802386.SV99

O²T/Sp multisensor IQ8Quad, customized version



Approval: VdS

As 802386, but with individual text and/or sounds. The max. recording time per device is 169 seconds.

 When ordering, please note the "Ordering information for IQ8Quad and IQ8Alarm" and fill in "Order form for individual combination of languages" printed in the appendix.

Series IQ8Quad Ex (i)

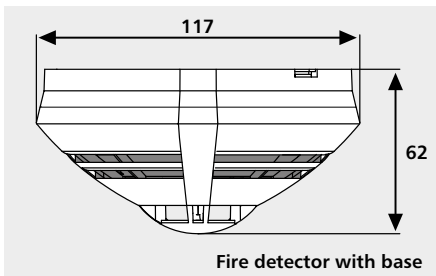

Technical Data

Data according to ATEX:

Max. Input Voltage (U_i)	21 V DC
Max. Input current (I_i)	252 mA
Max. Output current (I_o)	10 mA
Max. internal capacity (C_i)	1 nF
Ambient temperature (T_a)	-20 °C ... 70 °C
EC-type examination certificate	TUV 09 ATEX 554910
Ex-category	II 2G (with Ex barrier Part No. 804744 or 764744)
Explosion protection	Ex ib IIC T4 Gb

Common technical data:

Operating voltage	8 ... 42 V DC
Alarm current @ 9 V DC	typ. 18 mA
Air speed	0 ... 25.4 m/s
Storage temperature	-25 °C ... 75 °C
Air humidity	< 95 % (non-condensing)
Type of protection	IP 43 (incl. base + option)
Material	ABS
Color	white, similar to RAL 9010
Weight	approx. 110 g
Dimensions	Ø: 117 mm H: 49 mm (62 mm incl. base)

 Detector bases are not supplied as standard.

Fully addressable devices for installation in hazardous areas with direct connection of the Ex barrier (Part No. 804744) on the loop, without spending a loop address for the connection via a transponder as in case of the conventional connection.

Additional detectors for the explosion zones can be found in the chapters manual call points and special detectors. Detailed information about installation and operation can be found in the documentation (Part No. 798920) on our website.

All of the following IQ8Quad intrinsically safe fire detectors must be operated with the Part No. 805590 base. In the case of operation in standard zones, no individual addressing is possible!

For usage in zone 1 and zone 2 in case of operation
 - with individual addressing the Ex barrier Part No. 804744,
 - in conventional zones the Ex barrier Part No. 764744 must be used!

The Ex barrier separates intrinsically safe and non-intrinsically safe circuits before the explosion prone area to be monitored (explosion zone).

Individual addressable operating

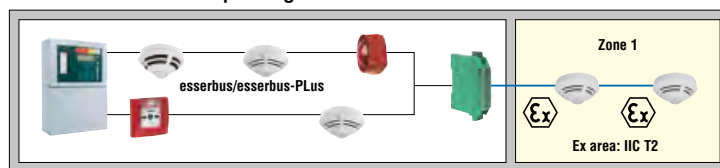

 Ex barrier (Part No. 804744)

Conventional operating

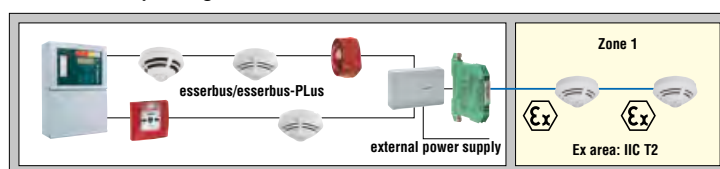

 Ex barrier (Part No. 764744)  esserbus transponder 4 zone / 2 relay

Application example

803271.EX

Rate-of-rise heat detector IQ8Quad Ex (i) w/o isolator**Approval: VdS, ATEX**

Automatic heat detector with a single thermistor to sense the air temperature around the detector. The fast semiconductor sensor for the reliable recognition of fires with a single thermistor to sense the air temperature around the detector. The fast semiconductor quick rate of temperature rise as well as integrated fixed temperature heat function for the recognition of fires with slow temperature rise. Ideal for sensing in environments that are dirty or smoky under normal conditions, as well it is unaffected by wind or atmospheric pressure.

Intelligent fire detector with decentralized intelligence, automatic function self-test, emergency mode, storage of alarm and operating data, alarm display. Soft addressing and separate operational display is only possible when operating an esserbus / esserbus-PLus IQ8Quad detector without loop isolator, especially for usage in explosion zones. Operation with individual addressing at Ex barrier Part No. 804744 and as standard detector at Ex barrier Part No. 764744.

Technical Data

Quiescent current @ 19 V DC	approx. 40 μ A
Area to be monitored	max. 30 m ²
Height to be monitored	max. 7.5 m
Application temperature	-20 °C ... 50 °C
Detector specification	EN 54-5 A1R : 2002



Special marking for heat detector on light pipe: black ring

Accessories

805590 Standard detector base for IQ8Quad

803371.EX

Optical smoke detector IQ8Quad Ex (i) w/o isolator**Approval: VdS, ATEX**

Scattered-light smoke detector for reliable early recognition of fires. Responds well to slow-burning, smouldering fires. Intelligent fire detector with decentralized intelligence, automatic function self-test, emergency mode, storage of alarm and operating data, alarm display. Soft addressing and separate operational display is only possible when operating an esserbus / esserbus-PLus IQ8Quad detector without loop isolator, especially for usage in explosion zones. Operation with individual addressing at Ex barrier Part No. 804744 and as standard detector at Ex barrier Part No. 764744.

Technical Data

Quiescent current @ 19 V DC	approx. 50 μ A
Area to be monitored	max. 110 m ²
Height to be monitored	max. 12 m
Application temperature	-20 °C ... 70 °C
Detector specification	EN 54-7 : 2006
Declaration of Performance	DoP-20914130701

Accessories

805590 Standard detector base for IQ8Quad

803374.EX

O²T multisensor fire detector IQ8Quad Ex (i) w/o isolator

Approval: VdS, ATEX

Intelligent detector with two integrated optical smoke sensors with different scattered-light angles as well as additional heat detector sensor evaluation for the recognition of smoldering fires up to open fires with uniform characteristics. Comparison of the heat sensor signals for smoke classification and reduction of false alarms by interferences, e.g. from steam or dust. Due to its excellent detection characteristics, and enhanced false alarm management, the detector is also able to recognize TF1 and TF6 test fires, described in the standards. The O²T intelligent detector is also suitable for a higher operating temperature of up to +65 °C. Used when early and reliable fire detection is requested. Intelligent fire detector with decentralized intelligence, automatic function self-test, emergency mode, storage of alarm and operating data, alarm display. Soft addressing and separate operational display is only possible when operating an esserbus / esserbus-PLus IQ8Quad detector without loop isolator, especially for usage in explosion zones. Operation with individual addressing at Ex barrier Part No. 804744 and as standard detector at Ex barrier Part No. 764744.

Technical Data

Quiescent current @ 19 V DC	approx. 60 µA
Area to be monitored	max. 110 m ²
Height to be monitored	max. 12 m
Application temperature	-20 °C ... 65 °C
Detector specification	EN 54-7:2006 / -5B:2000 / A1:2002, CEA 4021
Declaration of Performance	DoP-20915130701

Accessories

805590 Standard detector base for IQ8Quad

Accessories for IQ8Quad EX (i)

804744

Ex barrier for intrinsic safe detectors Series IQ8Quad Ex (i)



Approval: ATEX

Ex barrier for the operation of intrinsically safe IQ8Quad Ex (i) series detectors directly on the esserbus/esserbus PPlus with individual addressing in connection with the detector base Part No. 805590.

Technical Data

Ambient temperature	-20 °C ... 60 °C
Air humidity	< 95 % (non-condensing)
Type of protection	IP 20
Weight	approx. 100 g
Specification	EN 54-18:2005
Dimensions	W: 20 mm H: 107 mm D: 115 mm

 A safety barrier does not replace an overvoltage protection according to IEC 801, DIN VDE 0185 and 0855.

You can find more detailed information on the installation and the operation for IQ8Quad Ex (i) Series detectors in the documentation Part No. 798920.

System requirements

- Number of detectors up to max. 10 fire detectors per Ex barrier
- Max. 4 Ex barriers per loop.
- At least one esserbus device with a isolator must be installed between two Ex barriers.
- Total loop length up to max. 3,500 m.
- For each Ex barrier the total loop length must be reduced about 200 meters.
- Cable length (spur) within the Ex area max. 400 m per Ex barrier.
- Load factor 3 per Ex barrier (Use load factor calculation tool).

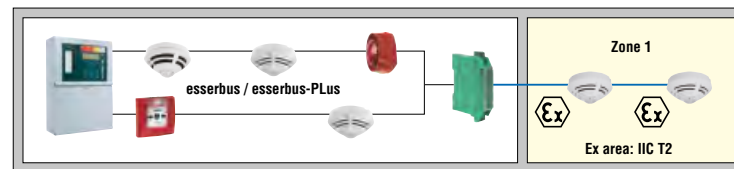
Individual addressable operating

 Ex barrier (Part No. 804744)

Application example

764744

Ex barrier for intrinsic safe detectors Series IQ8Quad Ex (i) and 9100



Approval: ATEX

Ex-barrier for the operation of intrinsically safe IQ8Quad Ex (i) series detectors in connection with the detector base Part No. 805590 as well as the 9100 Ex (i) series in connection with the detector base Part No. 781590.

Technical Data

Ambient temperature (Ta)	-20 °C ... 60 °C
Air humidity	< 95 % (non-condensing)
Dimensions	W: 12.5 mm H: 115 mm D: 110 mm

 A safety barrier does not replace an overvoltage protection according to IEC 801, DIN VDE 0185 and 0855. VdS approval is not required.

You can find more detailed information on the installation and the operation in the documentation Part No. 798920 for IQ8Quad Ex (i) series detectors and Part No. 798913 for 9100 Ex (i) series detectors.

System requirements

- Number of detectors up to max. 8 fire detectors per zone.
- Loop length per zone up to max. 300 m. (Total length measured from the terminals of the detector zone).

Conventional operating

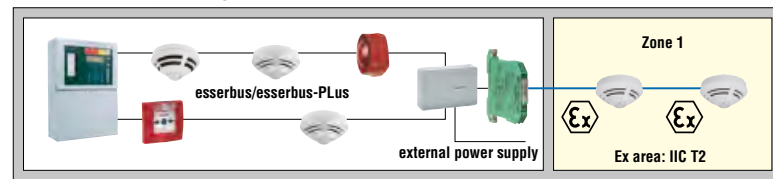

Ex barrier (Part No. 764744)



esserbus transponder 4 zone/2 relay

Application example

764745

Isolation and assembly block for safety Ex barrier

For insulated (earth-free) mounting of Part No. 764744 Ex barrier onto standard hat rail.

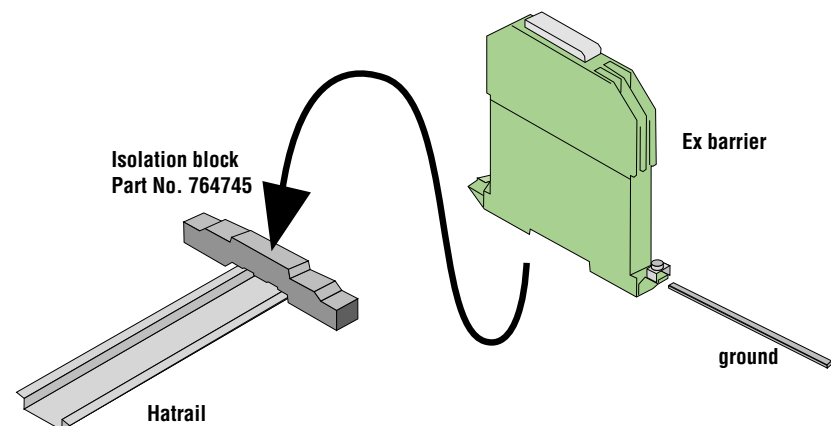

764752**Housing for Ex barrier**

Polyester-housing for the installation of up to max. 10 Ex barriers with integrated inside mounting rail. Also for operational application under extreme environmental conditions suitable.

Technical Data

Type of protection	IP66
Housing	glass-fiber reinforced polyester
Color	gray, similar to RAL 7000
Dimensions	W: 255 mm H: 250 mm D: 160 mm



Mounting material

Features

- Chemically resilient
- Temperature resilient
- Flame retardant
- Non-corrosive
- Sea water resistant
- Non-halogen, UV resistant

764754**Cable gland for housing 764752**

Threaded cable connection for housing Part No. 764752.

Technical Data

Ambient temperature	-20 °C ... 95 °C
Type of protection	IP66
Material	Polyamide
Color	blue, similar to RAL 9005
Cable diameter	8 mm

805590

Standard detector base for IQ8Quad



Features

- A lot of space for wire connection
- Automatic closing of the loop bus wiring system for detector extraction
- Detector extraction locking is enclosed in the base

Technical Data

Connection terminal	Ø 0.6 mm to 2 mm ²
Application temperature	-20 °C ... 72 °C
Storage temperature	-25 °C ... 75 °C
Material	ABS
Color	white, similar to RAL 9010
Weight	approx. 60 g
Dimensions	Ø: 117 mm H: 24 mm (incl. detector 62 mm)



Cable entry on the side or through the bottom plate.

Wago clamps for looping in wires, e.g. type 243-204 (Ø 0.5 mm - Ø 1.0 mm) or 273-104 (0.75 mm² - 2.5 mm²) can be mounted on the detector base.

805591

Detector base with relay contact for IQ8Quad



Features

- Provides a voltage-free contact controlled by the remote output of a detector
- Draws negligible current
- A lot of space for wire connection
- Automatic closing of the loop bus wiring system for detector extraction
- Detector extraction locking is enclosed in the base

IQ8Quad detector base with relay contact output. Contact: floating NO or NC contact selectable via jumper. Settings on site: NO contact.

Technical Data

Current consumption	5 µA (w/o detector, active relay)
Contact load relay	30 V DC/1 A
Connection terminal	Ø 0.6 mm to 2 mm ²
Application temperature	-20 °C ... 72 °C
Storage temperature	-25 °C ... 75 °C
Air humidity	< 95 % (non-condensing)
Material	ABS
Color	white, similar to RAL 9010
Weight	approx. 80 g
Dimensions	Ø: 117 mm H: 24 mm (incl. detector 62 mm)



Cable entry on the side or through the bottom plate. Connection of remote indicators not allowed!

Wago clamps for looping in wires, e.g. type 243-204 (Ø 0.5 mm - 1.0 mm) or 273-104 (0.75 mm² - 2.5 mm²) can be mounted on the detector base.

Not suitable for application with IQ8Quad with integrated alarm device Part No. 802383, 802384, 802385 and 802386 as well as 802385.SVxx and 802386.SVxx!

Accessories for Series IQ8Quad, ES Detect

805588

Detector cover for IQ8Quad w/o built-in alarm sounder



The cover plate protects the IQ8Quad detector against contamination during construction or renovation works.

 The detector covers can only be used for IQ8Quad fire detectors without built-in alarm sounder! Application only for detector types with Part No: 802171, 802271, 802371, 802374, 802375 and 802473.

 50 pcs

805587

Base cover for IQ8Quad



The cover plate protects the IQ8Quad detector base against contamination during construction or renovation works.

 50 pcs

805589

Detector cover for IQ8Quad with built-in alarm sounder



The cover plate protects the IQ8Quad detector against contamination during construction or renovation works.

 The detector covers can only be used for IQ8Quad fire detectors with built-in alarm sounder! Application only for detector types with Part No: 802283, 802384, 802386 and 802385.

 50 pcs

805571

Flush mount kit for base IQ8Quad



Adapter for installation in ceilings and for mounting the detector bases IQ8Quad (Part No. 805590 and 805591) to the bottom side of false ceilings.

Technical Data

Application temperature	-20 °C ... 72 °C
Storage temperature	-25 °C ... 75 °C
Air humidity	< 95 % (non-condensing)
Type of protection	IP 40
Material	ABS, plastic
Color	white, similar to RAL 9010
Weight	approx. 165 g (with surface ring)

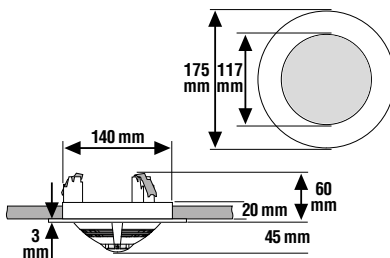

Application example

805574

4" trim ring and snap-in mounting clips for IQ8Quad detector base

Snap-in mounting clips and trim ring for base installation, e.g. for installation on 4" electrical boxes. Take note, the label plate Part No. 805576 is not applicable.

Technical Data

Material	ABS plastic
Color	white, similar to RAL 9010
Dimensions	Ø: 155 mm H: 19 mm (outside)



1 x Trim ring and 2 x snap-in mounting clips



Application example

805576

Label plate for detector base IQ8Quad

Before or after the installation of the detector, the label plate can be inserted at the side slot of the IQ8Quad detector base.



For identification purposes the detector can be provided with the detector address and detector zone for ceilings with a maximum height of 3 m.

A label can be attached to the inscription field. Blank labels can be marked when using a PC, e.g. SIGEL Part No. LP725-white (58 x 18 mm) or other suppliers of writing materials.

There is a help file in the download area for creating the printing material.

Applicable for base 1x Part No. 805590/91 with 805570; for 805593.10, 805594.10.

Not to be used for base 1x Part No. 805590/91 in combination with 805571, 805572, 805573, 805574.



10 pcs



Application example

259529

IQ8Quad and ES Detect detector heating element**NEW****Features**

- Raises the detector temperature by 15°C
- Heating element for use in cold areas or objects with large temperature fluctuations
- Fits both IQ8 and 9200 detector bases
- To be used with external thermostat or deep base

Heating element for use in cold areas or objects with large temperature fluctuations. The element should be used in connection with a deep/weather proof base. The dimensions of the element allows it to be used with any base having 60 mm fixing distance. External thermostat must be used if the surrounding temperature can exceed 25°C. The power can be either AC or DC, but must not exceed 25 V.

Technical Data

Color	white, similar to RAL 9010
Dimensions	Ø: 117 mm H: 3 mm

805577

**Mounting adapter for intermediate ceilings**

The mounting adapter is used for the quick and secure attachment of bases of the IQ8Quad detector series, 9x00, IQ8Alarm and alarm signaling devices, parallel detector indicators, etc. to suspended ceiling systems. It saves the usage of special hollow cavity fasteners, since the mounting screws of the bases are screwed directly into the slots of the mounting adapter. The mounting adapter offers additional advantages in the fixing of the cables, rigid/flexible cable inlays and threaded cable connections.

Technical Data

Material	ABS
----------	-----

 10 pieces

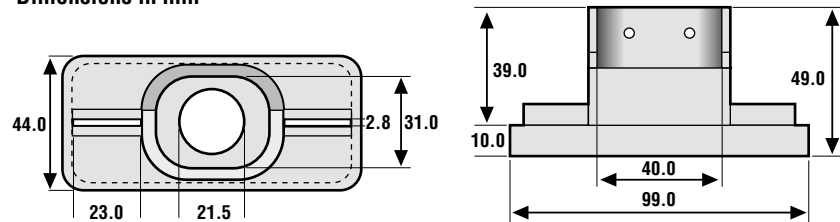
Dimensions in mm

Application examples for fixing of the cables, rigid/flexible cable inlays and threaded cable connections

805570

**IP42 protection for detector base IQ8Quad, flat design**

For installation in environments with dust and humidity. The IP protection protects the IQ8Quad detector base against dust and humidity. It increases the protection level to IP42. For easy mounting to the base, the IP protection is provided with an adhesive film.

Technical Data

Type of protection	IP42
Material	SBR/NR
Color	white, similar to RAL 9010
Dimensions	Ø: 117 mm H: 3 mm

 10 pcs

805572.50

IP43 damp room base adapter for IQ8Quad, ES Detect detector base

The damp room socket adapter was designed specifically for the surface mounted cable feed through cable protection pipes and has three breakthrough inputs for cable glands (optional). Suitable for IQ8Quad and ES Detect detector base.

Technical Data

Type of protection	IP43
Material	ABS
Color	white, similar to RAL 9010



Please follow the installation instructions on the adapter!
Substitute for Part No. 805572
Cable glands (Part No. 704147, 704148) are not included.

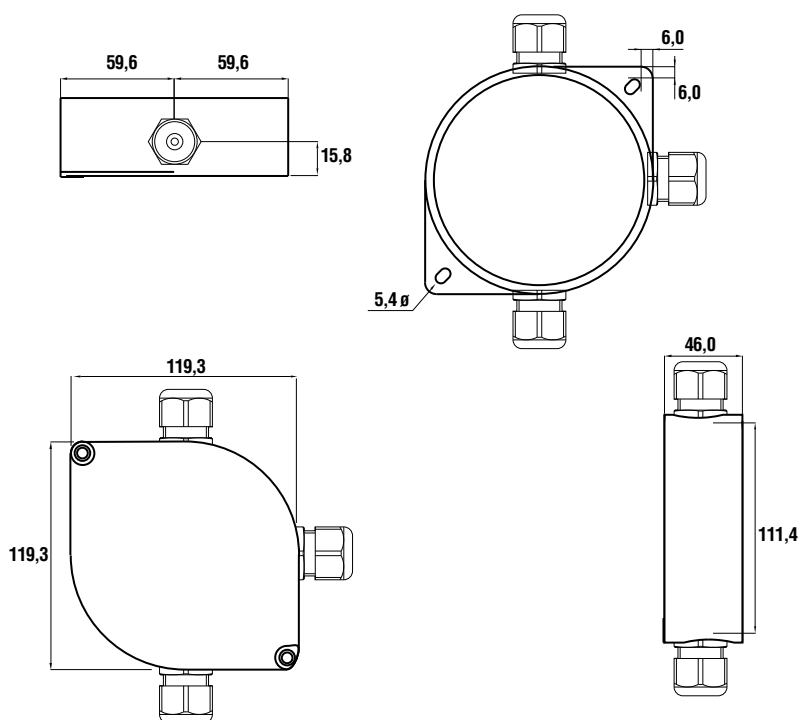

Application example (labeling field and cable glands optional)

805573

IP43 protection for detector base IQ8Quad, deep design

Same as 805570, but as universal protection. Additionally, the seal prevents humidity from entering at the sides.

Technical Data

Type of protection	IP43
Material	rubber
Color	white, similar to RAL 9010



5 pcs

805560

EMV isolator for IQ8Quad, ES Detect detector base



In fire alarm systems where a high electromagnetic interference/EMI load (e.g. by fluorescent lamps or electrical control devices) must be expected it is recommended to mount the EMI-Module in the standard detector base (Part No. 805590) of the corresponding fire alarm detectors.

 The EMI-Module must only be operated in conjunction with standard IQ8Quad detector base (without relay board) and only for detectors without integrated alarm devices (Part No. 802382 to 802386, incl. adapted variants).

 10 pcs



Application example

781482

Kit for suspended installation



Kit for detector bases (Part No. 781590, 805590 and 805591) for suspended installation with pendulum stabilizer, cable entry at the top, pull relief by means of PG cable entry including junction box with terminals. The detector height can be adjusted individually depending on the cable length to bridge over the heat cushion below the ceiling.

Technical Data

Material	ABS plastic
Installation	attached to the zone cable
Color	white, similar to RAL 9010
Dimensions	Ø: 84 mm H: 15 mm (aluminum-stabilizer)

 It is not possible to use telescopic rods.
Not suitable for series 3000.

 As shown in the left picture

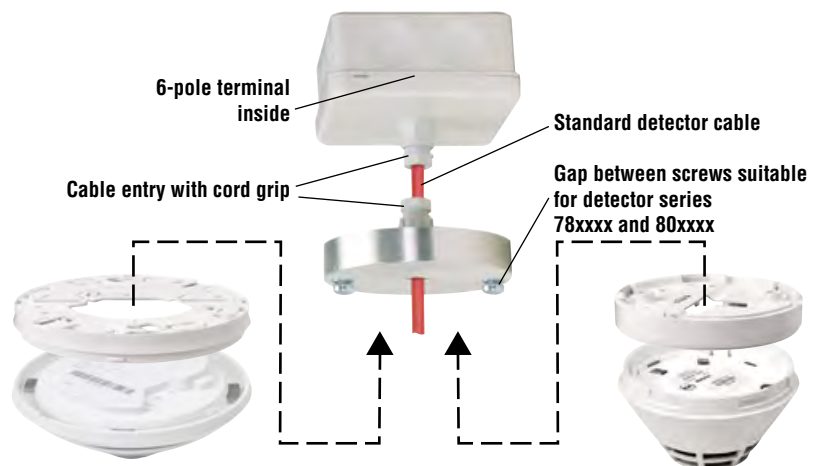

Detector base can be equipped with IP protection 805570 or 805573

781550

**Protective cage**

Protective cage for detectors
Steel basket for protection from damage and also unauthorized disconnection of the detector.

Technical Data

Material	steel with paint coating
Color	white, similar to RAL 9010
Dimensions	Ø: 140 mm H: 115 mm

 Can be used with all bases, IP43 moisture-proof adapter, also for wireless base and wireless gateway.



Application example with IQ8Wireless detector base and IQ8Alarm

850054

Special painting IQ8Quad detector base

The IQ8 detector base is painted and delivered according to the required RAL color.
For identical colors, we suggest to order a suitable number for serial purposes.

 When ordering please specify:
- RAL code
- Glossy, semi-matt, matt finishing

850055

Special painting IQ8Quad

As 850054, but for automatic detectors of the IQ8Quad series.

Testequipment for Several Detector Series

805580

Detector removal tool



It is suitable for removing series 9x00 as well as IQ8Quad detectors. Through optional adaptation of the suction cup to the corresponding insert on the detector removal tool, the IQ8Quad detector covers (Part No. 805588 and 805589) and the base covers for IQ8Quad (Part No. 805587) can be attached as well as removed. The detector removal tool can be adapted to the telescope rod Part No. 060426 and 060427 as well as with Part No. 805581 to 769813.

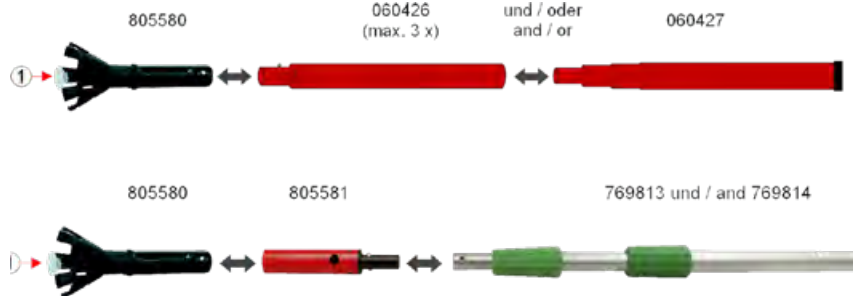
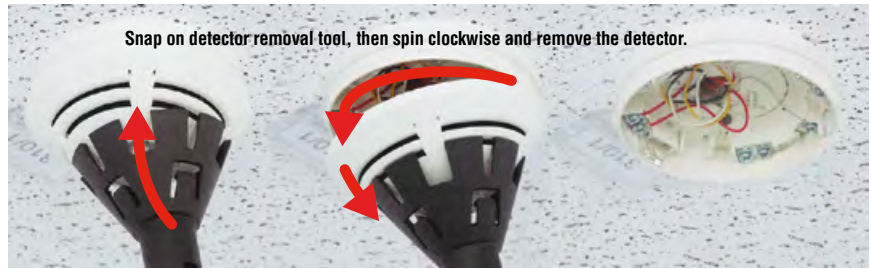

Application example

805581

Adapter for pole 769813



The adapter for the pole (Part No. 769813) is designed for attaching the Part No. 805580 detector removal tool and the Part No. 805582 smoke detector tester.

060426

Plastic telescopic extension



Telescopic extension for plastic telescopic rod (Part No. 060427). Up to 3 telescopic extensions can be attached to the telescopic rod. The maximum height that can be reached is increased to 9 m.

Technical Data

Material	Fiberglass
Length	1.13 m

Features

- Easy aid for daily maintenance of high ceilings
- Stable construction
- Important for attaching and releasing detectors
- Extremely high level of flexural strength due to fiber-plastic composite material
- Totalock TM for easy and secure locking

060427

Plastic telescopic rod

Extendable detector pull-down pole made of glass-fiber reinforced plastic for adapting the Part No. 805580 detector removal tool as well as testers with Part No. 060429 and 805582.



Technical Data

Material	Fiberglass
Length	4.5 m

Features

- Length of 1.26 m in retracted state
- 4 segments, lockable

805586

Carrying bag for test equipment



The carrying bag has many pockets and compartments in which the ESSER smoke alarm testers, test gas bottles, all cables and other maintenance accessories can be stored. So everything you need for maintenance can always be found in one place. The upholstered, adjustable shoulder strap ensures very easy and comfortable transport. An additional advantage: the bag protects equipment from dirt and moisture.

Technical Data

Dimensions	W: 480 mm H: 420 mm D: 260 mm (carrying bag)
------------	--



1 x Carrying bag and 1 x cover for telescopic rods/extensions

Features

- Exterior lid with Velcro fastening transportation straps for telescopic rod and extensions
- Inside lid with 2 storage compartments for battery backs Part No. 060431
- Inside compartment with up to three optional dividers
- Big front pocket, with up to two optional dividers
- Wide shoulder strap with sliding shoulder pad and additional handles
- Cover with carrying strap for up to 4 telescopic rods Part No. 060427 and/or extensions 060426



Capacity of the protective carrying bag:

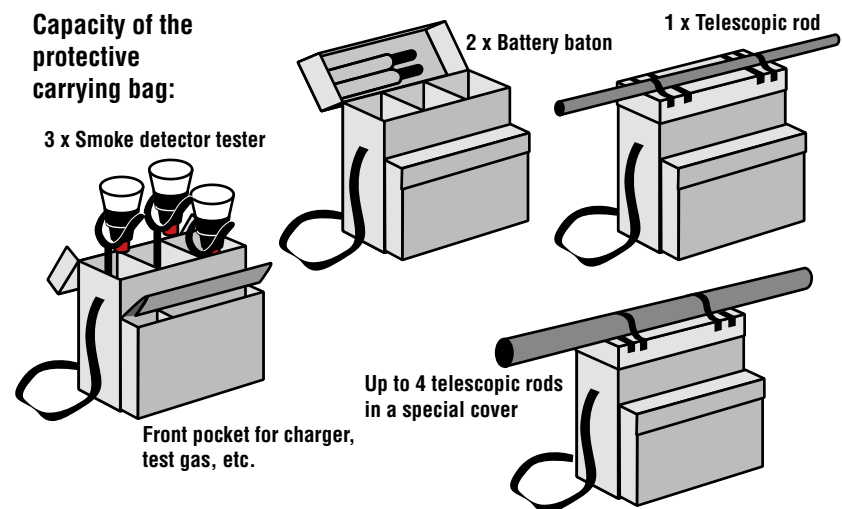

Capacity of the carrying bag

805551

Multi-stimulus detector tester TF 2001



Features

- Generation of smoke, heat and CO in a single test unit
- Clearing cycle of the detector via integrated ventilator for better reset
- Simultaneous or sequential testing with various stimuli
- Suitable for single and multi-criteria fire detectors
- Suitable for smoke-, heat- and gas- (CO) detectors
- Targeted heat rays provide fast activation of heat sensors (up to 90°C/194°F, and/or adjustable up to 100°C/212°F)
- Test activation via infrared barrier, no mechanical triggering, no ceiling contact necessary
- Easy, fast and efficient testing, as changing of testing device is not necessary
- Multilingual and user-friendly menu control: English, German, Spanish, French, Italian, Dutch, Swedish
- Battery operated portable device
- Environmentally friendly and safe through usage of test cartridges instead of test gas cans

Detector tester kit Testifire 2001 for the functional testing of point-type fire detectors with various sensors. The activating stimuli for smoke, heat and CO (carbon monoxide) are generated in this testing unit. Thus the changing of test tools for different types of detectors is no longer necessary. All fire detector types can be tested with only one test instrument. The test tool is suitable for all optical smoke detectors, ionization detectors, CO detectors and heat detectors. It facilitates fast and effective testing of single and intelligent multisensor fire detectors. So testing of the different sensors can be carried out one after another or for all at the same time.

The required stimuli are generated on demand at the time of test from the corresponding capsule (smoke or CO). Pressurized gas cans are no longer being used.

The selection of the testing stimuli, as well as their combination and sequence are menu driven via keypad and are represented on the display (multilingual). So e.g. simultaneous or sequential testing, or also a combination thereof, can be easily programmed and then carried out at the detector. The activation of the testing device occurs automatically, as soon as the detector interrupts the light barrier integrated in the device. If necessary, a clearing phase can be chosen between the specific testing criteria that enables the stimuli to be blown out of the detector immediately for the next test by the integrated ventilator.

The currently active criterion is represented by a multi-colored LED indicator and is clearly recognizable even from large distances. The fill-level of the respective test resource capsules can be shown in the display. Warnings are indicated automatically e.g. if a capsule is nearly empty. The capsules offer much higher test capacities in comparison with aerosol cans.

The power supply of the testing head occurs via Ni-MH batteries (metal hydride batteries) in the adapter between testing head and telescopic rod. Charging of the battery occurs with the charger optionally via adapter (100-230 V AC) or via 12 V DC input (vehicle cigarette lighter).

Suitable for IQ8Quad and 9x00 detector series.

Technical Data

Battery charging	75-90 minutes
Heat detector response threshold	up to 90°C adjustable up to 100°C
Ambient temperature	5 °C ... 45 °C
Storage temperature	-10 °C ... 50 °C
Air humidity	< 85 % (non-condensing)



Detector tester kit Testifire 2001 consists of:
Testing head, smoke capsule, CO capsule, 2 Ni-MH battery packs, charger

Accessories

- 805552 Smoke capsule for multi-stimulus detector tester 805550/51
- 805553 CO capsule for multi-stimulus detector tester 805551 (Testifire TC3)
- 060426 Plastic telescopic extension
- 060427 Plastic telescopic rod
- 060431 Spare battery baton

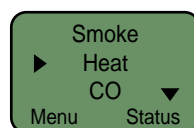

Example of testing with only one stimuli

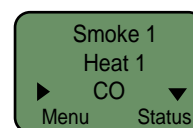

Example of a simultaneous testing (smoke + heat at the same time)

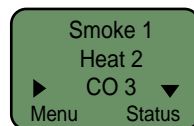

Example of sequential testing (all criteria successively)

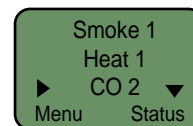

Example of combination of simultaneous and sequential testing

Selection of different test criteria displayed

805550

Features

- Creation of smoke and heat with one single test device
- Desmoking of detector via an integrated fan for fast resetting
- Simultaneous or successive testing with different activating materials
- Suitable for single and multi-criteria detectors
- Suitable for smoke and heat detectors
- Targeted heat radiation facilitates quick activation of the thermal sensors (up to 90°C/194°F and/or can be switched up to 100°C/212°F)
- Test activation through infrared barrier, no mechanical triggering, ceiling contact not necessary
- Quick, easy and efficient testing since there is no need to exchange test device
- Multilingual and user-friendly menu
- Portable battery-powered device
- Environmentally friendly and safe through usage of test cartridges instead of test gas cans

Multi-stimulus detector tester TF 1001

Same as 805551, but for testing of detectors with smoke and heat sensors. For testing CO consider multi-stimulus detector tester TF 2001 (Part No. 805551).

Technical Data

Battery charging	75-90 minutes
Heat detector response threshold	up to 90°C adjustable up to 100°C
Application temperature	5 °C ... 45 °C
Storage temperature	-10 °C ... 50 °C
Air humidity	< 85 % (non-condensing)

 Detector tester kit TF 1001 consists of:
Testing head, smoke capsule, 2 Ni-MH battery packs, charger

Accessories

- 805552 Smoke capsule for multi-stimulus detector tester 805550/51
- 060426 Plastic telescopic extension
- 060427 Plastic telescopic rod
- 060431 Spare battery baton

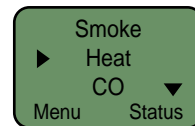

Example of testing with only one stimuli

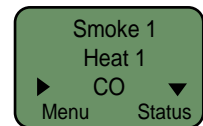

Example of a simultaneous testing (smoke + heat at the same time)

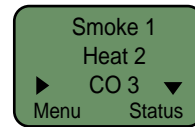

Example of sequential testing (all criteria successively)

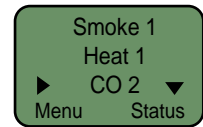

Example of combination of simultaneous and sequential testing)

Selection of different test criteria displayed

805552



Features

- Non-flammable, non-toxic materials
- Production of test gas only during the testing
- Does not cause any residue in the sensor chamber
- Suitable for optical and ionization detectors
- No test gas storage under pressure – no dangerous goods
- More productivity than the spray can

Smoke capsule for multi-stimulus detector tester 805550/51

Replacement smoke capsule (Testfire TS3) for the testing of smoke detectors series IQ8Quad and 9x00 with optical and/or ionization sensors. Suitable for the multi-stimulus detector tester Part No. 805550/51.

805553

**Features**

- Non-flammable CO activating material
- Generation of small amounts of CO
- Generation of CO during testing only
- No storing of pressurized CO - no dangerous goods
- More productivity than the spray can

CO capsule for multi-stimulus detector tester 805551

Replacement CO capsule (Testifire TC3) for the testing of detectors with carbon monoxide sensors (CO). Especially suited for the OTG multisensor fire detector (CO) IQ8Quad with isolator (Part No. 802473). Suitable for the multi-stimulus detector tester Part No. 805551.

-  The OTG multisensor fire detector (CO) IQ8Quad with isolator (Part No. 802473) is generally tested either
- with the test gas Part No. 060430.10, suitable for the smoke detector tester Part No. 805582, or
 - with Part No. 805552, suitable for the multi-stimulus detector tester Part No. 805551.

The Part No. 802473 is VdS-approved as a smoke detector, the CO test gas is required for the additional triggering of the electrochemical CO gas cell.

805582

**Smoke detector tester**

The smoke detector tester is designed for electric function control for the IQ8Quad and series 9x00 detectors. After an aerosol has been released, the operation capacity of the measuring chamber can be tested by using the transceiver. The smoke detector tester is adapted to the rod (Part No. 060427).

-  The telescopic rod is not supplied as standard.

Accessories

- 060426 Plastic telescopic extension
060427 Plastic telescopic rod

805583

**CO test gas for smoke detector tester 805582**

Test gas for testing carbon monoxide CO-detectors. Specifically designed for the OTG multisensor fire detector (CO) IQ8Quad with isolator (Part No. 802473), suitable for smoke detector tester Part No. 805582.

Technical Data

Content	250 ml (per bottle)
---------	---------------------

-  The OTG multisensor fire detector (CO) IQ8Quad with isolator (Part No. 802473) should only be tested in connection with test gas Part No. 060430.10 suitable for smoke detector tester Part No. 805582. Detector Part No. 802473 has been approved as smoke detector by VdS and the CO test gas is used to additionally trigger the electrochemical CO-gas cell. Please take note that this item has to be handled as dangerous goods (aerosols, non-flammable, UN1950)

805584

**Test gas for smoke detector tester 805582**

For all IQ8Quad, ES Detect and series 9x00 detectors, suitable for smoke detector tester 805582.

Technical Data

Content	250 ml (per bottle)
---------	---------------------

-  Also suitable for ionization detector of the 9000, 9100 and 9200 series. These are considered dangerous goods (aerosols/gases, flammable, UN1950). Substitute for Item No. 060430.10

805585

Smokesabre test gas for smoke detectors

Smokesabre is a test gas and manual testing device in one. The test gas is passed through the extensible pipe, which also serves to increase the range for the detector. Facilitates the triggering of smoke alarms in confined spaces, such as false ceilings/floors and is also applicable to low ceiling heights.

Suitable for all detectors of the series IQ8Quad, ES Detect, 9x00 and smoke extraction systems.

Technical Data

Content	150 ml (per bottle)
Dimensions	L: 193 mm
	L: 335 mm (with pulled-pipe)



Also suitable for ionization detector of the 9000, 9100 and 9200 series. These are considered dangerous goods (aerosols/gases, flammable, UN1950).



12 pieces



Application example

060429

Test head for heat detector together with battery and charger



Features

- Mains cable is not required for testing
- Power supply with rechargeable NiMH battery in the adapter of the telescopic rod
- Time based termination of testing after 120 seconds in order to prevent any heat-related damages of the detectors
- Detector head is switched off after not being used for 5 minutes
- Adjustable inclination angle of detector head for an optimal orientation towards the object which has to be tested
- Testing height up to 6 meters with telescopic rod and up to 9 meters with its extension device
- Excess-current protection for the battery
- Display of operating status of the detector head with Duo-LED (red/green)
- Battery can be charged via mains supply or via cigarette lighter in vehicles

Technical Data

Battery charging	75-90 minutes (if completely discharged)
Ambient temperature	5 °C ... 45 °C
Storage temperature	-10 °C ... 50 °C
Air humidity	< 85 % (non-condensing)



Test head, 2 battery batons, charger

Accessories

- 060426 Telescopic extension
- 060427 Plastic telescopic rod
- 060431 Spare battery baton

060431.10

Spare battery baton



Replacement battery pack (NiMH) for test head Part No. 060429 and 805551.

251-003

Smoke pellets for testing purposes



Pellets for the generation of dense bright smoke. To charge detectors with smoke for testing purposes and verification of air flow. The pellets are lit with an open flame (e.g. matches, lighter etc.). Extinguishing is not necessary. Please ensure the use of a non-flammable base. After ignition the pellet will burn to complete ash (without formation of flames).



Without oil



6 pcs. smoke pellets

Features

- 40 sec. burning-time per smoke pellet
- 18 m³ smoke produced per smoke pellet

Notes

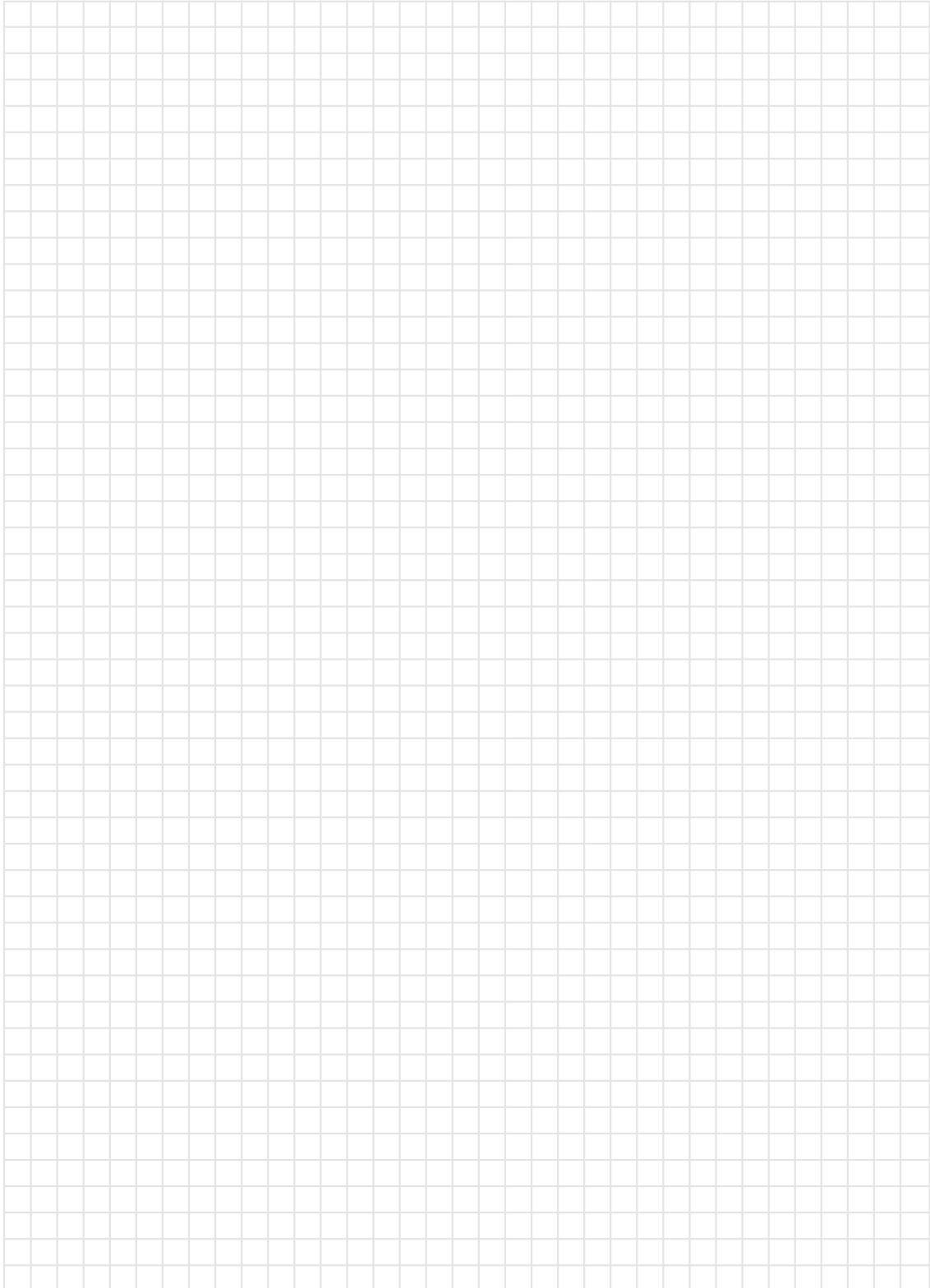



Manual Call Points

Large Design (ABS)	96-99
Accessories for MCP large design	100-103
Small Design (ABS)	104-110
Accessories for MCP small design	111-112
Special Design	113-118

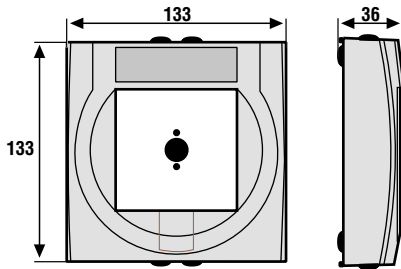

Features

- Slimline design
- Low power consumption
- Plug-in connection clamps
- Optional terminal clamps
- 2 x cable entries on top, at the bottom and on the rear panel
- Fixing on standard flush mounted installation box
- Test function via manual call point service key
- Detectors that are not ready for operation can be marked with the "Out of order" label by reversing the enclosed operating front foil

The advanced generation of manual call points with fragile elements meets the latest multicultural requirements of the EN 54 - 11 standards as type B (double action). The elegant detector housing, available in 5 different RAL colors, is provided with a pictogram, which is easy to comprehend for foreign people, illiterates as well as children.

Depending on individual requirements, optional labeling foils can be used which can easily replace the pictogram without special tools. The triggering element is protected by a pane of glass and is indicated by arrows.

If required, optional labeling foils can be used, which can easily replace the pictogram. The triggering element is protected by a glass pane and is indicated by arrows. The innovative manual call points can be tested by using the service key to activate the triggering mechanism, which is hidden by a faceplate. Clever design structures allow easy installation.

The manual call points consist of a housing and an electronic module, each of the two parts must be ordered separately.

i Type B definition - double action in accordance with EN 54-11 § 3.4.2 (Excerpt taken from EN standard):

Manual fire alarm unit, for which the alarm status cannot be set until an alarm is additionally triggered by the user after the fragile element has been broken or its position, has been changed.

Take note, for a LARGE MCP you have to order the electronic module and the MCP housing separately to have a complete MCP.

Not all possible combinations of electronic modules and housings are approved by VdS.

When using the manual call point as a fire detector for manual actuation in compliance with the EN 54-11 standards, a red housing together with the provided pictogram must be used.

When using the manual call point in heat exhaust or extinguishing system areas, the appropriate housing color must be chosen in compliance with the correct standards.

Wago clamps for looping in wires, e.g. type 273-100 (0.5 mm² - 1.5 mm²) or 273-104 (0.75 mm² - 2.5 mm²) can be mounted on the detector base.



MCP out of order



Easy to maintain the change of condition by turning the operating foil



MCP ready for use

Application example

Plastic Housings



Housings for electronic module 80490x.

Technical Data

Type of protection	IP 44
Housing	ASA plastic
Installation	surface mount
Weight	approx. 83 g (w/o electronic module)
Dimensions	W: 133 mm H: 133 mm D: 36 mm

- Housing with glass pane (Part No. 704910)
- Plastic key (Part No. 769910)

Accessories

- 704910 Spare glass for manual call points
- 769910 Plastic spare key
- 769911 Metal key for large MCP
- 769916 Service key
- 704917 Option IP 55 shrink sleeve for large MCP 80490x
- 704911 Universal foil for large MCP housing ABS

704900

MCP housing large with glass pane, red, similar to RAL 3020

Pictogram according to EN54-11

Technical Data

Dimensions	W: 133 mm H: 133 mm D: 36 mm
------------	------------------------------

- The red manual call point housing is only available with the pictogram (as shown) in compliance with EN 54-11. Please note that in compliance with EN54-11 the labeling must come with the burning house symbol.

704901

MCP housing large with glass pane, blue, similar to RAL 5015

- The Part No. 804902 electronic module in a blue housing complies with the EN 12094-3 and thus can be applied as an electronic stop button for gas extinguishing systems in dry, non-hazardous production sites. For different use such as application as "HOUSE ALARM" push button, ready-made labels are provided.

- Labeling foil set (white) for various international applications.

704902

MCP housing large with glass pane, yellow, similar to RAL 1021

- The Part No. 804900 or 804901 electronic module in a yellow housing 704902 complies with the EN 12094-3 and thus can be applied as electronic control module for gas extinguishing systems in dry, non-hazardous production sites. For different use such as application as "HOUSE ALARM" push button, ready-made labels are available.

- Labeling foil set (black) for various international applications.

704903

MCP housing large with glass pane, orange, similar to RAL 2011

- Labeling foil set (black) for various international applications.

704904

MCP housing large with glass pane, green, similar to RAL 6002

- Labeling foil set (white) for various international applications.

Electronic Modules - Conventional

**Technical Data**

Operating voltage	8 ... 30 V DC
Alarm current @ 9 V DC	typ. 9 mA
No. of detector/zone	10 detectors per zone (according to VdS)
Alarm display	LED, red
Connection terminal	max. 2.5 mm ² (AWG 26-14)
Application temperature	-20 °C ... 70 °C
Storage temperature	-30 °C ... 75 °C
Air humidity	< 95 % (non-condensing)
Type of protection	IP44 (in housing), IP55 (with accessory)
Housing	PC ASA plastic
Weight	approx. 236 g (with housing)
Detector specification	EN 54-11, Type B
Dimensions	W: 133 mm H: 133 mm D: 36 mm

804900

Conventional MCP electronic module

Approval: VdS, CNBOP

With alarm indicator, suitable for connection to a standard detector zone.

**Technical Data**

Declaration of Performance	DoP-20482130701
----------------------------	-----------------

 In combination with the yellow housing (Part No. 704902), the electronic module is approved as an electronic control unit for gas extinguishing systems.

The Part No. 804900 electronic module with yellow housing conforms to the EN 12094-3 standard and can be used as an electronic control unit for gas extinguishing systems in dry, non-hazardous industrial premises.

804901

Conventional MCP electronic module with 2nd microswitch

Approval: VdS, CNBOP

Same as 804900, but with second microswitch with dry contact NC/C (break) or NO/C (make) that is activated when the alarm is triggered.

**Technical Data**

Contact load	30 V DC / 1 A
Declaration of Performance	DoP-20482130701

 In combination with the yellow housing (Part No. 704902), the electronic module is approved as an electronic control unit for gas extinguishing systems.

The Part No. 804901 electronic module with yellow housing conforms to the EN 12094-3 standard and can be used as an electronic control unit for gas extinguishing systems in dry, non-hazardous industrial premises.

804902

Conventional MCP electronic module w/o snap-on function

Approval: VdS with blue housing 704901

Same as 804900, but without snap-on function.

**Technical Data**

Declaration of Performance	DoP-20195130701
----------------------------	-----------------

 This electronic module is only approved as an electric stop push-button for gas extinguishing systems when combined with the blue housing (Part No. 704901). The electronic module Part No. 804902 with blue housing complies with the EN 12094-3 standard and therefore it can be used as an electric stop push-button for gas extinguishing systems in dry, non-hazardous branches.

In case the manual call point is used as a "house alarm" push-button, pre-printed labels are provided in the manual call point package.

Electronic Modules for Series IQ8MCP - Addressable

**Technical Data**

Operating voltage	8 ... 42 V DC
Quiescent current @ 19 V DC	approx. 45 μ A
Alarm current w/o communication curtain	approx. 18 mA
No. of detector/zone	10 detectors per zone, 127 detectors/loop (according to VdS)
Operation indicator	LED, green
Alarm display	LED, red
Connection terminal	max. 2.5 mm ² (AWG 26-14)
Application temperature	-20 °C ... 70 °C
Storage temperature	-30 °C ... 75 °C
Air humidity	< 95 % (non-condensing)
Type of protection	IP 44 (in housing), IP 55 (with accessory)
Housing	PC ASA plastic
Weight	approx. 236 g (in housing)
Detector specification	EN 54-11, type B
Dimensions	W: 133 mm H: 133 mm D: 36 mm

804905

IQ8MCP electronic module with isolator

Approval: VdS, CNBOP

Addressable electronic module suitable for use in the esserbus and powered loop with alarm latch and alarm indicator. Optional connection for conventional MCP. Without BUS connection, the detector operates as conventional MCP. Built-in loop isolator in the manual call point. An external detector zone (D-line) could be connected with up to ten conventional manual call points (internal Alarm resistor for each detector 1 KOhm) - e.g. Part No. 804900 or 804901 to this IQ8 manual call point model and configure required operation with tools 8000. When an alarm is triggered the address and the programmed additional text of the MCP IQ8 to which the conventional zone is connected are displayed automatically. Cable length of the D-line max. 500 meters!

Technical Data

Type of protection	IP44 (in housing), IP55 (with accessory)
Detector specification	EN 54-11, typ B
Declaration of Performance	DoP-20489130701

804906

IQ8MCP electronic module w/o isolator, with relay

Approval: VdS

Addressable electronic module with floating contacts of a changeover relay NC/C (break) or NO/C (make), suitable for use in the esserbus and powered loop with alarm latch and alarm indicator. Without BUS connection, the detector operates as conventional MCP. Without built-in loop isolator and optional connection for conventional MCP.

The relay output is activated with the triggering of this detector. The relay output can be programmed in the System 8000 and IQ8Control FACP customer data as a control group.

Technical Data

Contact load relay	30 V DC / 1 A
Declaration of Performance	DoP-20488130701

704910

Spare glass pane for MCP housing 70490x, 7048xx und 761694



Spare glass pane for detector housings large design Part No. 70490x, 7048xx, 761694 and 761697 in compliance with EN 54-11.

Technical Data

Dimensions W: 80 mm H: 80 mm

 10 pcs

701040

Spare glass pane red for MCP housings 7047xx and 7048xx



Spare glass pane, printed with red circle segments (similar to RAL 3000) for all Part No. 7047xx and Part No. 7048xx manual call points (large design).

Technical Data

Dimensions W: 80 mm H: 80 mm

 10 Multilingual "Out of order" paper labels are included.

 10 pcs

769921

"Out of order" sign, multilingual for 7047xx, 7048xx and 70490x

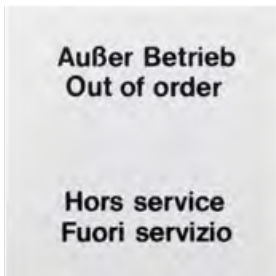

Plastic sign for all Part No. 7047xx, 7048xx and 70490x manual call points (large design).

Technical Data

Dimensions W: 80 mm H: 80 mm

704915

Operating foil for large MCP 80490x, neutral

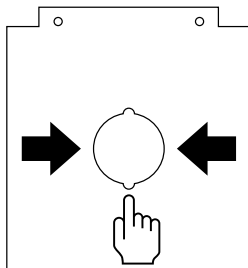

Replacement operating panel foil, neutral without logo, for large design Part No. 80490x manual call points in resistant plastic design. The foil is designed as a double-sided insert. Complementing the standards-compliant symbolism for manual fire alarms according to EN 54-11 (type B), it contains a symbol on the back for the removal from service of the alarm and is easily accessible at all times for possible maintenance operations. The "Out of order" representation occurs via an internationally understandable construction worker symbol and multilingual text.

Technical Data

Material PP (0.3 mm)
Dimensions W: 72 mm H: 75.7 mm

 10 pcs.



MCP "Out of order"



Easy to maintain the change of condition by turning the operating foil.



MCP "Ready for use"

Application example

704917

Option IP55 shrink sleeve for large MCP 80490x

10 shrink sleeves for clamp terminals to increase protection class to IP55.

 10 pcs

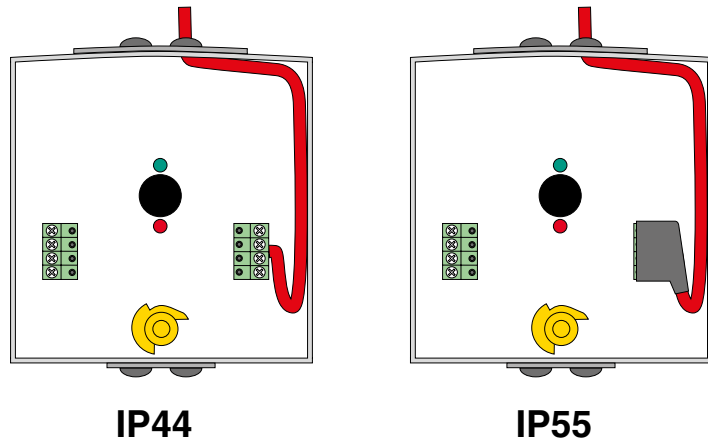

Application example without (IP44) and with (IP55) shrink sleeve

704911

Front foil with universal text for large MCP ABS, white lettering

		Emergency Door Release	AMOK-ALARM
STOPP-TASTER Gaslöschanlage	Arrêt d'urgence extinction	Emergency Stop Gas extinguishing system	
RAUCHABZUG	Arrêt d'urgence Système d'extinction à gaz		
Prüfmelder	PARO EMERGENCIA Sistema de extinción	PARAGEM EMERGENCIA Sistema de extinção	 POZAR
Hausalarm	ONTRUIMING	BLUSSING BLOKKEREN Klop- en rookmelder	 Feuerwehr
Feuerwehr	Fogo	Fire	Fuego

similar image



Universal, punched foil set (transparent with white imprint) for the labeling field, different from the standard version.

 Transparent foil with white lettering.

 10 pcs

704912

Foil for front face with universal text for large MCP ABS, black lettering

		Emergency Door Release	AMOK-ALARM
STOPP-TASTER Gaslöschanlage	Arrêt d'urgence extinction	Emergency Stop Gas extinguishing system	
RAUCHABZUG	Arrêt d'urgence Système d'extinction à gaz		
Prüfmelder	PARO EMERGENCIA Sistema de extinción	PARAGEM EMERGENCIA Sistema de extinção	 POZAR
Hausalarm	ONTRUIMING	BLUSSING BLOKKEREN Klop- en rookmelder	 Feuerwehr
Feuerwehr	Fogo	Fire	Fuego

similar image

As 704911, but with black imprint.

 10 pcs

704070

IP54 kit for large MCP 7048xx



Cable entries to increase protection class from IP 43 to IP 54 for manual call points in die-cast aluminum housings (Part No. 7048xx).

Technical Data

Material	PS
Color	gray, similar to RAL 7035
Cable diameter	6 mm

 as shown

769910

Plastic key for large MCP

Plastic key type D for all manual call points (large design).



 Please note that for activating the test functionality of electronic modules (Part No. 80490x), the service key Part No. 769916 is required.

769911

Metal key for large MCP

Metal key type D for all detector housings (large design).



 Please note that for activating the test functionality of electronic modules (Part No. 80490x), the service key Part No. 769916 is required.

769916

Service key for electronic module (Part No. 80490x)

With this metal service key, the test functionality of the manual call point is activated and reset by authorized persons only.



The key is suitable for all electronic modules with Part No. 80490x from index 05 and yellow locking.

781682

Weather protective cover for MCP housings 7047/48xx, red

Protective housing with protruding roof edge, for all Part No. 7047xx and 7048xx detector housings for increased mechanical protection as well as for protection from bad weather conditions.



Technical Data

Material	PVC
Color	red, similar to RAL 3000
Dimensions	W: 135 mm H: 153 mm D: 62 mm

 Please mention for the manual call point, large design plastic (e.g. IQ8MCP), the protection cover Part No. 781693 and the related accessories.

 Weather protective cover and mounting material

781692

Weather protective cover for MCP housings 7047/48xx, blue

Same as 781682, but blue color.



Technical Data

Color	blue, similar to RAL 5009
-------	---------------------------

 Weather protective cover and mounting material

781693

Protective cover for manual call points, German





Features

- Easy to install

Technical Data

Ambient temperature	-40 °C ... 49 °C
Type of protection	IP 44
Material	Polycarbonate
Weight	approx. 590 g
Dimensions	W: 180 mm H: 260 mm D: 100 mm

 This protective cover prevents false alarms, without hampering real alarms. This device consists of a rack and a lid, made of transparent polycarbonate. It prevents inadvertent activation, vandalism, dust and water from triggering false alarms. The protective cover is suitable for all manual call points.

 Accessory for installation



Application example

781694

Protective cover for manual call points, English

Same as 781693, but English.

781698

Surface spacer for protective cover

The spacer is required for surface mount wiring.



Technical Data

Weight	approx. 510 g
Dimensions	W: 180 mm H: 260 mm D: 50 mm

 Accessory for installation

781699

IP55 kit for protective cover

Mounting kit - self-adhesive sealing kit for protective cover (Part No. 781693, 781694) and an increased protection level from IP 44 to IP 55.

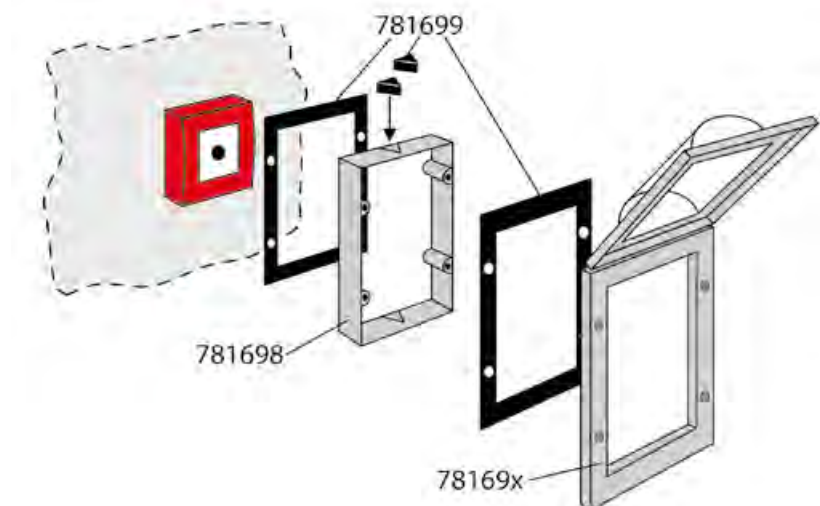

Application example

Small Design (ABS)

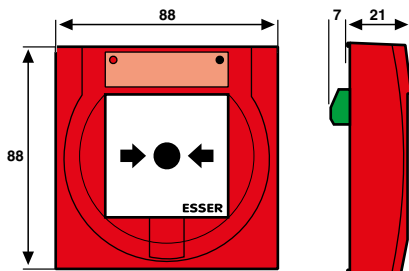

The new generation of manual call points meets the latest multi-cultural requirements of the EN 54 - 11 standards as type A (single action). The elegant housing is provided with a pictogram, which can be understood by children as well as in an international context.

Depending on individual requirements, the pictogram can be easily replaced by optional labeling field foils without using additional tools for removal. The actuation field is marked by arrows pointing towards it. The innovative manual call points can be tested by using the key to activate the triggering mechanism, which is hidden by a faceplate. Smart housing and terminal design enables easy installation.



If the glass pane is replaced with the optionally available plastic pane with reset function, the MCP can be reset from the outside using the key.

For the surface mounting of the MCP the surface mount base Part No. 704980 must be ordered separately, if the cable wasn't laid about a standard flush mount wall socket.

Type a definition - single action in accordance with EN 54-11 § 3.4.1 (excerpt taken from EN standard):

Manual fire alarm unit, for which the alarm status is automatically set (additional alarm triggering is not required) after the fragile element has been broken or its position has been changed.

Features

- Slimline design
- Low power consumption
- Plug-in connection terminals (two direction)
- Optional terminal terminals
- Triple key function (test, open, reset)
- Detectors that are not ready for operation can be marked with the "Out of order" label by reversing the enclosed glass pane

Compact MCP Versions - Conventional

804970

Conventional MCP compact, small, red, glass pane



Approval: VdS, CNBOP

Including housing and alarm indicator. For connection to a conventional detection zone.

Technical Data

Operating voltage	8 ... 30 V DC
Quiescent current @ 9 V DC	approx. 0 µA
Alarm current @ 9 V DC	typ. 9 mA
No. of detector/zone	10 detectors per zone (according to VdS)
Alarm display	red LED and yellow actuation indicator
Connection terminal	max. 2.5 mm ² (AWG 26-14)
Application temperature	-20 °C ... 70 °C
Storage temperature	-30 °C ... 75 °C
Air humidity	< 95 % (non-condensing)
Type of protection	IP43, IP55 with cover 704965
Housing	PC ASA plastic
Color	red, similar to RAL 3020
Weight	approx. 110 g
Detector specification	EN 54-11, type A
Dimensions	W: 88 mm H: 88 mm D: 21 mm
Declaration of Performance	DoP-20486130701



- 1 x Glass pane 704960
- 1 x Key 704966
- 1 x Multilingual paper labels with "Out of order" pictogram.

Accessories

704980 Surface mount housing

804971

IQ8MCP compact, small, red, with isolator and glass pane



Approval: VdS, CNBOP

Suitable for esserbus and powered loop connection, with soft address coding, alarm latch and alarm indicator. Conventional detectors can be connected to input of the MCP. Without BUS communication, the detector operates as conventional MCP. Detector housing is included. Built in isolators maintaining loop integrity.

Technical Data

Operating voltage	8 ... 42 V DC
Quiescent current @ 19 V DC	approx. 45 µA
Alarm current w/o communication curtain	approx. 18 mA
No. of detector/zone	max. 127 detectors per loop (according to VdS)
Operation indicator	LED, green
Alarm display	red LED and yellow actuation indicator
Connection terminal	max. 2.5 mm ² (AWG 26-14)
Application temperature	-20 °C ... 70 °C
Storage temperature	-30 °C ... 75 °C
Air humidity	< 95 % (non-condensing)
Type of protection	IP43, IP55 with cover 704965
Housing	PC ASA plastic
Color	red, similar to RAL 3020
Weight	approx. 110 g
Detector specification	EN 54-11, type A
Dimensions	W: 88 mm H: 88 mm D: 21 mm W: 88 mm H: 88 mm D: 57 mm (with surface mount housing)
Declaration of Performance	DoP-20492130701



- 1 x Glass pane 704960
- 1 x Key 704966
- 1 x Multilingual paper labels with "Out of order" pictogram

Accessories

704980 Surface mount housing

804973

IQ8MCP compact, small, red, with resettable element



Approval: VdS

Same as 804971, but with plastic triggering element, which supports easy reset after an alarm has been triggered without having to replace the broken element (glass pane). Typically applied in nursery, clean rooms as for example in food processing industries.

Technical Data

Operating voltage	8 ... 42 V DC
Quiescent current @ 19 V DC	approx. 45 µA
Alarm current w/o communication curtain	approx. 18 mA
No. of detector/zone	max. 127 MCP per loop
Operation indicator	LED, green
Alarm display	red LED and yellow actuation indicator
Connection terminal	max. 2.5mm ² (AWG 26-14)
Application temperature	-20 °C ... 70 °C
Storage temperature	-30 °C ... 75 °C
Air humidity	< 95 % (non-condensing)
Type of protection	IP43 (in housing)
Housing	ASA plastic
Color	red, similar to RAL 3020
Weight	approx. 110 g
Detector specification	EN 54-11, type A
Dimensions	W: 88 mm H: 88 mm D: 21 mm W: 88 mm H: 88 mm D: 57 mm (with surface mount housing)



- 1x Plastic operating panel 704964
- 1x Key 704966
- 1x Multilingual paper insert with "Out of order" pictogram included

Accessories

704980 Surface mount housing

804961

IQ8MCP compact IP 66, small, red, with isolator glass pane



Features

- High IP protection class IP66
- Integrated loop isolator
- Triple key function (test, open, reset)
- Plug-in connection clamps
- Detectors that are not ready for operation can be marked with the "out of order" label by reversing the enclosed glass pane

Approval: G 205132

Suitable for esserbus and powered loop connection, with soft address coding, alarm latch and alarm indicator. Without BUS communication, the detector operates as conventional MCP. Detector housing, surface mount housing and transparent cover are included.

Due to the high IP protection IP66 suitable for use in humid areas. Surface mount housing is provided with knock-out cable entries for M20 cable glands (option) for simplified installation.

Technical Data

Operating voltage	8 ... 42 V DC
Quiescent current @ 19 V DC	approx. 45 µA
Alarm current @ 9 V DC	typ. 18 mA
No. of detector/zone	10 detectors / group; 127 detectors / ring (according to VdS)
Operation indicator	LED, green
Alarm display	LED, red and yellow flag
Connection terminal	max. 1,5 mm ² (AWG 30-14)
Application temperature	-20 °C ... 70 °C
Storage temperature	-30 °C ... 75 °C
Air humidity	< 95 % (non-condensing)
Type of protection	IP66
Housing	PC-ASA plastic
Color	red, similar to RAL 3020
Weight	approx. 250 g
Detector specification	EN 54-11, type A
Dimensions	W: 88 mm H: 88 mm D: 57 mm (with surface mount housing)

-  1 x Spare glass 704960
- 1 x Plastic spare key 704966
- 1 x transparent cover
- 1 x Surface mount housing



Example (optional fittings)

Plastic Housings



Housings for electronic modules Part No. 80495x.

Technical Data

Type of protection	IP 43, IP 55 with 704965
Housing	PC ASA plastic housing
Installation	surface mount
Weight	approx. 33 g
Dimensions	W: 88 mm H: 88 mm D: 21 mm

 1 x Key 704966

704950

Housing for small MCP, red, similar to RAL 3020

Pictogram according to EN54-11

Technical Data

Declaration of Performance	DoP-20492130701
----------------------------	-----------------

 The red manual call point housing is available only with the pictogram (as shown) according to EN 54-11.

Please note that according to EN54-11, the label for the MCP must include the symbol of the burning house.

704951

Housing for small MCP, blue, similar to RAL 5015

 Labeling foil set (white) for various international applications.

704952

Housing for small MCP, yellow, similar to RAL 1021

 Labeling foil set (black) for various international applications.

704953

Housing for small MCP, orange, similar to RAL 2011

 Labeling foil set (black) for various international applications.

704954

Housing for small MCP, green, similar to RAL 6002

 Labeling foil set (white) for various international applications.

Surface Mount Housings



The surface mount housing serves as cable entry for surface mount cabling. With integrated support for shielding.

Technical Data

Dimensions

W: 88 mm H: 88 mm D: 36 mm



Mounting material

704980

Surface mount housing for small MCP, red, similar to RAL 3020

Red, for manual call points Part No. 804970, 804971 and 804973, for small design electronic modules Part No. 804950/51, 804955/56 with housing Part No. 704950.

704981

Surface mount housing for small MCP, blue, similar to RAL 5015

Blue, for small design electronic modules Part No. 804950/51, 804955/56 with housing Part No. 704951.

704982

Surface mount housing for small MCP, yellow, similar to RAL 1021

Yellow, for small design electronic modules Part No. 804950/51, 804955/56 with housing Part No. 704952.

704983

Surface mount housing for small MCP, orange, similar to RAL 2011

Orange, for small design electronic modules Part No. 804950/51, 804955/56 with housing Part No. 704953.

704985

Surface mount housing for small MCP, gray, similar to RAL 7035

Gray, for small design electronic modules Part No. 804950/51, 804955/56 with housing Part No. 704953.

Electronic Modules - Conventional

804950

Conventional MCP electronic module

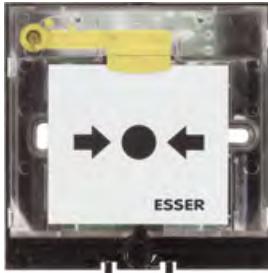

Approval: VdS

With alarm indicator, for the connection to a standard detector zone.

Technical Data

Operating voltage	8 ... 30 V DC
Quiescent current @ 9 V DC	approx. 0 μ A
Alarm current @ 9 V DC	typ. 9 mA
No. of detector/zone	max. 10 detectors per loop (as per VdS)
Alarm display	LED, red and yellow flag
Connection terminal	max. 2,5 mm ² (AWG 26-14)
Application temperature	-20 °C ... 70 °C
Storage temperature	-30 °C ... 75 °C
Air humidity	< 95 % (non-condensing)
Type of protection	IP 43 (in Housing), IP 55 with cover 704965
Weight	approx. 78 g
Detector specification	EN 54-11, type A
Dimensions	W: 88 mm H: 88 mm D: 21 mm W: 88 mm H: 88 mm D: 57 mm (with surface mount housing)
Declaration of Performance	DoP-20486130701



1 x Glass pane 704960

1 x Multilingual paper labels with "Out of order" pictogram

804951

Conventional MCP electronic module, with 2nd micro-switch

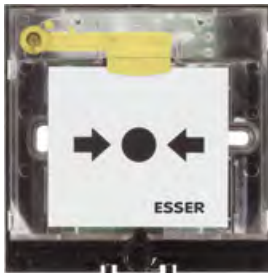

Approval: VdS

Same as 804950, but with second microswitch with dry contact NC/C (break) or NO/C (make) that is activated when the alarm is triggered.

Technical Data

Operating voltage	8 ... 30 V DC
Quiescent current @ 9 V DC	approx. 0 μ A
Alarm current @ 9 V DC	typ. 9 mA
Contact load	30 V DC/1 A
No. of detector/zone	max. 10 detectors per loop (as per VdS)
Alarm display	LED, red and yellow flag
Connection terminal	max. 2,5 mm ² (AWG 26-14)
Application temperature	-20 °C ... 70 °C
Storage temperature	-30 °C ... 75 °C
Air humidity	< 95 % (non-condensing)
Type of protection	IP 43 (in housing), IP 55 with cover 704965
Weight	approx. 78 g
Declaration of Performance	DoP-20485130701

Electronic Modules - Addressable

804955

IQ8MCP electronic module

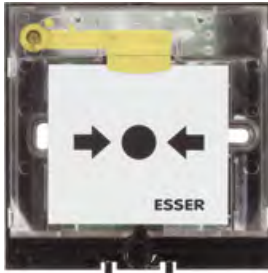

Approval: VdS

Same as 804971, but without housing.

Technical Data

Operating voltage	8 ... 42 V DC
Quiescent current @ 19 V DC	approx. 45 µA
Alarm current w/o communication curtain	approx. 18 mA
No. of detector/zone	max. 127 detectors per loop (as per VdS)
Operation indicator	LED, green
Alarm display	red LED and yellow actuation indicator
Connection terminal	max. 2.5 mm ² (AWG 26-14)
Application temperature	-20 °C ... 70 °C
Storage temperature	-30 °C ... 75 °C
Air humidity	< 95 % (non-condensing)
Type of protection	IP43 (in housing), IP 55 with cover 704965
Weight	approx. 78 g
Detector specification	EN 54-11, type A
Dimensions	W: 88 mm H: 88 mm D: 21 mm
Declaration of Performance	DoP-20492130701



1 x Glass pane 704960

1 x Multilingual paper labels with "Out of order" pictogram

804956

IQ8MCP electronic module w/o isolator, with relay

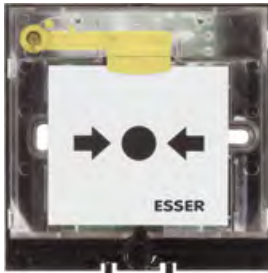

Approval: VdS

Same as 804955, but with relay and without loop isolator or connection possibility for standard manual call points. The relay output is activated by the triggering of this detector. The relay output can be programmed in the IQ8Control and System 8000 FACP customer data as a control group.

Technical Data

Operating voltage	8 ... 42 V DC
Quiescent current @ 19 V DC	approx. 45 µA
Alarm current w/o communication curtain	approx. 18 mA
Contact load	30 V DC / 1 A
No. of detector/zone	max. 127 detectors per loop (as per VdS)
Operation indicator	LED, green
Alarm display	LED, red and yellow flag
Connection terminal	max. 2.5 mm ² (AWG 26-14)
Application temperature	-20 °C ... 70 °C
Storage temperature	-30 °C ... 75 °C
Air humidity	< 95 % (non-condensing)
Type of protection	IP43 (in housing), IP 55 with cover 704965
Weight	approx. 78 g

704960

Spare glass pane for small MCP, EN54



Spare glass pane with white stick-on foil and printed pictogram in compliance with EN 54-11 (type A). Suitable for small MCPs.

Technical Data

Dimensions W: 56 mm H: 49.5 mm D: 1.85 mm

 To indicate that the detector is "Out-of-order" the operator has a corresponding pictogram on the reverse side.

 10 pcs

704975

Spare glass pane for small MCP, EN54, neutral

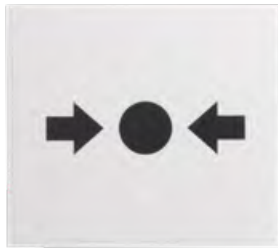

Spare glass pane with white stick-on foil and printed with pictogram according to EN 54-11 (type A), for small manual call points, without logo.

Technical Data

Dimensions W: 56 mm H: 49.5 mm D: 1.85 mm

 To indicate that the detector is "Out-of-order" the operator has a corresponding pictogram on the reverse side.

 10 pcs

704964

Resettable element for small MCP



Resettable, white plastic, for small manual call points. Typically applied, for instance, in food processing industries or in clean rooms.

Technical Data

Material ABS
 Dimensions W: 56 mm H: 49.5 mm D: 1.85 mm
 Declaration of Performance DoP-20492130701

 To indicate that the detector is "Out-of-order" the operator has the same pictogram as shown above on the reverse side.

 10 pcs



Application example

704965

Protective kit for MCP and TAL, transparent



Transparent, suitable for small MCPs. The cover serves as a protection to prevent inadvertent activation and to protect from high humidity.

Technical Data

Type of protection	IP55
Material	plastic cover, transparent

Cover and two neoprene seals

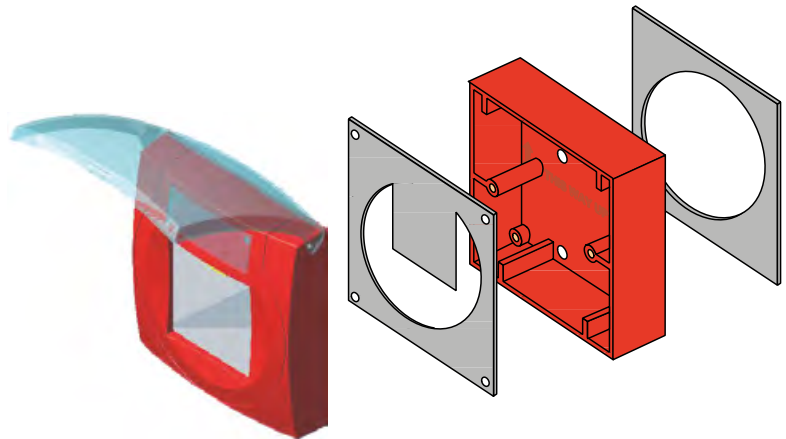

Application example: Manual call point with mounted cover

704966

Plastic spare key for small MCP



Plastic key, red, suitable for small manual alarm units.

10 pcs

704967

Mounting frame for small MCP, red and white



The mounting frame is useful for mounting MCPs on different international flush mount boxes.

Technical Data

Color	red, similar to RAL 3020 white, similar to RAL 9010
Dimensions	W: 132 mm H: 132 mm D: 8 mm

2 x Fastening screws are included (red and white)

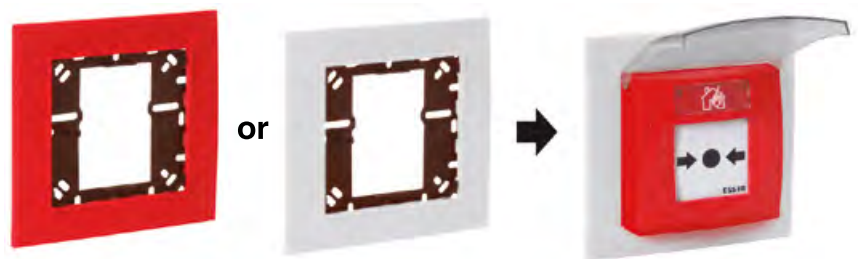

Application example: Mounting frame with small MCP

761694

Addressable MCP, IP66

Approval: G 209190

Addressable manual call point in conformity with EN 54-11 type B with loop isolator for manually triggering fire alarms or hazard alarms. For outdoor application or application in damp environments.

Technical Data

Operating voltage	8 ... 42 V DC
Quiescent current @ 19 V DC	approx. 45 µA
No. of detector/zone	max. 10 (according to VdS), 127 / loop
Alarm display	LED, red
Connection terminal	max. 1.5 mm ²
Application temperature	-20 °C ... 70 °C
Storage temperature	-25 °C ... 75 °C
Air humidity	< 95 % (non-condensing)
Type of protection	IP66
Housing	PC-plastic
Color	red, similar to RAL 3000
Weight	approx. 475 g
Dimensions	W: 135 mm H: 135 mm D: 61 mm
Declaration of Performance	DoP-20882130701

 Please take note, our Part No. 769910 and 769911 can be used as spare keys.

To indicate that the detector is "Out-of-order" the operator has to insert the paper inlay, which has a corresponding pictogram and wording.

 1 x Glass 704910
1 x Key and "Out of order" sign or "Außer Betrieb"

Accessories

704910 Spare glass for MCP
769910 Plastic key for large MCP
769911 Metal key for large MCP

W1A-R1K0SG-U007-01

Conventional MCP, IP67, small housing, red**Features**

- Sealed to IP 67
- Unique 'plug and play' installation concept
- Anti-tamper facility
- Enhanced aesthetics and compact design
- Approved to EN 54-11

The outdoor MCP is an IP 67 sealed product. The enhanced environmental protection allows the unit to be installed in many external environments where water and dirt are likely to be present, making it a true waterproof and outdoor product.

The manual call point has a unique 'plug and play' concept designed specifically to reduce installation time. The product utilizes a special terminal block, where all initial installation cabling is terminated. This terminal block is then simply connected to the back of the MCP. The housing is supplied with three standard 20mm knock outs for cable entries, accommodating all types of surface wiring installations.

The MCP also helps to preserve the integrity of the overall system as illegal removal of the product lid will result in the call point operating and the system triggering an alarm.

Technical Data

Application temperature	-30 °C ... 70 °C
Storage temperature	-30 °C ... 70 °C
Air humidity	< 95 % non condensing
Type of protection	IP 67
Material	PC/ABS
Weight	approx. 240 g
Detector specification	EN 54-11
Dimensions	W: 97.5 mm H: 93 mm D: 71 mm

 1 x Cable gland included

Accessories

MUS155 Spare glass pane (5 pcs)
SC070 Spare key
PS200 Plastic cover

Manual Call Points Intrinsically Safe

W1A-R1K0SG-E019-81

Conventional Ex MCP, IP67, small housing, red



Features

- Sealed to IP67
- Unique 'plug and play' installation concept
- Anti-tamper facility
- Enhanced aesthetics and compact design
- Approved to EN 54-11

Approval: LPCB, ATEX

The Ex MCP is built especially for installation in hazardous areas. It is intended for outdoor use within intrinsically safe systems using suitable barriers.

The outdoor MCP is an IP 67 sealed product. The enhanced environmental protection allows the unit to be installed in many external environments where water and dirt are likely to be present, making it a true waterproof and outdoor product.

The manual call point has a unique 'plug and play' concept designed specifically to reduce installation time. The product utilizes a special terminal block, where all initial installation cabling is terminated. This terminal block is then simply connected to the back of the MCP. The housing is supplied with three standard 20mm knock outs for cable entries, accommodating all types of surface wiring installations.

The MCP also helps to preserve the integrity of the overall system as illegal removal of the product lid will result in the call point operating and the system triggering an alarm.

Technical Data

Application temperature	-25 °C ... 70 °C
Storage temperature	-25 °C ... 70 °C
Air humidity	< 93 % ±3% non condensing
Type of protection	IP67
Material	PC/ABS
Weight	approx. 350 g
Detector specification	EN 54-11
ATEX certificate	Sira 06ATEX2131X
Ex-category	II 1GD EEXialICT
Dimensions	W: 97.5 mm H: 93 mm D: 71 mm



! Attention – cable glands not included in delivery.

Accessories

MUS155 Spare glass pane (5 pcs)
 SC070 Spare key
 PS200 Plastic cover

804960.EX

Small Conventional MCP Ex (i) IP 66/67, red with glass pane



Features

- High IP protection class IP66 & IP67
- Triple key function (test, open, reset)
- Plug-in terminals
- "Out of Order" indication of an inoperative alarm by flipping over the glass pane

Approval: G 214115

The small compact version has detector housing, surface mount housing, transparent cover, and alarm indicator. For connection to a conventional zone for use in ex-areas. Suitable for use in damp rooms thanks to the high IP 66/67 IP protection. Surface mounting housing is provided with break-out cable entries for M20 cable glands (optional) for easy installation.

Technical Data

Data according to ATEX:

Max. Input Voltage (Ui)	21 V DC
Max. Input current (Ii)	252 mA
Ambient temperature (Ta)	-20 °C ... 70 °C
EC-type examination certificate	TÜV 14 ATEX 150860
Ex-category	II 2G (with Ex barrier Part-No. 764744 / 804744)
Explosion protection Specification	Ex ib IIC T4 Gb EN 60079-0:2012 + A11:2013 / -11:2012

Common technical data:

Operating voltage	8 ... 30 V DC
Alarm current @ 9 V DC	typ. 9 mA
Alarm display	red LED and yellow actuation indicator
Connection terminal	max. 1,5 mm ² (AWG 30-14)
Application temperature	-20 °C ... 70 °C
Storage temperature	-20 °C ... 70 °C
Air humidity	< 95 % (non condensing)
Type of protection	IP66, IP67
Material	PC ASA plastic
Weight	approx. 255 g
Color	red, similar to RAL 3020
Detector specification	EN 54-11 : 2001 + A1:2005, Typ A
Dimensions	W: 88 mm H: 88 mm D: 63 mm (w. surface mount h.)
Declaration of Performance	DoP-21415141219



Use M20 cable glands with 15 mm connecting thread length and sealing ring, e.g. blueglobe by Pflitsch (cable gland Part No.: bg 820PA/sealing ring Part No.: DRF 220).
For detailed information on installation and operation, see documentation Part No. 798920.
For operation with standard groups ex-barrier Part No. 764744 must be used in zone 1 and zone 2!



1 x glass pane 704960
1 x key 704966
1 x surface mounting housing
1 x transparent cover

804961.EX

Small IQ8MCP Ex (i) IP 66/67, red with glass pane



Features

- High IP protection class IP66 & IP67
- Triple key function (test, open, reset)
- Plug-in terminals
- "Out of Order" indication of an inoperative alarm by flipping over the glass pane

Approval: G 214116

The small compact fully addressable (esserbus) intrinsically safe MCP version has detector housing, surface mount housing, transparent cover, and alarm indicator. For use in the esserbus and powered loop with soft address coding, alarm latch and alarm indicators. The detector operates like a conventional MCP without the bus connection. IQ8MCP without loop isolator, especially for use in ex-areas. Suitable for use in damp rooms thanks to the high IP 66/67 IP protection. Surface mounting housing is provided with break-out cable entries for M20 cable glands (optional) for easy installation.

Technical Data

Data according to ATEX:

Max. Input Voltage (Ui)	21 V DC
Max. Input current (Ii)	252 mA
Ambient temperature (Ta)	-20 °C ... 70 °C
EC-type examination certificate	TÜV 14 ATEX 150789
Ex-category	II 2G (with Ex barrier Part-No. 764744 / 804744)
Explosion protection Specification	Ex ib IIC T4 Gb EN 60079-0:2012 + A11:2013/-11:2012/-25:2010

Common technical data:

Operating voltage	8 ... 342 V DC
Alarm current @ 19 V DC	typ. 45 mA
Alarm display	red LED and yellow actuation indicator
Connection terminal	max. 1,5 mm ² (AWG 30-14)
Application temperature	-20 °C ... 70 °C
Storage temperature	-20 °C ... 70 °C
Air humidity	< 95 % (non condensing)
Type of protection	IP66, IP67
Material	PC ASA plastic
Weight	approx. 255 g
Color	red, similar to RAL 3020
Detector specification	EN 54-11 : 2001 + A1:2005, Typ A
Dimensions	W: 88 mm H: 88 mm D: 63 mm (w. surface mount h.)
Declaration of Performance	DoP-21415141219



Use M20 cable glands with 15 mm connecting thread length and sealing ring, e.g. blueglobe by Pflitsch (cable gland Part No.: bg 820PA/sealing ring Part No.: DRF 220).

For detailed information on installation and operation, see documentation Part No. 798920.

For operation with standard groups ex-barrier Part No. 764744 must be used in zone 1 and zone 2!



- 1 x glass pane 704960
- 1 x key 704966
- 1 x surface mounting housing
- 1 x transparent cover

804920.EX

Large Conventional MCP Ex (i) IP 66/67, red with glass pane



Features

- High IP protection up to IP55
- Plug-in terminals
- Standard keys with double function: Open, reset
- Service key with triple function: Test, open, reset
- "Out of Order" marking an inoperative detector by turning the enclosed operating front foil

Approval: G 214113

Standard large intrinsically safe MCP, consisting of electronic module and detector housing, for connection to a conventional zone, especially for use in hazardous areas. Suitable due to the high IP protection up to IP 55 for use in damp rooms.

Technical Data

Data according to ATEX:

Max. Input Voltage (U _i)	21 V DC
Max. Input current (I _i)	252 mA
Ambient temperature (T _a)	-20 °C ... 70 °C
EC-type examination certificate	TÜV 14 ATEX 150860
Ex-category	II 2G (with Ex barrier Part-No. 764744 / 804744)
Explosion protection Specification	Ex ib IIC T4 Gb EN 60079-0:2012 + A11:2013 / -11:2012

Common technical data:

Operating voltage	8 ... 30 V DC
Alarm current @ 9 V DC	typ. 9 mA
Alarm display	LED, red
Connection terminal	max. 1,5 mm ² (AWG 30-14)
Application temperature	-20 °C ... 70 °C
Storage temperature	-30 °C ... 75 °C
Air humidity	< 95 % (non condensing)
Type of protection	IP44, IP55 with shrink sleeve
Material	PC ASA plastic
Weight	approx. 236 g (in housing)
Color	red, similar to RAL 3020
Detector specification	EN 54-11: 2001 + A1:2005, Typ A
Dimensions	W: 133 mm H: 133 mm D: 36 mm
Declaration of Performance	DoP-21415141219



For detailed information on installation and operation, see documentation part no. 798920. For operation with standard groups ex-barrier item no. 764744 must be used in zone 1 and zone 2!



- 1 x glass pane 704960
- 1 x key 769910
- 1 x Manual call point housing, red
- 1 x IP 55 shrink sleeve

804924.EX



Features

- High IP protection up to IP55
- Plug-in terminals
- Standard keys with double function: Open, reset
- Service key with triple function: Test, open, reset
- "Out of Order" marking an inoperative detector by turning the enclosed operating front foil

Large IQ8MCP Ex (i), red with glass pane

Approval: G 214114

Fully addressable large intrinsically safe IQ8MCP, consisting of electronic module and detector housing, for use in the esserbus and powered loop with soft address coding, alarm latch, and alarm indicator. The detector operates like a conventional MCP without the bus connection. IQ8MCP without loop isolator, especially for use in ex-areas. Operation with individual addressing at ex-barrier 804744. Suitable due to the high IP protection up to IP 55 for use in damp rooms.

Technical Data

Data according to ATEX:

Max. Input Voltage (Ui)	21 V DC
Max. Input current (Ii)	252 mA
Ambient temperature (Ta)	-20 °C ... 70 °C
EC-type examination certificate	TÜV 14 ATEX 150789
Ex-category	II 2G (with Ex barrier Part-No. 764744 / 804744)
Explosion protection Specification	Ex ib IIC T4 Gb EN 60079-0:2012 + A11:2013/-11:2012/-25:2010

Common technical data:

Operating voltage	8 ... 42 V DC
Alarm current @ 19 V DC	typ. 45 mA
Alarm display	LED, red
Connection terminal	max. 1,5 mm ² (AWG 30-14)
Application temperature	-20 °C ... 70 °C
Storage temperature	-30 °C ... 75 °C
Air humidity	< 95 % (non condensing)
Type of protection	IP44, IP55 with shrink sleeve
Material	PC ASA plastic
Weight	approx. 236 g (in housing)
Color	red, similar to RAL 3020
Detector specification	EN 54-11: 2001 + A1:2005, Typ B
Dimensions	W: 133 mm H: 133 mm D: 36 mm
Declaration of Performance	DoP-21415141219



For detailed information on installation and operation, see documentation part no. 798920. For operation with standard groups ex-barrier item no. 764744 must be used in zone 1 and zone 2!



- 1 x glass pane 704960
- 1 x key 769910
- 1 x Manual call point housing, red
- 1 x IP 55 shrink sleeve

PS200



Transparent cover for MCP W1A

Spare transparent cover for conventional manual points.

SC070



Spare keys pack for MCP W1A

10 spare keys for conventional MCP. The MCP key is used to open, reset and test the MCPs.



10 pieces

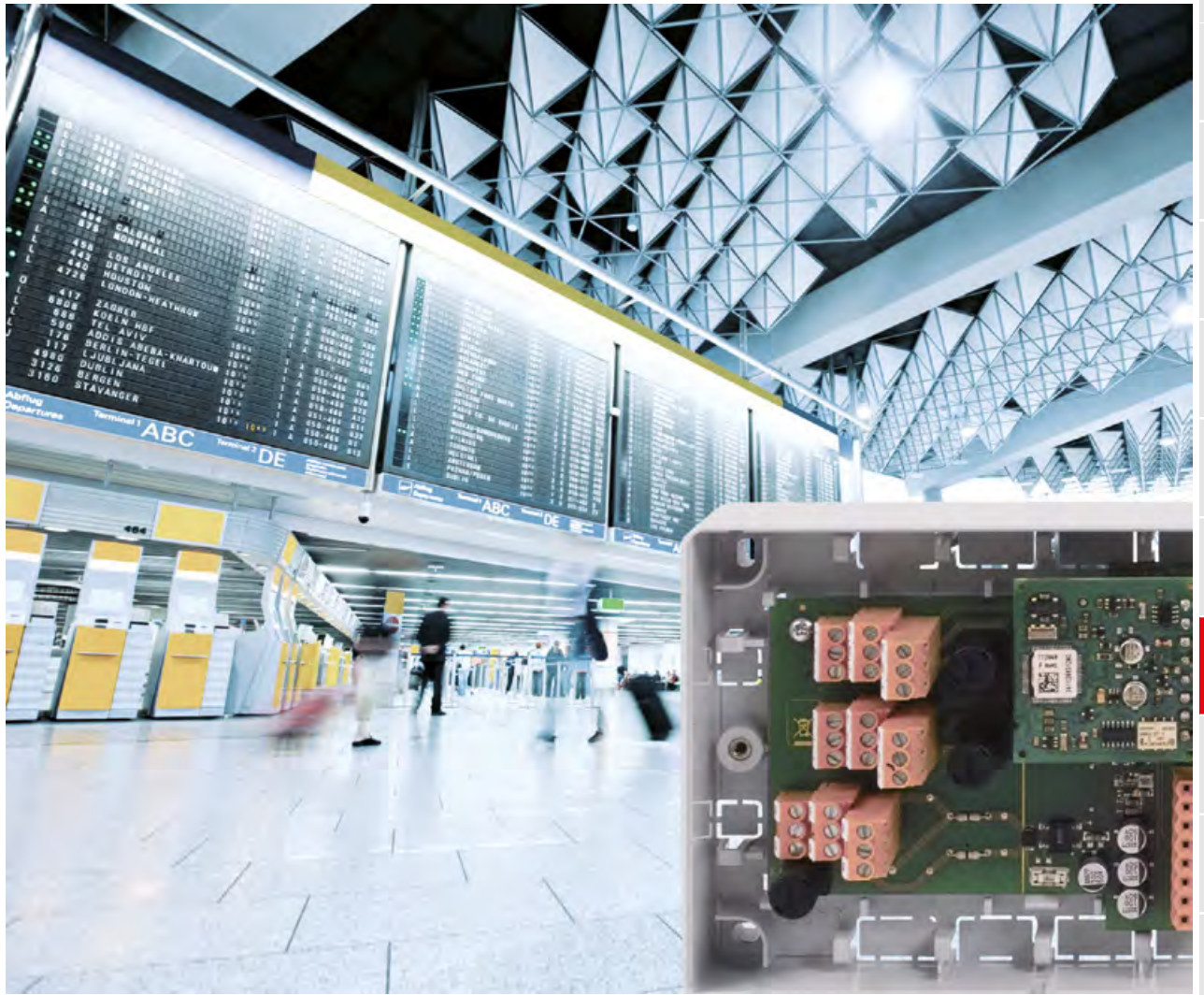

Transponders / Input & Output Modules

esserbus

120-132

Professional fire detection systems are expected to provide more than reliable fire detection and signaling alarms to the fire brigade. Over time, the continuous progress in technical units has led to many improvements in monitoring and control systems. At the same time the specifications of the European standards are becoming more and more demanding. These complex requirements towards control and monitoring of individual parts of a unit was reason enough to redesign our assortment of esserbus transponders.

Essentially the new assortment consists of the so-called "alarm transponder" which is used for both the connection of non-addressable detectors (point-type detectors, manual detectors and special detectors) as well as for the operation of conventional alarm signaling devices (signaling devices, signal flasher and combination alarm signaling devices). Monitoring of the lines in accordance with the latest standards is ensured via "EOL modules" (end-of-line modules).

The second part is formed by the "FCT" (fire control transponder) and the IQ8TAL being loop-powered input and output transponders with a contact input and a floating relay output for monitoring of contacts and transmission of technical alarms for equipment monitoring.

These modules with low power consumption are for interfacing to other disciplines which are not a part of the fire detection system itself. Thanks to their intelligent concept they significantly expand the range of monitoring and control functions as part of the building management.

Take note, esserbus transponders need ONLY ONE loop address per device, anyway how much inputs or outputs are switched - i.e. in case that more than one input/output per device is needed, this feature reduces the quantity of transponders needed!

808623

esserbus alarm transponder, 4 IN/2 OUT with isolator



Features

- Only one loop address is needed per transponder
- Digital inputs
- Integrated loop isolator
- Conventional connection of standard fire detectors and signaling devices
- Loop monitoring in compliance with EN 54-13
- Integrated loop isolator
- Programmable relay outputs
- Programmable relay reset function
- Max. 100 transponders per FACP
- Max. 31 transponders per loop
- Max. 127 detector zones per loop
- Detector numbers per zone input of the transponder:
 - Max. 30 conventional detectors (without SOC)
 - Max. 10 conventional detectors (with SOC)
 - Max. 10 Manual call points (MCP)
 - Max. 10 Technical Alarm Modules (TAM)
- Max. 5 audible alarm devices per each output (observe calculation table in tools 8000)

Approval: VdS

The esserbus transponder functions as a device on the multi-functional primary line. The connection of four zones with automatic standard detectors, manual call points (non-addressable) as well as special detectors is possible. In addition, two programmable relay outputs are also available. Both relay outputs of the transponder may be used to reset a connected third-party detector. The reset function relates to the corresponding special detector, e.g. by switching the appropriate input to GND or by a short interruption of the detectors supply voltage. Therefore the control mode >Reset-Relay< as well as the desired relay operation mode (normally closed or open) must be configured with the programming software tools 8000 from V1.15 and above. The relay output will be activated for the selected reset time (1 to 14 seconds) if the assigned input (G1 for relay 1/G2 for relay 2) of the transponder is reset. Refer to the detectors manual for the required reset time.

Monitoring via the EOL terminating devices (Part No. 808624/808626) is required for the connection of fire detectors and for the controlling of alarm signaling devices. The enclosed resistors can be used to connect the floating contacts.

The esserbus alarm transponder requires an external voltage supply. An optional Voltage Converter (Part No. 781336) is also required for 12V DC operation. The esserbus alarm transponder external voltage supply can be monitored during operation.

The EOL-I terminating device (Part No. 808626) must be used for standard-compliant monitoring of detector zone inputs. The EOL-O (Part No. 808624) must be used for standard-compliant monitoring of connected alarm signaling devices.

Technical Data

Operating voltage	10 ... 28 V DC
Quiescent current @ 12 V DC	approx. 12 mA
Current consumption	max. 120 mA @ 12 V DC
Contact load relay	30 V DC / 1 A
Ambient temperature	-10 °C ... 50 °C
Storage temperature	-25 °C ... 75 °C
Air humidity	< 95 % (non-condensing)
Type of protection	IP 40 (in housing)
Weight	approx. 28 g
Dimensions	W: 82 mm H: 72 mm D: 20 mm
Declaration of Performance	DoP-21057130701



Installation accessory pack

Accessories

- 788603.10 Module housing for snap-on mounting rail
- 788600 Housing surface mount, gray
- 788650.10 Housing surface mount, white
- 788601 Housing flush mount, gray
- 788651.10 Housing flush mount, white
- 788612 Loop isolator for transponder
- 781336 DC/DC converter output voltage
- 808624 EOL-O Terminating device
- 808626 EOL-I Terminating device

808623.10

esserbus transponder for UniVario with isolator



Features

- Only one loop address is needed per transponder
- Digital input
- Loop monitoring in compliance with EN 54-13
- Integrated loop isolator
- Programmable relay outputs
- Programmable relay reset function
- Max. 100 transponders per fire alarm control panel
- Max. 31 transponders per loop
- Max. 127 detector zones per loop
- Detector numbers per zone input of the transponder:
- Max. 30 conventional detectors (without SOC)
- Max. 10 conventional detectors (with SOC)
- Max. 10 Manual call points
- Max. 10 Technical Alarm Modules (TAM)
- Max. 5 audible alarm device (observe calculation table in tools 8000)

Approval: VdS

The interface connects max. 2 industrial sensors from the UniVario product range. These sensors are supplied with energy via the 9 V DC group voltage input. For meeting the standard requirements of monitoring, an EOL-UV terminal element is connected to the sensor base of the UniVario sensor. The interface requires external voltage supply. Additionally, two optionally monitored relay outputs are available.

Technical Data

Operating voltage	10 ... 28 V DC
Quiescent current @ 12 V DC	approx. 12 mA
Current consumption	max. 120 mA @ 12 V DC
Contact load relay	30 V DC / 1 A
Ambient temperature	-10 °C ... 50 °C
Storage temperature	-25 °C ... 75 °C
Air humidity	< 95 % (non-condensing)
Type of protection	IP 40 (in housing)
Weight	approx. 28 g
Dimensions	W: 82 mm H: 72 mm D: 20 mm
Declaration of Performance	DoP-21057130701



Installation Accessory Pack

Accessories

788603.10	Module housing for snap-on mounting rail
788600	Housing surface mount, gray
788650.10	Housing surface mount, white
788601	Housing flush mount, gray
788651.10	Housing flush mount, white
788612	Loop isolator for transponder
781336	DC/DC converter output voltage
808626	EOL-I Terminating Device

808623.40

NEW



Features

- 4 detector group inputs for conventional connection of special fire detectors
- Line monitoring acc. to EN 54-13 possible
- Integrated loop isolator
- 2 programmable relay outputs for reset of the special detector with flexible reset times

esserbus transponder for special detectors

For connection of special detectors and associated reset functions with evaluation of pre-alarm, fault and alarm. The transponder module can be adapted to the different reset behaviour of the connected special detectors. The inputs and outputs of the transponder can be linked together in such a way that switching on or resetting a signal input leads to short-term activation of the reset input of the special detector. In order, to support various special detectors, the inputs of the transponder can be programmed with a suppression time of up to 255 seconds at reset.

Technical Data

Operating voltage	10 ... 30 V DC
Quiescent current @ 12 V DC	approx. 12 mA
Current consumption	max. 120 mA @ 12 V DC
Contact load relay	30 V DC / 1 A
Ambient temperature	-10 °C ... 50 °C
Air humidity	< 95 % (non-condensing)
Type of protection	IP 40 (in housing)
Weight	approx. 28 g
Dimensions	W: 82 mm H: 72 mm D: 20 mm
Declaration of Performance	DoP-21057130701



The transponder can only be operated at a FlexES Control with the above mentioned features. At IQ8Control and Compact series control panels, the loop devices behaves like an Alarm transponder. Minimum requirements: Tools 8000 ≥ V1.25R000 FlexES Control ≥ V4.07R000 (Container V1.06)

Accessories

781137	DC/DC converter output voltage 24 V DC for the standard-compliant monitoring of the power supply
808624	EOL-O terminating device for the standard-compliant monitoring of the power supply

808621

esserbus transponder IQ8FCT LP



Features

- Module for controlling and monitoring fire protection devices
- Power supply via the field bus esserbus
- Output switching load up to 230 V AC / 16 A
- Programmable run-time monitoring
- Configurable fail safe functionality
- Manual output activation at transponder
- Robust IP 65 protected surface mount housing
- Silicone cable entries for fast installation

Approval: VdS G 209138

The IQ8FCT LP is used to control and monitor external fire control devices like fire dampers or as a technical alarm component (TAL) to monitor an external contact and control external load. The transponder is connected on the esserbus/esserbus-Plus loop of fire control system FlexES Control and IQ8Control.

FCT functionality

In this function a fire control device e.g. fire damper is connected to the relay output of the IQ8FCT LP and controlled according to the programming with configured runtime. Via the input the end positions of this external device are monitored. If the external device is leaving the set position e.g. at a power loss or is stuck a failure is recognized and indicated at the IQ8FCT LP and the fire control panel. The IQ8FCT LP is also equipped with configurable fail save functionality. If enabled, a communication loss with control panel results in automatic selfactivation of relay output.

TAL functionality

Here an external contact can be connected and monitored via the input of the IQ8FCT LP. In case of an activation of this contact, the address and programmed additional text of the corresponding technical alarm module IQ8FCT LP will be displayed.

Technical Data

Operating voltage	14 ... 42 V DC
Quiescent current @ 19 V DC	approx. 45 mA
Relay contact	max. 16 A resistive or 8 A inductive load of 230 V AC or 30 V DC surge resistance 250 A @ 10 ms potential-free or voltage switching / COM/NO/NC
Input monitoring (at use of external resistors)	FCT mode: 1 k / 6 k8 / 10 k TAL mode: 1 k / 10 k (NO) or 6 k8 / 10 k (NC)
Input line length	500 m
System limitations	max. 127 pieces per loop
Input / loop terminals	max. 2,5 mm ² (AWG 26-14)
Relay contact / power supply terminals	max. 6 mm ² (AWG 30-10)
Ambient temperature	-20 °C ... 70 °C
Storage temperature	-30 °C ... 75 °C
Air humidity	< 95 % (non-condensing)
Type of protection	IP65
Color	gray, similar to RAL 7035
Weight	approx. 250 g
Dimensions	W: 150 mm H: 116 mm D: 67 mm
Declaration of Performance	DoP-20792130701

Accessories

804870 Alarm and monitoring module for IQ8TAM

808606

esserbus transponder IQ8FCT XS



Features

- Module for controlling and monitoring fire protection devices
- Compatible with FlexES Control and IQ8Control
- Power supply via the field bus esserbus
- Integrated loop isolator
- Programmable run-time monitoring (fire dampers)
- Space-saving installation due to compact design
- Installation on hat rail 35 mm
- Optional housing for surface mounting

Approval: VdS G 209138

The IQ8FCT XS can be used to control and monitor external fire protection devices like fire dampers or as a technical alarm module (TAL) to monitor an external contact and control external load.

The transponder is connected on the esserbus® /esserbus®-PLus loop of fire control system FlexES Control and IQ8Control.

FCT functionality

In this function a fire control device e.g. fire damper will be connected to the relay output of the IQ8FCT XS and controlled according to the programming with configured runtime. Via the input the end positions of this external device are monitored. If the external device is leaving the set position e.g. at a power loss or is stuck a failure is recognized and indicated at the IQ8FCT XS and the fire control panel.

TAL functionality

Here an external contact can be connected and monitored via the input of the IQ8FCT XS. In case of an activation of this contact, the address and programmed additional text of the corresponding technical alarm module IQ8FCT XS will be displayed.

Technical Data

Operating voltage	14 ... 42 V DC
Quiescent current @ 19 V DC	approx. 45 mA
Relay contact	max. 1 A / 30 V DC at AC potential-free / COM / NO / NC
Input monitoring	FCT mode: 1 k / 6 k8 / 10 k TAL mode: 1 k / 10 k (NO)
Input line length	500 m
System limitations	max. 127 pieces per loop
Input / loop terminals	max. 2,5 mm ² (AWG 26-14)
Ambient temperature	-20 °C ... 70 °C
Storage temperature	-30 °C ... 75 °C
Air humidity	< 95 % (non-condensing)
Type of protection	IP30 IP50 (w. housing M200SMB/SMB6-V0)
Color	gray, similar to RAL 7035
Weight	approx. 90 g approx. 250 g (w. housing M200SMB) approx. 790 g (w. housing SMB6-V0)
Dimensions	W: 90 mm H: 93 mm D: 93 mm W: 130 mm H: 143 mm D: 49 mm (w. h. M200SMB) W: 245 mm H: 180 mm D: 100 mm (w. h. SMB6-V0)
Declaration of Performance	DoP-20792130701

Accessories

804870 Alarm and monitoring module for IQ8TAM

M200SMB Surface mounting housing for one module

SMB6-V0 Surface mounting housing for 6 modules

808610.10

esserbus transponder 12 relays (8 bit)



Features

- Only one loop address is needed per transponder
- Max. 100 transponders per FACP
- Max. 32 transponders per loop
- Max. 32 transponders per detector zone

Approval: VdS, CNBOP, BOSEC

The esserbus transponder works as a loop device on the multi-functional primary line. With the 12 relays module, it is possible to expand the number of exits per control unit. Depending on the control unit, it can be integrated or used with fire detectors in mixed operation. The esserbus transponder can be optionally extended by adding the additional isolator board Part No. 788612. esserbus transponder voltage supply: via the multi-functional primary line. The esserbus transponder can be wired with an external switching voltage of 12V DC or 24V DC for the K1 to K12 relays. The external voltage supply of the transponder can be programmed to be monitored in the customer data in the operating mode. In the "floating" operating mode, no external switching voltage of the relays is necessary. 11 relays are freely programmable. The maximum line length from the transponder to the external device is up to 1000 m.

Technical Data

Operating voltage	10 ... 28 V DC
Quiescent current @ 19 V DC	approx. 250 µA
Current consumption @ 12 V DC	approx. 3 mA
Contact load relay	30 V DC / 1 A (max. 3 A each transponder)
Ambient temperature	-10 °C ... 50 °C
Storage temperature	-25 °C ... 75 °C
Air humidity	< 95 % (non-condensing)
Type of protection	IP 40 (with housing)
Weight	approx. 110 g
Dimensions	W: 150 mm H: 82 mm D: 20 mm
Declaration of Performance	DoP-20611130701



External power supply is only optional – the transponder is fully operational with loop powering only.

Accessories

788612	Loop isolator PCB
788600	Surface mounting housing gray, similar to RAL 7035
788650.10	Surface mounting housing white, similar to RAL 9003
788601	Flush mounting housing gray, similar to RAL 7035
788651.10	Flush mounting housing white, similar to RAL 9003

808611.10

esserbus transponder 32 LED



Features

- Only one loop address is needed per transponder
- Max. 100 transponders per FACP
- Max. 32 transponders per loop
- Max. 32 transponders per detector zone

Approval: VdS, CNBOP, BOSEC

The esserbus transponder works as a loop device on the multi-functional primary line. 32 optocoupler outputs for direct LED control (e.g. indicator) are found on this esserbus transponder module. There is one terminal screw per output on the switching mechanism. The module can be extended by adding the additional isolator board Part No. 788612. esserbus transponder voltage supply: via the multi-functional primary line. The esserbus transponder requires an external power supply.

The external voltage supply of the transponder can be programmed to be monitored in operating mode. The maximum line length from the transponder to the external device is up to 100 m.

Technical Data

Operating voltage	10 ... 15 V DC
Quiescent current @ 12 V DC	approx. 3 mA
Ambient temperature	-10 °C ... 50 °C
Storage temperature	-25 °C ... 75 °C
Air humidity	< 95 % (non-condensing)
Type of protection	IP 40 (with housing)
Weight	approx. 95 g
Dimensions	W: 150 mm H: 82 mm D: 20 mm
Declaration of Performance	DoP-20611130701

Accessories

788612	Loop isolator PCB
788600	Surface mounting housing gray, similar to RAL 7035
788650.10	Surface mounting housing white, similar to RAL 9003
788601	Flush mounting housing gray, similar to RAL 7035
788651.10	Flush mounting housing white, similar to RAL 9003

808615

esserbus communication transponder for ECP 8010



With this esserbus transponder the extinguishing relay output 8010 can be integrated on the bus of panel 8000, IQ8Control and FlexES, thus enabling several extinguishing zones to be networked with each other. On each bus, a maximum of eight 8010 extinguishing relay outputs can be operated and a maximum of 16 communication transponders for each FACP8000 C/M, IQ8Control and FlexES. All indicators and controls can be activated from the fire alarm panel. The communication transponder occupies one address on the esserbus. With integrated loop isolator on board. Maximum 8 transponders per loop and max. 16 transponders per FACP.

Technical Data

Current consumption	max. 28 mA
Ambient temperature	-10 °C ... 50 °C
Storage temperature	-25 °C ... 75 °C
Air humidity	< 95 % (non-condensing)
Type of protection	IP 40 (with housing)
Weight	approx. 28 g
Dimensions	W: 72 mm H: 65 mm D: 20 mm



Mounting: in the housing of the 8010 extinguishing relay output



Including loop isolator PCB (Part No. 788612)

808619.10

esserbus FSA transponder for fire doors



Features

- Only one loop address is needed per transponder
- Usage of series 9200 intelligent detectors (such as OT, OTI, O²T detectors) as FSA detectors is possible
- Connection of IQ8Quad O detectors (Part No. 802371), TD Detectors (Part No. 802271), OT detectors (Part No. 802373) and O²T detectors (Part No. 802374) (DIBt-approved) as FSA detectors is possible
- FSA detectors programmable as devices in the loop
- Status indicator of door arrester system to the FACP
- Actuation of the locking device also via the automatic fire detectors in non-FSA operation
- Stand-alone operation of the FSA transponders is possible
- Usage of IQ8Quad O detectors (Part No. 803371), TD detectors (Part No. 803271) and O²T detectors (Part No. 803374) in stand-alone operation of the FSA transponders to the standard detector group is possible
- Max. 100 transponders per FACP
- Max. 32 transponders per analog loop
- Max. 127 detector zones per analog loop
- Detector numbers per zone input of the transponder:
 - Max. 30 conventional detectors (without SOC)
 - Max. 10 conventional detectors (with SOC)
 - Max. 10 Manual call points
 - Max. 10 Technical Alarm Modules (TAM/TAL)

Approval: VdS

The transponder is suitable for usage for various applications: in stand-alone operation or on the esserbus. In esserbus operation, the Series 9200 automatic fire detectors and those of the IQ8Quad family (see features for types) can be used as detectors in door arrester systems (FSA - Fire, Failure and Shut-Off). In FSA transponder loop operation, the door arrester system status is indicated on the fire alarm control panel.

For stand-alone operation, detectors of the IQ8Quad family are supported without loop isolator (see features for types).

For operation, the transponder requires an external supply voltage. It is possible to monitor this voltage.

Technical Data

Operating voltage	10 ... 28 V DC
Quiescent current @ 12 V DC	approx. 6 mA (from UB ext)
Current consumption	max. 28 mA (from UB ext)
Contact load relay	max. 30 V DC/1 A or 48 V DC/0,5 A
Ambient temperature	-5 °C ... 50 °C
Storage temperature	-25 °C ... 75 °C
Air humidity	< 95 % (non-condensing)
Type of protection	IP 40 (with housing)
Weight	approx. 70 g
Dimensions	W: 72 mm H: 65 mm D: 20 mm (PC Board)
Declaration of Performance	DoP-20614130701

 Corresponding connection examples for FSA transponder operation in stand-alone operation or as a device in the fire detection System 8000 can be found in the chapter containing automatic door release systems.

Accessories

788612	Loop isolator PCB
788603.10	Module housing for C-mounting bar or top hat rail mounting
788600	Housing surface mount, gray
788650.10	Housing surface mount, white
788601	Housing flush mount, gray
788651.10	Housing flush mount, white
808625	EOL-Z

808630.10

esserbus transponder RZT, 24 V



Features

- For connection of 3rd party detectors
- Only one loop address is needed per transponder
- Max. 100 transponders per FACP
- Max. 31 transponders per loop
- Max. 32 transponders per detector zone

Approval: VdS

The refurbishment zone transponder is a stand-alone participant on the esserbus for the fire alarm system 8000 and IQ8Control FACP. Individual automatic fire detectors and manual call points (conventional technology) from other manufacturers can be connected to the 4 zone inputs. The voltage of all 4 zones can be configured to 24 V via the internal DC/DC module. An additional reset module is not required to operate third-party detectors. The two relay outputs are available for general control purposes.

Programmable with the programming software tools 8000 Version V2.40 or higher.

Technical Data

Operating voltage	10.5 ... 15 V DC
Current consumption	max. 1.250 mA
Contact load relay	max. 30 V DC/1 A or 48 V DC/0,5 A
Ambient temperature	-10 °C ... 50 °C
Storage temperature	-25 °C ... 75 °C
Air humidity	< 95 % (non-condensing)
Weight	approx. 150 g
Dimensions	W: 150 mm H: 82 mm D: 20 mm
Declaration of Performance	DoP-20615130701



Whether or not a connection is possible must be individually checked in advance by the technical sales department.

Accessories

788612	Loop isolator PCB
788600	Housing surface mount, gray
788601	Housing flush mount, gray
788650.10	Housing surface mount, white
788651.10	Housing flush mount, white
788605	Mounting kit

808631.10

esserbus transponder RZT, 12 V



Same as 808630.10, but rated voltage is 12 V DC, not configurable.

Technical Data

Operating voltage	10.5 ... 13.8 V DC
Current consumption	max. 1.250 mA
Contact load relay	max. 30 V DC/1 A or 48 V DC/0,5 A
Ambient temperature	-10 °C ... 50 °C
Storage temperature	-25 °C ... 75 °C
Air humidity	< 95 % (non-condensing)
Weight	approx. 150 g
Dimensions	W: 150 mm H: 82 mm D: 20 mm
Declaration of Performance	DoP-20615130701

Accessories

788612	Loop isolator PCB
788600	Housing surface mount, gray
788601	Housing flush mount, gray
788650.10	Housing surface mount, white
788651.10	Housing flush mount, white
788605	Mounting kit

Accessories for esserbus Transponders

788612

Loop isolator for transponder



Loop isolator PCB to be mounted on esserbus transponders. To isolate short circuit failure and wire break on the loop.

Technical Data

Ambient temperature	-20 °C ... 50 °C
Storage temperature	-20 °C ... 75 °C
Air humidity	< 95 % (non-condensing)
Type of protection	IP 50 (with housing)
Weight	approx. 10 g
Dimensions	W: 32 mm H: 20 mm D: 10 mm
Declaration of Performance	DoP-20611130701

808624

EOL-O terminating device



The EOL-O terminating device is mounted on the last control input device in the detector zone and is used to monitor alarm signaling devices.

Features

- Used for monitoring of control outputs with conventional alarm signaling devices being connected
- Additionally recognizes creeping interruptions and short-circuits
- Loop monitoring in compliance with EN 54-13

808625

EOL-Z module for detector groups



Terminating device for the monitoring of standard inputs when using esserbus transponders (Part No. 808623, 808622, 808619.10). The zener diode is sealed in the housing of the end-of-line (EOL) module.

808626

EOL-I terminating device



The EOL-I terminating device is mounted on the last device in the detector zone and is used to monitor detector zone inputs.

Features

- Used for monitoring of detector zone inputs with standard fire detectors being connected
- Additionally recognizes creeping interruptions and short-circuits
- Loop monitoring in compliance with EN 54-13

808626.10

EOL-UV terminating device (UniVario)



The terminating element EOL-UV is used for standard-compliant monitoring of flame and heat detectors of product family UniVario. The EOL-UV will be connected to the base of the UniVario detector.

 For transponder Part No. 808623.10

Features

- Used for monitoring of detector zone inputs with standard fire detectors being connected
- Additionally recognizes creeping interruptions and short-circuits
- Loop monitoring in compliance with EN 54-13

804870

Alarm and monitoring module for IQ8FCT XS, IQ8FCT LP



An external, monitored contact can be connected to the terminals of the IQ8FCT XS or LP. In case of contact activation, the address and the programmed additional text of the corresponding IQ8FCT XS or LP will be displayed.

 The max. cable length to the connected module must not exceed 500 meters!

Technical Alarm Modules

804868

IQ8TAL with isolator, 1 contact IN/1 OUT



Features

- One contact input and one floating relay output
- Voltage supply via the field bus
- Test and reset function
- Higher IP55 protection with Part No. 704965
- Programmable inverse monitoring functionality of the contact input (1k resistance latent/10k resistance fire)
- Powered by the FACP
- Total cable length of the external contact up to 500 m
- Integrated loop isolator
- Max. 127 transponder TAL electronic modules per analog loop

Approval: VdS

The technical alarm device IQ8TAL is a fully-fledged loop device of the IQ8Control fire detection system and facilitates the detection and forwarding of technical alarms.

The IQ8TAL is equipped with an integrated loop isolator, a contact input and a relay output. An external NO or NC may be connected to a single IQ8TAL. When an alarm is triggered the address and the programmed additional text of the IQ8TAL to which the contact is connected are displayed automatically. The integrated relay can be optionally configured as a normally-closed contact or as a normally-open contact. The IQ8TAL does not need a separate voltage supply.

In order to increase the IP protection class, the optional IP 55 protection kit (Part No. 704965) can be used.

The functionality of the IQ8TAL can be tested with the included key and the alarm status can be reset directly at the device.

Technical Data

Quiescent current @ 19 V DC	approx. 45 µA
Contact load relay	30 V DC/AC/1 A
Operation indicator	green LED
Alarm display	red LED
Connection terminal	max. 2.5 mm ² (AWG 26-14)
Application temperature	-20 °C ... 70 °C
Storage temperature	-30 °C ... 75 °C
Air humidity	< 95 % (non-condensing)
Type of protection	IP 43, IP 55 with cover 704965
Housing	PC/ASA plastic
Color	blue, similar to RAL 5015
Weight	approx. 110 g
Dimensions	W: 88 mm H: 88 mm D: 21 mm W: 88 mm H: 88 mm D: 57 mm (with surface-mounted housing)
Declaration of Performance	DoP-20792130701



Please note that for surface mounting, the mount housing (Part No. 704981) must be ordered separately.
Compatible with all IQ8Control systems with firmware V3.08 and tools 8000 V1.14 or superior.



2 x 10 k (terminating), 1 x 1 k (alarm), 1 x 6.8 k (inverse operation)

Accessories

704965 Protective kit for MCP and TAL, transparent

704981 Surface mount housing for small MCP, blue

704981

Surface mount housing for small MCP and TAL, blue, similar to RAL 5015



Blue, for small design electronic modules. Cable entry requires cable glands 704147, 704148.

704965

Protective kit for MCP and TAL, transparent

Transparent, suitable for small MCPs. The cover serves as a protection to prevent inadvertent activation and to protect from high humidity.



Technical Data

Type of protection	IP55
--------------------	------



Cover and two neoprene seals

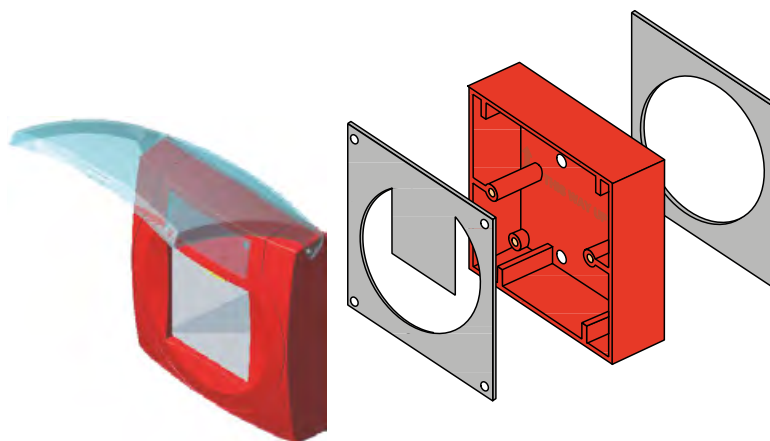

1

2

3

4

5

6

7

8

9

10

11

12

13

14

Notes

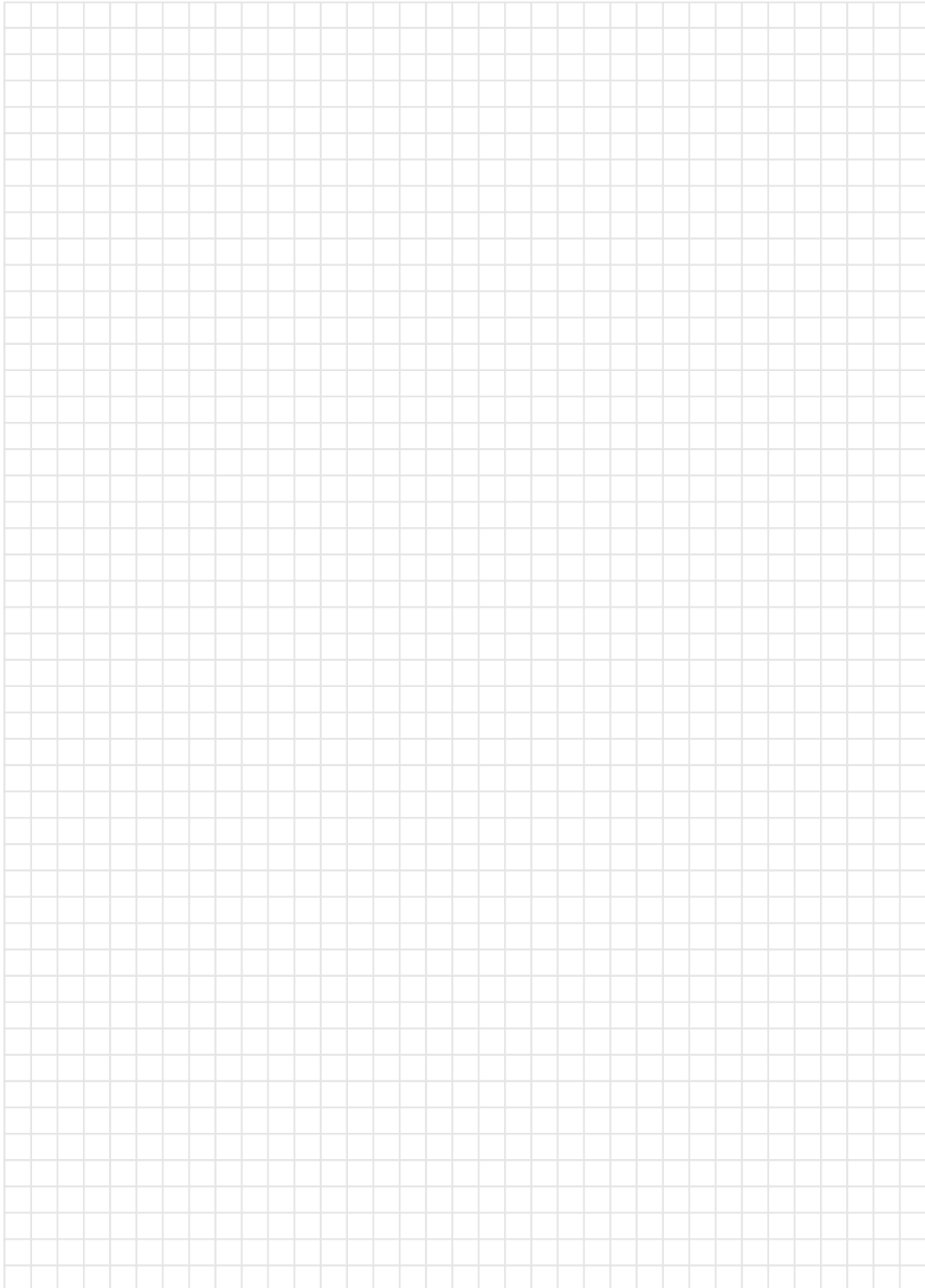



Wireless Components

Wireless Modules

134-140

Features

- Radiocommunication transmission features
- Interference-proof transmission via dual band with frequency hopping @ 433 MHz and 868 MHz
- Bi-directional data traffic
- Permanent automatic interference monitoring of transmission path
- In case of interferences, automatic modification of frequency band and radiocommunication channel
- Band blocking detection
- High transmission range (in the open air: max. 300 m)
- Automatic interference detection due to low field strength levels

The following wireless modules are only compatible with IQ8Control panel. Communication between the RF devices is set up via a dual band transmission mode. The RF-technology applies frequency hopping to enable highest transmission security. In case of interference, the frequency band and the radiocommunication channels are automatically modified. If the entire band and the receiver are blocked due to high interference level, a fault signal is transmitted to the fire alarm panel. Thus, secure and reliable wireless transmission is provided. The transmission range in open air is up to 300 m. Inside the building, the transmission range varies, depending on building structure, wall thickness or use of reinforced concrete.

IQ8Wireless radio technology facilitates the cable-free connection of IQ8Quad automatic fire detectors (with and without alarm signaling devices), manual call points and the IQ8Alarm alarm signaling device to the IQ8Control fire alarm system.

Already existing fire alarm systems can be expanded using the wireless technology or complete fire alarm systems can be realized for smaller objects with wireless components as well. The allocation of the wireless components to a wireless transponder or wireless gateway takes place via the tools 8000 programming software.

The status of the batteries is checked automatically and their necessary replacement is displayed early on as a detector failure on the FACP and/or the wireless transponder*.

The optimal installation site as well as the maximum possible transmission distance can be conveniently and quickly transmitted via the tools 8000 integrated field strength measurement.

* during allocation of the wireless components via wireless transponder

 Please take into account that the use of wireless components requires extra training, covering project planning and commissioning. For further information see our training brochure.

These devices were designed, produced and labeled for operation within the countries of the European Union (EU) in accordance with the current EU standards and requirements. In case the device is installed outside of the EU, national guidelines and requirements must be taken into consideration.

For further information, please contact your local sales representative.

Using components like IQ8Alarm and IQ8Quad with integrated alarm devices the esserbus PLus is needed.

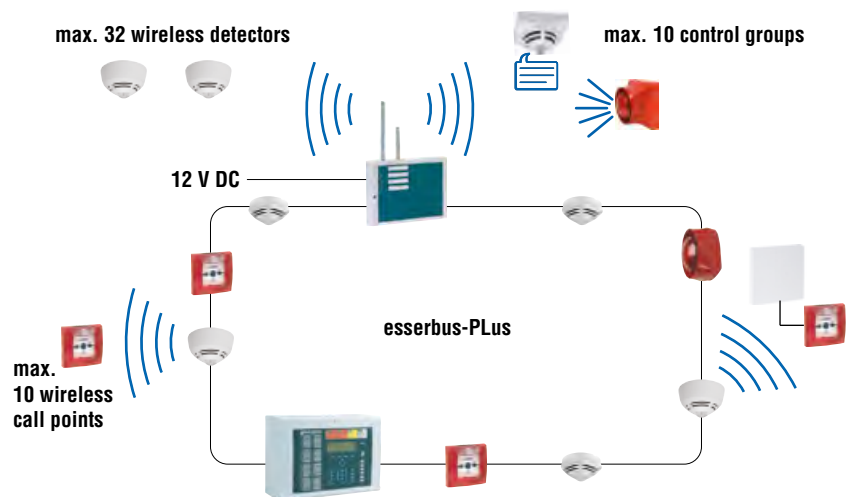

Connection example

805593.10

IQ8Wireless detector base

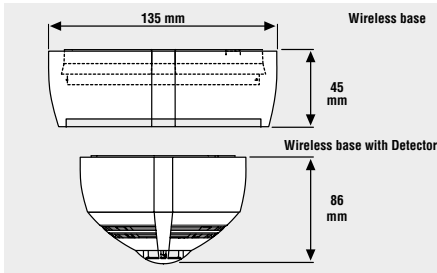

Features

The wireless detector base suitable for

- Fixed heat detector (Part No. 802171, 802177)
- Rate-of-rise heat detector (Part No. 802271, 803271)
- Optical smoke detector (Part No. 802371, 803371)
- O²T multisensor fire detector (Part No. 802374, 803374)
- OTG multisensor fire detector (Part No. 802473)

The wireless detector base features

- Individual detector identification on the control panel
- Regular functionality check for each detector
- Alarm and operation display on the detector
- Alarm and fault transmission in accordance with EN 54-2
- Easy detector or battery replacement with detector removal tool
- Fault signal when the mounted wireless base and the inserted detector are removed
- Permanent monitoring of battery voltage
- Up to 2 years battery life depending on detector type and environmental conditions

Approval: VdS

With the IQ8Wireless base, the wireless component is located in the base onto which the respective fire detector is placed. The wireless base facilitates the connection of the IQ8Quad TM, TD, O, O²T and OTG detectors via a wireless transmission line to the esserbus/esserbus-PLus and integrates them via wireless transponder or wireless gateway into the fire alarm system. A maximum of 32 radio bases per wireless transponder and/or 10 per radio gateway can be allocated.

Technical Data

Operating voltage	4 x 3.6 V batteries
Current consumption	approx. 50 µA
Battery operating time	approx. 3 years*
Range inside	max. 30 m
Range outside	max. 300 m
Frequency band 1	433 MHz with 16 channels
Frequency band 2	868 MHz with 7 channels
Data transmission speed	19.2 Kbit/s
Application temperature	-5 °C ... 55 °C
Storage temperature	-20 °C ... 70 °C (w/o batteries) 15 °C ... 35 °C (with batteries)
Air humidity	< 95 % (non condensing)
Type of protection	IP 42
Material	ABS-V0
Color	white, similar to RAL 9010
Weight	approx. 315 g (incl. batteries)
Specification	EN 54-18:2005/-25:2008
Dimensions	Ø: 135 mm H: 49 mm (with detector H: 88 mm)
Declaration of Performance	DoP-20622130701

 The batteries to be used are components of the device approval according to EN 54 and are specified by the manufacturer. With the IQ8Wireless radio components, only the approved batteries with Part No. 805597 may be used. Use of batteries other than those specified by us automatically voids the product's device approval (VdS-approval) and may not be used for example in Germany in fire alarm systems under legal building regulations.

*The battery operating time is dependent on the type of detector/device used, as well as the application temperature and additional surrounding conditions. It can be substantially restricted by increased current consumption of the wireless devices in the case of alarm, wireless interference or poor transmission, or even possibly through contact resistance at the contacts. Please note important instructions for usage of batteries in manual Part No. 798941.10 (available at the website).

 4 x 3.6 V lithium batteries (Part No. 805597)

Accessories

805597 4 x 3.6 V lithium batteries

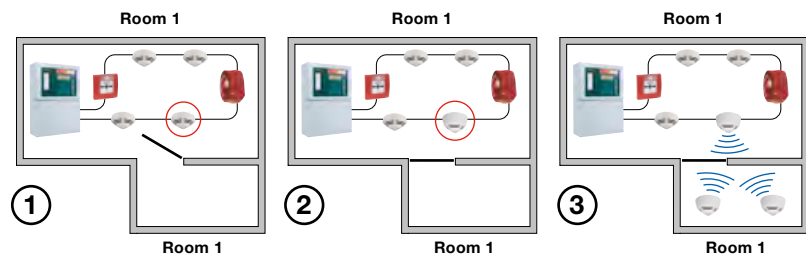

Expansion via IQ8Wireless gateway with IQ8Wireless detector base

805594.10

IQ8Wireless gateway for devices

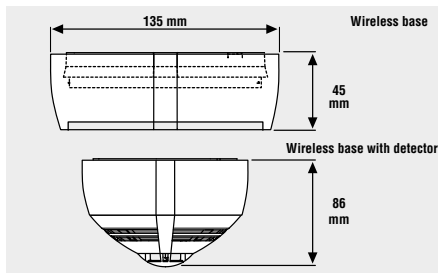

Features

- The wireless gateway can be mounted between detector base and IQ8Quad detector. No additional wiring required
- Suitable for IQ8Quad detectors w/o alarm devices
- The connection of an remote LED indicator for this detector is possible
- Wireless communication with up to 10 users
- Maximum 10 wireless bases
- Maximum 10 wireless interfaces with IQ8MCP manual call points
- Maximum 10 control groups for wireless interface with IQ8Quad/IQ8Alarm alarm signaling devices
- All wireless devices are integrated as individually addressable on the esserbus / esserbus-PLus
- esserbus integration of all radiocommunication devices as individually addressable users
- The radiocommunication devices can be allocated in up to 10 detector zones
- Up to 9 wireless gateways per loop
- Alarm and trouble transmission in accordance with EN 54-2
- Easy detector or battery replacement via detector removal tool
- Trouble signal when removing the gateway and the detector
- Permanent monitoring of battery voltage
- One gateway requires one loop address
- The total number of loop devices of the loop will be reduced by only 12 devices for each connected IQ8Wireless Gateway
- Max. 18 IQ8Wireless Gateways per FACP IQ8Control C
- Max. 45 IQ8Wireless Gateways per FACP IQ8Control M and FACP FlexES Control

Approval: VdS

This wireless gateway is especially designed for convenient and time-saving expansion of an already existing IQ8Control/FlexES Control fire detection system. By removing a detector already installed on the loop and adding the wireless gateway to the standard IQ8 detector base, up to 10 additional fire detectors equipped with wireless detector bases or 10 addressable manual call points can be added to the existing system. Up to 10 components with alarm signaling functions – IQ8Alarm alarm signaling devices and/or IQ8Quad fire alarms with integrated alarm signaling device – can be connected per wireless gateway via the universal wireless interface. And all this without any additional cabling. Depending on the surrounding conditions, the wireless transmission can reach up to 200m. The wireless gateway must fundamentally be operated with an IQ8Quad detector. It integrates the intelligent IQ8Wireless components into the esserbus or esserbus-PLus via the wireless base or wireless interface, thus making these components fully individually addressable loop devices.

Up to 9 wireless gateways can be operated on the loop. Each wireless gateway reduces the maximum number of esserbus devices by 12 pieces.

Technical Data

Operating voltage	8 ... 42 V DC (via loop)
Voltage supply	4 x 3.6 V lithium battery
Current consumption	400 µA to max. 2,5 mA
Battery operating time	approx. 3 years*
Range inside	max. 20 m
Range outside	max. 200 m
Frequency band 1	433 MHz with 16 channels
Frequency band 2	868 MHz with 7 channels
Transmitter power	10 mW
Sensitivity	-100 dBm
Data transmission speed	19,2 Kbit/s
Application temperature	-5 °C ... 55 °C
Storage temperature	-20 °C ... 70 °C (w/o batteries) 15 °C ... 35 °C (with batteries)
Air humidity	< 95 % (non-condensing)
Type of protection	IP 42
Material	ABS
Color	white, similar to RAL 9010
Weight	approx. 265 g (incl. batteries)
Specification	EN 54-17:2005/-18:2005/-25:2008
Dimensions	Ø: 135 mm H: 49 mm (with detector H: 88 mm)
Declaration of Performance	DoP-20620130701

 The standard detector base version IQ8Quad 805590 is not included in the RF gateway package.

The batteries to be used are components of the device approval according to EN 54 and are specified by the manufacturer. With the IQ8Wireless radio components, only the approved batteries with part no. 805597 may be used. Use of batteries other than those specified by us automatically voids the product's device approval (VdS-approval) and may not be used for example in Germany in fire alarm systems under legal building regulations.

*The battery operating time is dependent on the type of detector/device used, as well as the application temperature and additional surrounding conditions. It can be substantially restricted by increased current consumption of the wireless devices in the case of alarm, wireless interference or poor transmission, or even possibly through contact resistance at the contacts. Please note important instructions for usage of batteries in FB 798941.

 4 x 3.6 V lithium batteries (Part No. 805597)

Accessories

805597 4 x 3.6 V lithium batteries

805595.10

IQ8Wireless transponder for devices, wall mount

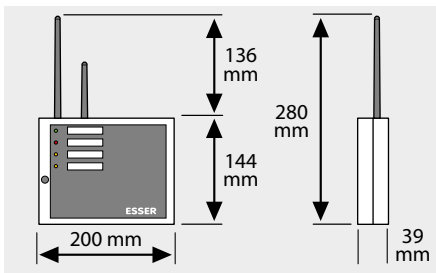

Approval: VdS

This wireless transponder is designed for wall mounting. The wireless transponder communicates with up to 32 other wireless devices. These can be wireless of various types from intelligent automatic fire detectors or wireless interfaces with manual call points and/or alarm signaling devices of the IQ8-family. Using the System IQ8Control/FlexES Control, the wireless transponder integrates the intelligent automatic detectors (with and without alarm signaling devices), manual call point and alarm generator IQ8Alarm in the esserbus / esserbus-PLus via the wireless base and/or wireless interface. The detector base allows esserbus integration of intelligent automatic detectors as bus devices with individual addressing via the transponder. Up to 10 transponders can be operated on one loop. The transponder can be linked with the loop as well as with a conventional detector zone or it can be operated as a stand-alone unit. Potential-free outputs for common fault and common fire are available. For system 8000 the transponder for RF devices can only be connected by using a potential-free relay to 4 IN/2 OUT or 1 IN transponder, because it is not compatible with panel 8000 and it cannot be used as a bus device.

The transponder needs an external supply voltage for operation.

Features

- RF communication with up to 32 users
- maximum 32 wireless bases
- maximum 10 wireless interfaces with IQ8MCP manual call points
- maximum 10 control groups for wireless interface with IQ8Quad/IQ8Alarm alarm signaling devices
- esserbus integration of all RF. Devices as individually addressable users
- The RF devices can be assigned in up to 32 detector zones
- Alarm and fault transmission in accordance with EN 54-2
- Connection to esserbus of IQ8Control panel as bus device as well as to a conventional detector zones
- Stand-alone operation
- Potential-free outputs for common fault and common fire

Technical Data

Operating voltage	9 ... 30 V DC (via loop)
Quiescent current @ 12 V DC	approx. 17 mA
Alarm current @ 12 V DC	approx. 18 mA
Range inside	max. 30 m
Range outside	max. 300 m
Frequency band 1	433 MHz with 16 channels
Frequency band 2	868 MHz with 7 channels
Data transmission speed	19,2 Kbit/s
Contact load relay	30 V DC/1 A
Application temperature	-5 °C ... 55 °C
Storage temperature	-10 °C ... 60 °C
Air humidity	< 95 % (non condensing)
Type of protection	IP 42
Housing	ASA + PC
Color	white, similar to RAL 9010
Weight	approx. 250 g
Specification	EN 54-17:2005/-18:2005/-25:2008
Dimensions	W: 200 mm H: 280 mm D: 39 mm (with detector H: 88 mm)
Declaration of Performance	DoP-20621130701

 The external power supply of the IQ8Wireless transponder can come from the FACP or from an external power unit.

The voltage for the wireless transponder can be supplied by the FACP or an external power supply. An individual, separately protected supply line must be installed for the voltage supply. The external voltage supply is monitored by the wireless transponder. If the wireless transponder is installed as a device on the IQ8Control/FlexES Control, fire system, analog loop, a disturbance is transmitted to the fire detection control unit via the loop and is indicated there.

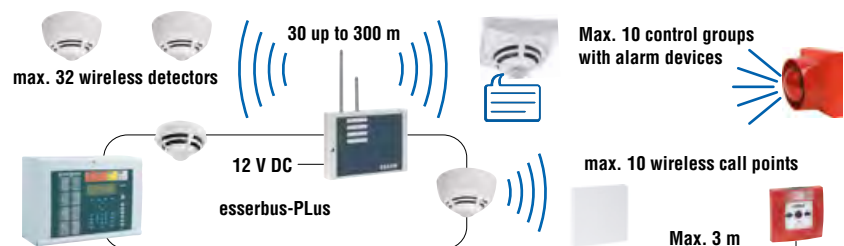

805601.10

IQ8Wireless universal interface w/o cover, red



Features

Radio interface suitable for:

- IQ8MCP - electronic module, large design (Part No. 804905/ 804906)
- IQ8MCP – complete package, small design (Part No. 804971)
- IQ8MCP - electronic module, small design (Part No. 804955), only with mounting frame (Part No. 704967)
- IQ8Quad detectors (with and without alarm signaling devices)
- IQ8Alarm alarm signaling device (Part No. 8073xx)

Radio interface features:

- The IQ8 components are individually identified on the FACP
- Regular functionality performance checks of IQ8 components
- Fault signal when the IQ8 components are removed from the FACP
- Operating mode display directly at the IQ8 manual call point and IQ8Quad detector
- Alarm and fault message transmission in compliance with EN 54-2
- Easy detector removal and battery replacement using multi-functional key
- Remote operation of IQ8 components possible (max. 3 meters) via 2-wire line
- Constant battery status monitoring
- Early battery replacement notification at the FACP

Approval: VdS

The radio interface allows the IQ8MCP (small or large design) to be connected on the wireless esserbus-PLus.

The radio interface connects the intelligent IQ8MCP to the esserbus/powered loop via the IQ8Wireless transponder or the IQ8Wireless gateway. Thus, the devices are automatically converted into individually addressable loop devices.

Technical Data

Operating voltage	4 x 3.6 V batteries
Current consumption	approx. 30 µA
Battery operating time	approx. 3 years*
Range inside	max. 30 m
Range outside	max. 300 m
Frequency band 1	433 MHz with 16 channels
Frequency band 2	868 MHz with 7 channels
Data transmission speed	19,2 Kbit/s
Application temperature	-5 °C ... 55 °C
Storage temperature	-20 °C ... 70 °C (w/o batteries) 15 °C ... 35 °C (with batteries)
Air humidity	< 95 % (non-condensing)
Type of protection	IP 42
Material	PC/ASA plastic
Color	red, similar to RAL 3020
Weight	approx. 285 g (incl. batteries, without attachment)
Specification	EN 54-18:2005/-25:2008
Dimensions	W: 135 mm H: 135 mm D: 20 mm (without attachment)
Declaration of Performance	DoP-20623130701

Only use small manual call points with mounting frame Part No. 704967.

 The batteries to be used are components of the device approval according to EN 54 and are specified by the manufacturer. With the IQ8Wireless radio components, only the approved batteries with Part No. 805597 may be used. Use of batteries other than those specified by us automatically voids the product's device approval (VdS-approval) and may not be used for example in Germany in fire alarm systems under legal building regulations.

*The battery operating time is dependent on the type of detector/device used, as well as the application temperature and additional surrounding conditions. It can be substantially restricted by increased current consumption of the wireless devices in the case of alarm, wireless interference or poor transmission, or even possibly through contact resistance at the contacts. Please note important instructions for usage of batteries in in manual Part No. 798941.10 (available at the website).

 4 x 3.6 V lithium batteries (Part No. 805597)

Accessories

704967 Mounting frame for small MCP

805603 IQ8Wireless-mounting frames for IQ8Alarm

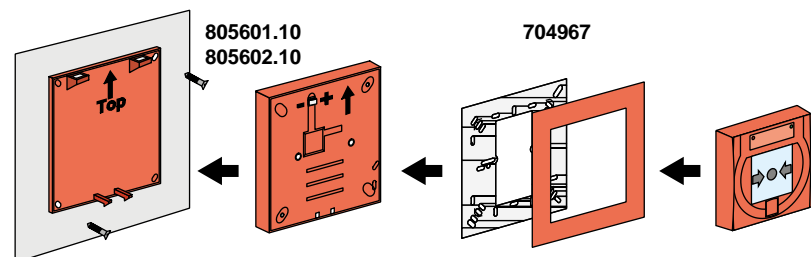

Application example for large MCP

805602.10

IQ8Wireless universal interface w/o cover, white

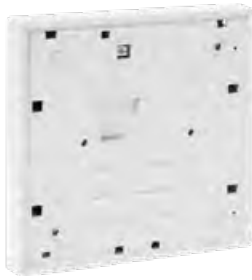

Approval: VdS

As 805601.10, but white color.

Accessories

704967 Mounting frame for small MCP

805603 IQ8Wireless-mounting frames for IQ8Alarm

805604 IQ8Wireless-mounting frames for IQ8Quad

704967

Mounting frame for small MCP, red and white



The mounting frame is useful for mounting MCPs on different international flush mount boxes.

Technical Data

Color	red, similar to RAL 3020 white, similar to RAL 9010
Dimensions	W: 132 mm H: 132 mm D: 8 mm

 2 x Fastening screws are included (red and white)

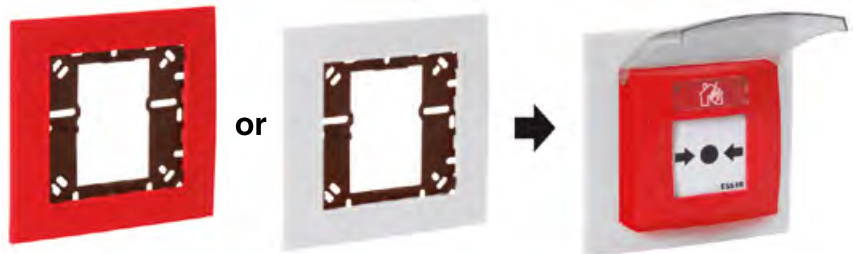

Application example: Mounting frame with small MCP

805603

IQ8Wireless mounting frames for IQ8Alarm, red and white



The mounting frame is used for the mounting of the IQ8Alarm alarm signaling devices onto the IQ8Wireless interface Part No. 805601.10/805602.10.

Technical Data

Color	red, similar to RAL 3020 white, similar to RAL 9010
Weight	approx. 64 g
Dimensions	W: 133 mm H: 133 mm D: 21 mm

 1 x mounting frame red
1 x mounting frame white

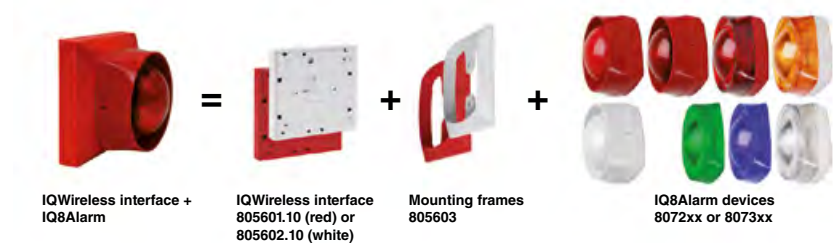

Application example

805604

IQ8Wireless mounting frame for IQ8Quad detectors, white



The mounting frame is used for the mounting of the IQ8Quad fire detector with or without integrated alarm signaling device onto the IQ8Wireless interface 805602.10.

Technical Data

Color	white, similar to RAL 9010
Weight	approx. 41 g
Dimensions	W: 133 mm H: 133 mm D: 21 mm



IQ8Wireless interface + IQ8Quad detector with integrated alarm device

IQ8Wireless interface 805602.10

Mounting frame 805604

Standard detector base 805590

IQ8Quad detector with integrated alarm device 80238x

Application example

805605

IQ8Wireless cover for wireless interface, red and white



For applications in which the IQ8 components are not to be directly mounted (remote connection) on the IQ8Wireless interface Part No. 805601.10/805602.10, the wireless interface can be used with the filler panel.

Technical Data

Color	red, similar to RAL 3020 white, similar to RAL 9010
Weight	approx. 33 g
Dimensions	W: 133 mm H: 133 mm D: 8 mm

-  1 x Red cover plate
- 1 x White cover plate

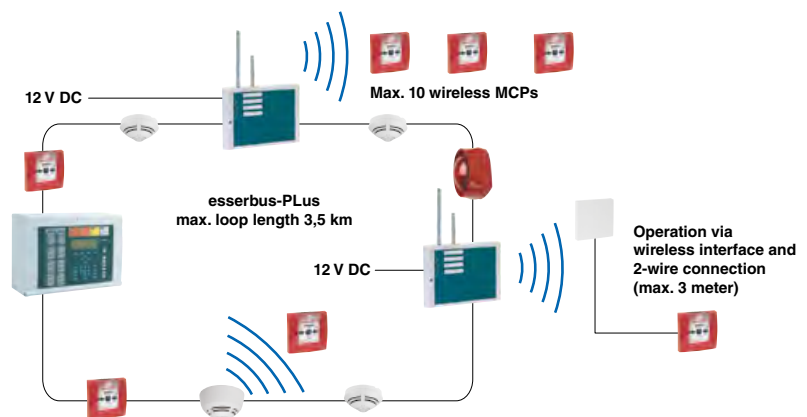

Application example

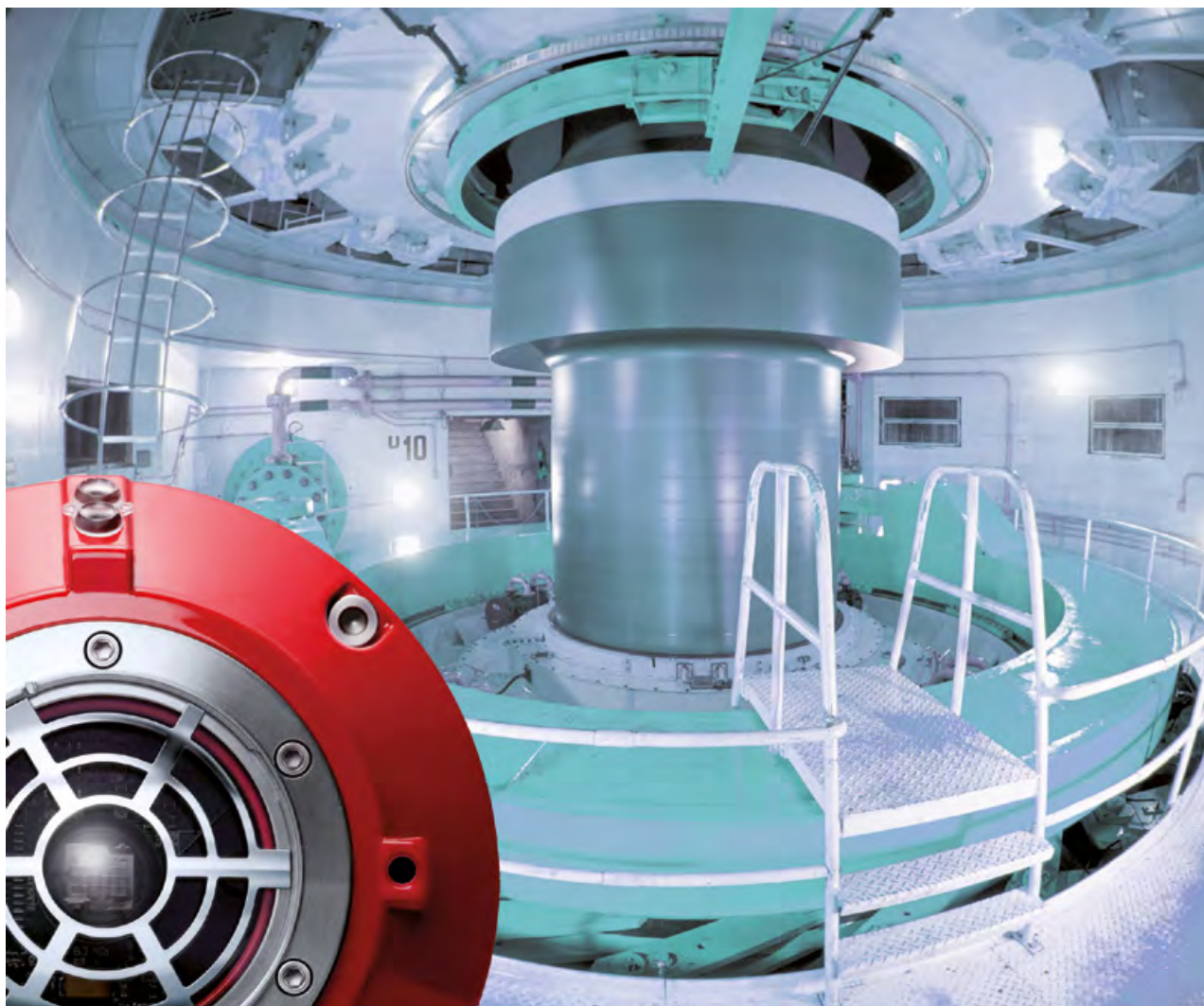

Detectors for Special Applications

Flame and Heat Detectors

142-149

Air Duct Detectors

150-152

Linear Heat Detectors

153-159

Linear Smoke Detectors

160-167

Aspirating Smoke Detectors

168-187

Flame Detectors

782311

UV flame detector UniVario



Features

- Direct linking and voltage supply via standard detector group at the esserbus transponder (Part No. 808623.10)
- Base installation and alignment via mounting bracket (Part No. 783312)
- High IP protection for indoor and outdoor usage
- Operation and fault status displayed on the detector
- Self-monitoring via internal sensors
- Easy testing with magnet via integrated reed switch

Approval: VdS

UV flame detector for the recognition of fast developing fires with flame formation. Operation, fault and fire statuses are displayed via LEDs on the detector. The supply voltage and the linking take place directly via the standard detector zone at the esserbus transponder (part no. 808623.10). Resetting of the detector is also carried out directly via the same esserbus transponder.

Technical Data

Operating voltage	9 V DC
Quiescent current @ 9 V DC	approx. 500 µA
Alarm current @ 9 V DC	typ. 15 mA
Area to be monitored	max. 676 m ²
Height to be monitored	max. 45 m
Ambient temperature	-20 °C ... 80 °C
Storage temperature	-40 °C ... 85 °C
Air humidity	< 95 % (non-condensing)
Type of protection	IP 67
Housing	Die cast aluminum
Color	red, similar to RAL 3000
Weight	approx. 945 g (incl. base and bracket)
Dimensions	W: 130 mm H: 140 mm D: 92 mm
Declaration of Performance	DoP-20567130701



Detector base and mounting bracket are not supplied!

782315

Three-channel infrared flame detector UniVario



Features

- Direct linking and voltage supply via standard detector group at the esserbus transponder (Part No. 808623.10)
- Base installation and alignment via mounting bracket (Part No. 783312)
- 3-channel infrared flame detector
- High level of protection against disturbance variables thanks to optimized hardware and development of special algorithms
- Maximum level of response sensitivity according to EN54-10, Class 1
- Each optical channel has separate functional monitoring
- Easy testing with magnet via integrated reed switch

Approval: G 211041

UniVario three-channel IR flame detector for recognition of quickly developing fires with flame development. Optical windows of the IR sensors are fully monitored. The detector achieves a high level of resistance towards disturbance variables via three-channel infrared evaluation. Voltage supply and connection occur directly via the standard detector zone at the esserbus transponder (Part No. 808623.10). The detector is also reset directly via the same esserbus transponder.

Technical Data

Operating voltage	9 V DC
Quiescent current	approx. 3.5 mA
Alarm current @ 9 V DC	typ. 21.8 mA
Area to be monitored	max. 676 m ²
Height to be monitored	max. 45 m
Ambient temperature	-20 °C ... 80 °C
Storage temperature	-40 °C ... 85 °C
Air humidity	0 ... 95 % (non-condensing)
Type of protection	IP 67
Housing	Die cast aluminum
Color	red, similar to RAL 3000
Weight	approx. 991 g (incl. base and bracket)
Dimensions	W: 130 mm H: 140 mm D: 92 mm
Declaration of Performance	DoP-21055130701



Detector base and mounting bracket are not supplied!

Heat Detectors

782310



Features

- Direct linking and voltage supply via standard detector group at the esserbus transponder (Part No. 808623.10)
- Base installation and alignment via mounting bracket (Part No. 783312)
- Microcontroller functional monitoring of heat sensors as well as software and hardware
- Quick fire detection with high level of protection against false alarms
- Comparison to typical false variables using intelligent evaluation algorithms
- High level of electromagnetic compatibility
- Various mounting possibilities
- Oil-tight and high level IP 67 protection class as well as resistance to impact and vibration

Heat detector UniVario

Approval: G 211039

For detection of open fires with fast development of heat. For usage in polluted industrial environments, interior and exterior areas. Voltage supply and connection occur directly via the standard detector zone at the esserbus transponder (Part No. 808623.10). The detector is also reset directly via the esserbus transponder.

Technical Data

Operating voltage	9 V DC
Quiescent current	approx. 0.15 mA
Alarm current @ 9 V DC	typ. 15 mA
Response temperature	0 °C ... 90 °C
Ambient temperature	-20 °C ... 80 °C
Storage temperature	-40 °C ... 85 °C
Air humidity	< 95 % (non-condensing)
Type of protection	IP 67
Housing	Die cast aluminum
Color	red, similar to RAL 3000
Weight	approx. 995 g (incl. base and bracket)
Dimensions	W: 130 mm H: 140 mm D: 85 mm
Declaration of Performance	DoP-21053130701



Detector base and mounting bracket are not supplied!

782302



Heat detector UniVario, 200 mm

Approval: G 211040

Same as 782310, but with sensor rod length of 200 mm.

Technical Data

Quiescent current	approx. 0.25 mA
Response temperature	54 °C ... 400 °C
Weight	approx. 1 kg
Declaration of Performance	DoP-21054130701



Detector base and mounting bracket are not supplied!

782306

Heat detector UniVario, 2 m



Same as 782310, but with sensor tube for installation in areas with poor accessibility such as shafts and canals.

Technical Data

Response temperature	54 °C ... 400 °C
Weight	approx. 1.3 kg



Detector base and mounting bracket are not supplied!

782307

Heat detector UniVario, 6 m

Same as 782306, but with sensor tube length of 6 m.

Technical Data

Weight	approx. 1.4 kg
--------	----------------



Detector base and mounting bracket are not supplied!

782308

Heat detector UniVario, 9 m

Same as 782306, but with sensor tube length of 9 m.

Technical Data

Weight	approx. 1.5 kg
--------	----------------



Detector base and mounting bracket are not supplied!

Accessories

783312

Mounting bracket for UniVario flame detectors



Mounting bracket for alignment of the industrial flame detectors UniVario. Simple installation with base Part No. 783313.

783313

Standard base UniVario



Standard detector base for detectors of the UniVario product family.

Technical Data

Weight	approx. 350 g
Dimensions	W: 130 mm H: 140 mm D: 36 mm

Features

- Simple detector exchange via standard base principle
- Fast installation via simple plug-in
- Generous space for cabling for user-friendly installation

Intrinsically Safe Flame Detectors

FS24X-911-23-6



Features

- Patented WideBand IR™ technology
- Patented Electronic Frequency Analysis™
- Visible sensor for optimum false alarm rejection
- Selectable detection sensitivities
- Field-of-View: 90° cone-of-vision
- Dual microprocessors for reliable performance
- Real-time clock for accurate time dating of events
- FirePic™ — pre-fire event data storage
- Event log with date and time stamp
- RS-485 ModBus communication
- Alarm, Fault and Fire Verification relays
- Automatic Optical Path and Electronic self-test
- Patented Electronics Module for component protection with plug-in terminations for easy field installation
- Two M25 conduit entries
- Low power consumption
- High RFI and EMI immunity
- FM, ATEX, CE mark approvals
- CU-TR approved
- INMETRO approved
- Meets SIL 2 requirements
- Certified to EN54-10:2002
- FM 3260 performance
- Detects hydrocarbon and non-hydrocarbon fuel fires in all environmental conditions
- Wide operating temperature range
- Optimal false alarm rejection
- Minimal maintenance for trouble-free operation
- PC software and interface module (FSIM) for fault diagnostics real-time graphs (RTGs), and downloading of FirePics™ and event log
- Suitable for a wide variety of applications
- Easy electronics module replacement
- Test lamps for manual testing

FS24X-911 3IR AL M25 FM/EN54

The FS24X multi-spectrum Triple IR (IR/IR/IR/Visible) Flame Detector, is one of the FSX family of advanced technology Electro-Optical fire and flame detectors. WideBand IR™, WideBand 4.3 micron IR™, and Visible detection technology with sophisticated software algorithms delivers the highest fire detection performance combined with optimal false alarm rejection. Unlike narrow-band detectors, the WideBand IR™ Infrared technology using high-speed solid-state Quantum sensors allows detection of most types of fires, hydrocarbon and non-hydrocarbon, in all weather conditions.

FS24X - Aluminium, M25, ATEX/IECEX, FM3260, EN54-10.
Advanced true triple IR Flame Detector for Hazardous Industrial areas.

Visual Indicators:

Green LED: Power; Red LED: Alarm; Yellow LED: Fault

Technical Data

Operating voltage	18 ... 32 V DC
Field of view	90° cone-of-vision, ± 45° from on axis
Sensitivity	Very high (60m), high (45m), medium (30m) and low (15m) - switch selectable
Response time	3 ... 5 sec. to 0.1 m2 n-Heptane fire at 30 m 3 ... 10 sec. to 0.1 m2 n-Heptane fire at 60 m
Power Consumption	Operating: 56 mA @ 24 V DC Alarm: 106 mA @ 24 V DC Heater: 155 mA – additional Note: Heater will turn on at -17°C
Output Relays	Fire Alarm: SPDT (NO / NC) – De-energised/energized, latching/non-latching Fault: SPST (NO) – De-energised, latching/non-latching Auxiliary: SPDT (NO / NC) – De-energised/energised, latching/non-latching Contacts rating: 1 amp @ 24 V DC
Analog output	0 ... 20 mA stepped - source or sink user selectable
Loop resistance	50 ... 400 Ohms
Temperature range	Operating: -60°C ... +85°C Storage: -55°C ... +110°C
Vibration	Meets or exceeds MilSpec 810C Method 514.2, Curve AW12
Wiring	2.5 mm2 (14 AWG) to 0.326 mm2 (22 AWG); shielded cable recommended
Conduit entries	Two M25 conduit entries
Dimensions	W: 110.4 mm H: 124.2 mm D: 156.4 mm
Housing	Copper-free powder coated aluminum

 Mounting bracket SM4 and cable glands FSX-25M25 have to be ordered separately.

Accessories

- SM4 Stainless Steel Swivel mounting assembly for FS24X, and FS20X detectors
- PSU-12 Universal charger for Test Lamps and Interface Kits. For 110-240 VAC with international plugs
- TL-2055 IR Test Lamp for testing FSX detectors, explosion proof version. Incl universal charger
- TL-1055 IR Test Lamp for testing FSX detectors, non-explosion proof version. Incl universal charger
- SH-001 Sunshield (316 Stainless Steel)
- FSX-25M25 Cable gland, IP68

FS24X-211-24-6

FS24X-911 3IR SS M25 FM/EN54

As FS24X-911-23-6 but 316 stainless steel.

FS20X-211-23-6



Features

- Patented WideBand IR™ Infrared combined with Ultraviolet
- Detection range greater than 60 m to 0.1 m² heptane fire
- Patented Electronic Frequency Analysis
- Visible sensor for optimum false alarm rejection
- Selectable detection sensitivities
- Solar blind 90° field of view
- Dual microprocessors for reliable performance
- Real-time clock for accurate time dating of events
- FirePic™ — Up to 6 pre-fire event data storage
- Event log — Up to 200 events with date and time stamp
- Built-in RS-485 ModBus communication
- Alarm, Fault and Fire Verification relays
- Automatic Optical Path and Electronic self-test
- Patented Electronics Module for component protection with plug-in terminations for easy field installation
- Two M25 conduit entries
- Low power consumption
- High RFI and EMI immunity
- FM hazardous area approved
- Ex d ATEX /IECEX approved
- CU-TR approved
- INMETRO approved
- Meets SIL 2 requirements
- Certified to EN54-10:2002
- FM 3260 performance
- Detects hydrocarbon and non-hydrocarbon fuel fires in all environmental conditions
- Wide operating temperature range
- Arc welding immunity
- False alarm rejection
- Minimal maintenance for trouble-free operation
- PC software and interface module (FSIM) for fault diagnostics real-time graphs (RTGs), and downloading of FirePics™ and event log
- Suitable for a wide variety of applications

FS20X-211 IR/UV AL M25 FM/EN54

The FS20X is a multi-spectrum UV/Dual IR/VIS fire and flame detector with a proven UV solar-blind sensor. The FS20X detector uses advanced algorithms for signal processing and fire and flame analysis to alarm to most fires in all industrial environmental conditions. If the detector's UV signal is degraded due to heavy smoke or a contaminated lens, the FS20X's patented WideBand IR™, Near Band IR and Visible sensors will still alarm to fire, albeit at a reduced sensitivity and slower response time.

The FS20X detector has a detection range in excess of 60 m (200 feet) (very high sensitivity setting) for the detection of a 0.1m² (one square-foot) n-Heptane reference fire and has a field of view with a greater volumetric coverage than most UV/IR detectors.

FS20X - Aluminium, M25, ATEX/IECEX, FM3260, EN54-10.
Advanced UV/Dual IR/VIS Flame Detector for Hazardous Industrial areas.

Visual Indicators:

Green LED: Power; Red LED: Alarm; Yellow LED: Fault

Technical Data

Operating voltage	18 ... 32 V DC
Field of view	90° Horizontal cone-of-vision, ± 45° from on axis
Sensitivity	Very high (60m), high (45m), medium (30m) and low (15m) - switch selectable
Response time	3 ... 5 sec. to 0.1 m ² n-Heptane fire at 30 m 3 ... 10 sec. to 0.1 m ² n-Heptane fire at 60 m
Power Consumption	85 mA @ 24 V DC
Output Relays	Fire Alarm: SPDT (NO / NC) – De-energised/energized, latching/non-latching Fault: SPST (NO) – De-energised, latching/non-latching Auxiliary: SPDT (NO / NC) – De-energised/energized, latching/non-latching Contacts rating: 1 amp @ 24 Vdc
Analog output	0 ... 20 mA stepped - source or sink user selectable
Loop resistance	50 ... 400 Ohms
Temperature range	Operating: -40 ... +85°C Storage: -55 ... +110°C
Vibration	Meets or exceeds MilSpec 810C Method 514.2, Curve AW12
Wiring	2.5 mm ² (14 AWG) to 0.326 mm ² (22 AWG); shielded cable recommended
Conduit entries	Two M25 conduit entries
Dimensions	W: 110.4 mm H: 124.2 mm D: 156.4 mm
Housing	Copper-free powder coated aluminum



Mounting bracket SM4 and cable glands FSX-25M25 have to be ordered separately.

Accessories

- SM4 Stainless Steel Swivel mounting assembly for FS24X, and FS20X detectors
- PSU-12 Universal charger for Test Lamps and Interface Kits. For 110-240 VAC with international plugs
- TL-2055 IR Test Lamp for testing FSX detectors, explosion proof version. Incl universal charger
- TL-1055 IR Test Lamp for testing FSX detectors, non-explosion proof version. Incl universal charger
- SH-001 Sunshield (316 Stainless Steel)
- FSX-25M25 Cable gland, IP68

FS20X-211-24-6

FS20X-211 IR/UV SS M25 FM/EN54

As FS20X-211-23-6 but 316 stainless steel.

FSL100 Series Flame Detectors

FSL100-IR3



Features

- Indoor & outdoor use
- Zone 2/22 Ex proof
- Hydrocarbon and non-hydrocarbon sources
- Pressure compensation element, avoiding trapped moisture
- Lightweight GRP housing with no grounding required
- Selection of relay set-up with DIP switches
- Ease of installation
- Swivel mounting with fine angle adjustment
- Light Mounting Bracket
- Entry Gland
- Advanced Test Lamp available

IR3 flame detector RED, ATEX FM EN54

Approval: VdS, ATEX

FSL three-channel IR flame detector for recognition of quickly developing fires with flame development. The detector achieves a high level of resistance towards disturbance variables via three-channel infrared evaluation. It is suitable for most light industrial applications, storage areas and machinery. It is simple to install with Wide Field of View Solid 90 degree volume cone (Cone of Vision - Field of View). Has proven exceptional resistance against acids, bases and solvents.

Visual Indicators:

- Continuous green: normal operation
- Continuous yellow: fault
- Flashing yellow: Fault and guide to repeat self-test after a self-test failure
- Continuous red: alarm

Technical Data

Range	max. 30 m alarming @ 10 sec for 0.1 m2 n-heptane fire
Cone-of-vision	90° minimum horizontal and vertical
Operating voltage	10 ... 28 V DC (12 ... 24 V DC nominal)
Start up times	<10 sec
Alarm response time	8 ... 30 sec
Operating current normal @ 24 V DC	approx. 25 mA
Current in alarm @ 24 VDC	approx. 75 mA
Housing	Glass reinforced polyester (GRP), non-incendive. UV resistant, self-extinguishing V-0 (UL-94)
Dimensions	H: 125 mm x W: 80 mm x D: 57 mm
Weight	465 g
Temperature, operating	- 40 °C ... +70 °C
Typ of protection	IP65
Detector specification	EN54-10, FM3260
EC-type examination certificate	ATEX Zone2/22, FM Class 1, 2 & 3 Div2

Accessories

- FS1000-SM21 FSL100 Swivel mount.
- FSL100-TL FSL100 Test lamp, incl. universal charger and carrying case; non EX

FSL100-UV



UV flame detector RED, ATEX FM EN54

As FSL100-IR3, but as UV flame detector.

Technical Data

Range	max. 25 m alarming @ 10 sec for 0.1 m2 n-heptane fire
-------	---

FSL100-UVIR



UV/IR flame detector RED, ATEX FM EN54

As FSL100-IR3, but as UV/IR flame detector.

Accessories for Intrinsically Safe Detectors

SM4

Swivel mount



FSX - Universal Swivel Mount allows simple, robust and accurate mounting and sighting of FSX flame detectors. Supplied in Stainless Steel with angle markings to allow setting detector aiming.

FSX-A001

FSX kit with Interface, RS485,USB cables

Interface kit to enable access to detection logs and FirePics for post event analysis.

TL-1055

Test lamp FS18X/FS20X/FS24X NON-EXP



FSX Safe Area Test Lamp for in-situ testing of flame detectors.

Accessories

FSX-A006 Replacement bulb for TL-1055 and TL-2055

TL-2055

Test lamp FS18X/FS20X/FS24X EXP



FSX Hazardous Area Test Lamp for in-situ testing of flame detectors.

Accessories

FSX-A006 Replacement bulb for TL-1055 and TL-2055

PSU-12

110/220VAC wallcharger test lamp

Charger for FSX test lamp

SH-001

Sun shield SS SS2/SS4/FS24X

FSX Sunshield protects against direct sun.

FSL100-SM21



FSL100 swivel mount

FSL100 Swivel mount enabling simple installation and aiming of the FSL100 range of flame detectors.

FSL100-TL



FSL100 test lamp, charger & case; non EX

FSL100 Safe Area Test lamp to enable simple in-situ testing of the FSL100 range of flame detectors.

Accessories

FSL100-TLBT 12 VDC battery for FSL-TL test lamp

FSL100-TLCH Universal charger for FSL-TL test lamp

1

2

3

4

5

6

7

8

9

10

11

12

13

14

Air Duct Detectors

781463

NEW



Venturi air duct module for IQ8Quad OTblue-LKM

Approval: VdS

Air duct module for usage of the OTblue-LKM multisensor detector IQ8Quad Part No. 802379/800379 or OTblue-LKM multisensor detector ES Detect Part No. 800379 in combination with Venturi tubes Part No. 781466, 781467 or 781468. The kit is mounted outside of the air duct system. The Venturi tube dips into the airflow of the system and conducts the air into the detection chamber and back into the air duct system. During operation, the detector and the alarm LED is visible so that a remote indicator is not required. The housing doesn't need to be opened for maintenance purposes. This can be easily done by using the separate opening in the front of the housing.

Features

- Single-tube air analysis system UG-7 based on the Venturi principle
- Optimum utilization of air flow velocity through new Venturi tube design
- Integrated maintenance opening in the front cover so that air duct smoke detector can be tested
- Suitable for air duct widths from 0.6 to 2.8 m
- Integrated air flow display
- Mounting on round and insulated air duct with mounting kit Part No. 781469

Technical Data

Ambient temperature	0 °C ... 38 °C
Storage temperature	-30 °C ... 75 °C
Type of protection	IP 54
Housing	ABS plastic
Color	gray
Weight	approx. 650 g (w/o base, detector, venturi tube)
Dimensions	W: 165 mm H: 279 mm D: 83 mm

 Please note that the detector must be mounted horizontally! Suitable for monitoring of air duct systems with a minimum diameter of 100 mm. Successor of 781443. According to the product certification, a filter (see our Part No. 781464) is required for the use of the device. This must be ordered separately and is only available as packaging unit.

Accessories

- 781464 Spare filters for weather protection housin
- 781465 Weather protection housing for detector
- 781466 Venturi tube, 0.6 m
- 781467 Venturi tube, 1.5 m
- 781468 Venturi tube, 2.8 m
- 781469 Mounting set for LKM 781463
- 781470 Cable glands M20 f. weather protection housing

 2 x cable glands M20 with nut, 1 x tube end cap, mounting screws included. Without OTblue-LKM detector, detector base, Venturi tube and filter cartridge.

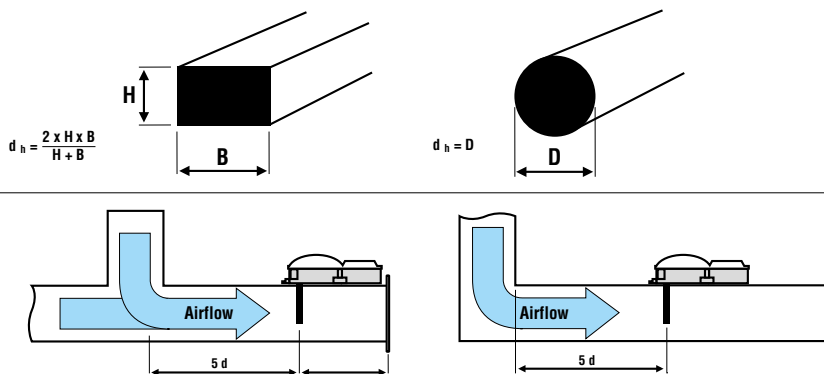

Application example with detector

Accessories

802379

OTblue-LKM multisensor fire detector IQ8Quad with isolator



Approval: VdS

Specially addressable IQ8Quad multisensor fire detector with integrated optical sensor and heat sensor and enhanced false alarm management. For application as air duct smoke detector in venturi air duct modules Part No. 781443. The optical measurement chamber is provided with a patented developed sensor technology using a high-sensitive blue LED (instead of the commonly used red LED in Optical smoke detectors), enabling the detection of open fires, smoldering fires and fires with high heat generation.

Especially for open fires, the classical ionization technology implemented in ionization detectors is replaced by the unique detection technology, unlike ionization detectors, this sensor works without a radioactive element which causes problems at the time of refuse disposal. The detector is capable of identifying the TF1 and TF6 test fires described in the EN 54-9:1982 specification. Well suited for sensitive environment, detection of invisible up to large aerosols.

The OTblue multisensor is an intelligent detector with time-related signal analysis, signal correlation of the sensor data, decentralized intelligence, automatic function self-test, CPU failure mode, automatic adaptation to environmental conditions, alarm and operating data memory, alarm indicator and soft-addressing.

The detector is provided with an integrated isolator and a parallel detector indicator can be connected.

Technical Data

Operating voltage	9 ... 42 V DC
Quiescent current @ 19 V DC	approx. 50 µA
Quiescent current @ FACP battery	approx. 200 µA @ 27,5 V approx. 280 µA @ 42 V
Air speed	1 ... 20 m/s
Application temperature	-20 °C ... 50 °C
Storage temperature	-25 °C ... 75 °C
Air humidity	< 95 % (non condensing)
Type of protection	IP 43 (with base + option)
Housing	ABS plastic, white, similar RAL 9010
Weight	approx. 110 g
Detector specification	EN 54-7
Specification	EN 54-7/-17, CEA 4021
Dimensions	Ø: 117 mm H: 62 mm (incl. base)
Declaration of Performance	DoP-20116130701

 Only suitable for application in air duct construction set 781443.

Accessories

- 805590 Standard detector base for IQ8Quad
- 805591 Detector base with relay contact for IQ8Quad

781464

Spare filter for air duct detector UG7

NEW



For use in unclean and dusty environmental conditions.

 10 pcs

781466

Venturi tube, 0.6 m

NEW



Venturi tube 0.6 m for application with air duct detector module Part No. 781463, length between 140 mm and 600 mm.

 Required borehole in the duct: 38 mm

781467

Venturi tube, 1.5 m

NEW



Venturi tube 1.5 m for application with air duct detector module Part No. 781463, length between 600 mm and 1.400 mm.



Required boreholes in the duct: 38 mm below and 50 mm above. The plastic gasket is included in the scope of delivery of the Venturi air duct module.



Venturi tube and rubber seal

781468

Venturi tube, 2.8 m

NEW



Venturi tube 2.8 m for application with air duct detector module Part No. 781463, length between 1.400 mm and 2.700 mm.



Required boreholes in the duct: 38 mm below and 50 mm above. The plastic gasket is included in the scope of delivery of the Venturi air duct module.



Venturi tube and rubber seal

781469

Mounting set for LKM 781463

NEW



Mounting set for Part No. 781463 for circular and/or insulated air ducts.



Plastic gasket and rubber seal

781465

Weather protection housing for air duct detector

NEW



Protects the air duct detector in difficult environmental conditions such as usage outside and in cold areas to avoid condensation from hot outlet air. The weather protection housing can be subsequently fixed above the already mounted air duct module UG7.

Technical Data

Type of protection	IP 54
--------------------	-------



Opened condition

781469

Mounting set for LKM 781463

NEW



Mounting set for Part No. 781463 for circular and/or insulated air ducts.



Plastic gasket and rubber seal

781470

Cable glands M20 f. weather protection housing

NEW



For additional sealing of cable entry and ensuring the IP type of protection.



5 pcs.

Honeywell DTS Detector



Features

- Multicolor LCD display
- LED indicators: Alarm, Measurement, Fault, Operation
- Temperature measurement and monitoring via fiber-optic sensor cable (Part No. 970150.IN or 970153.IN)
- 1, 2 or 4 measurement channels per evaluation unit
- Loop or open line sensor cable topology
- Up to 256 independent alarm zones per channel
- Up to 10 km sensor cable for each channel
- Laser power below 20 mW
- 10 seconds measurement cycles
- Spatial resolution 0.5 m
- 44 Relay interface, optionally Modbus IP/RTU
- Bidirectional, full digital integration with ESSER by Honeywell fire alarm systems

Approval: VdS, UL, ATEX, IECEx

DTS (Distributed Temperature Sensing) System is capable of detecting fires and accurately locate spots of the fire. The system allows to precisely measure, locate and signalize already small differences of temperature changes by measuring and highlighting temperature of a specific spot vs. environment. Fire resistant (PH category) sensing cable is capable to take signals also during a fire, even when temperatures are up to 750°C (max. two hours). That allows to monitor the progress of fire and supervise fire rescue action accordingly.

The system can work as a standalone system or be easily integrated into existing management platforms (e.g. SCADA systems) by either communicating directly over Ethernet (TCP/IP) using SCPI (standard commands for programmable instruments) or Modbus (IP or RTU).

Technical Data

Operating voltage	10 ... 30 V DC
Power consumption	approx. 17 W @ 20 °C ambient temperature
Operating temperature	-10 °C ... 60 °C
Storage temperature	-40 °C ... 80 °C
Air humidity	< 95 % (non condensing)
Type of protection	IP30
Weight	approx. 9 kg
Dimensions	W: 448 mm H: 88 mm D: 364 mm 2 HU, 19"

970120.IN

Line heat detector Honeywell DTS - evaluation unit, distance range 1 km

Evaluation unit in a 19" rack mount housing.

970121.IN

Line heat detector Honeywell DTS - evaluation unit, distance range 2 km

As 970120.IN, but with a 2 km detection range.

970123.IN

Line heat detector Honeywell DTS - evaluation unit, distance range 4 km

As 970120.IN, but with a 4 km detection range.

970124.IN

Line heat detector Honeywell DTS - evaluation unit, distance range 6 km

As 970120.IN, but with a 6 km detection range.

970126.IN

Line heat detector Honeywell DTS - evaluation unit, distance range 8 km

As 970120.IN, but with a 8 km detection range.

970125.IN

Line heat detector Honeywell DTS - evaluation unit, distance range 10 km

As 970120.IN, but with a 10 km detection range.

970134.IN

Wall mount housing IP66 for Honeywell DTS detector



Approval: VdS, UL, ULC

Alternative IP66 wall mount housing with window for 97012X.IN rack housings.

Technical Data

Operating temperature	-10 °C ... 60 °C
Storage temperature	-40 °C ... 80 °C
Air humidity	< 95 % (non condensing)
Type of protection	IP66
Weight	approx. 17 kg
Dimensions	W: 400 mm H: 500 mm D: 150 mm
Specification	EN54-22 (VdS) / UL 521 and ULC-S530

 4 x Pflitsch UNI Dicht cable glands

Accessories

970129.IN

License Modbus TCP/IP interface

Features

- Modbus TCP slave
- Full temperature trace
- Trace index
- Timestamp
- Alarm status
- Zone temperature values (max., min. and avg.)

970130.IN

2 sensor channels for Honeywell DTS detector

The DTS evaluation unit is delivered as one channel device as a standard. By ordering 970130.IN the evaluation unit can be expanded by one additional channel. Two channel option enables to make a redundant loop.

970132.IN

4 sensor channels for Honeywell DTS detector

The DTS evaluation unit is delivered as one channel device as a standard. By ordering 970132.IN the evaluation unit can be expanded by three additional channel. Four channel option enables to make a full redundant loop.

970133.IN

ATEX, IECEx certification for Honeywell DTS detector

970166

DTS evaluation unit warranty extension from 1 to 3 years

Extended warranty extends the standard warranty period to 3 years. Warranty is applicable to one evaluation unit purchased together with the warranty. One warranty always covers one evaluation unit.

970167

DTS evaluation unit warranty extension from 1 to 5 years

As 970166 but with a 5 year period.

970138

Relay controller set for Honeywell DTS detector



If the application requires driving more than the embedded 44 relay outputs of Honeywell DTS detector, the relay controller set should be used. The set is capable of controlling up to 256 additional relay outputs per channel. Each relay output can be assigned flexibly to any defined alarm condition.

Technical Data

Operating voltage	24 V DC
Current consumption @ 24 V DC	approx. 350 mA (Controller)
Ambient temperature	0 °C ... 55 °C
Storage temperature	-25 °C ... 85 °C
Air humidity	5% to 95% (non condensing)
Weight	approx. 200 g
Dimensions	W: 55 mm H: 100 mm D: 70 mm (Controller)

- 1 x power supply
- 1 x pre-programmed relay controller
- 1 x digital output module
- 1 x end module
- 8 x relays with accessories for easy wiring

970137



Relays extension set for Honeywell DTS detector



The Relays Extension Set adds another digital output module and 8 relays. For example, to offer 48 additional relays, 1 relay controller (Part No. 970138) and 5 Relays Extension Sets are necessary.

Technical Data

Operating voltage	24 V DC
Current consumption @ 24 V DC	approx. 25 mA (each IO card/relay)
Ambient temperature	0 °C ... 55 °C
Storage temperature	-25 °C ... 85 °C
Air humidity	5% to 95% (non condensing)





-  1 x Digital output module
-  8 x Relays output with accessories for easy wiring

970139

High dense I/O connection set with connection block



Cable connection set to connect 19" housing evaluation unit relay outputs with fire alarm system.



-  1 x input cable, D-Sub 9, 150 cm
-  1 x 9 pin connection box
-  2 x output cable, D-sub 44, 150 cm
-  2 x HD connection block

970139.IN

High dense I/O connection set with open end



Cable connection set to connect evaluation unit in 19" or wall-mounted housing relay outputs with fire alarm system.

-  1 x input cable, D-Sub 9, 370 cm
-  2 x output cable, D-sub 44, 290 cm

Sensor Cables for Honeywell DTS Detector

970150.IN

FO sensor cable Safety FRNC

Fast responding sensor cable with tight buffered fiber. Compact dimensions, high flexibility and good bending behaviour. High tensile strength by Aramid yarns. The cable has a halogen-free and flame-retardant cable sheath.



Technical Data

Explosion protection	ATEX 1 GD, 111/112
Material	FRNC outer sheath, Aramid fibers, tight-buffered fibers
Weight	approx. 17 kg /km



Sensor cable will be delivered in requested length.

970151

Sensor cable connectors for FO sensor cable 970150.IN

To reduce deployment cost and time, we are optionally offering preassembled pig tails. This enables quick and easy onsite installation, with no need to organize a fusion splicer, splice box to get the sensing cable connected to the DTS detector. Pig tails are supplied with E2000 8° angled connectors. For safe transportation and installation the connectors and pig tails are covered by a flexible tube to ensure proper protection.



2x Connectors

970153.IN

FO sensor cable Steel FRNC

Fast responding sensor cable armoured, with stainless steel loose tubes and outer sheath. High permissible tensile strength, high crush resistance. Longitudinally and laterally watertight. Excellent rodent protection. The cable has a halogen-free and flame retardant cable sheath.



Technical Data

Explosion protection	ATEX 1 GD, 111/112
Material	FRNC outer sheath, stainless steel wires, gel-free stainless steel loose tube, fibres with primary coating
Weight	approx. 29 kg /km



Sensor cable will be delivered in requested length.

970154

Sensor cable connectors for FO sensor cable 970153.IN

As 970151, but for FO sensor cable steel FRNC (Part No. 970153.IN).

970146.IN

Micro splice-box IP20 for Honeywell DTS sensor cables



The splice box should only be used indoors and is suitable for cables with a diameter of max. 7.5 mm.

Technical Data

Type of protection	IP20
Material	thermoplastic PC-ABS, non-halogen, flame retardant
Dimensions	W: 100 mm H: 160 mm D: 30 mm



1 x splice cassette with splice holder

Features

- 2 cable inlets with sealing grommets

970147.IN

Splice-box IP67 for Honeywell DTS sensor cables



For indoor or outdoor use.

Technical Data

Type of protection	IP67
Material	Aluminum, coated gray
Dimensions	W: 82 mm H: 128 mm D: 57 mm



1 x splice cassette with splice holder

Features

- 3 cable inlets with PG cable glands

970148

Double head cable ties, 500 pcs



970151.IN

Sensor cable heating testing tool



The testing tool is used to verify functionality of the sensor cable according to regional requirements.

Electronic boards control the heating sleeves to simulate a fire condition along the fiber-optic sensor cable. Protection devices are built-in for safe operation. Electrical connections are carried out by flexible cables, which are protected against mechanical damages by a resistant outer jacket. The flexible cables have specific plugs for easy connection to the control circuit.

It is possible to use this tool without disassembling the installed mounting brackets (when the distance is at least 1m).

Technical Data

Power supply	230 V AC, 50 Hz
Current consumption @ 24 V DC	max. 1.5 mA
Power consumption	max. 350 W
Weight	approx. 1 kg (control unit) approx. 2 x 1 kg (heating sleeves)
Dimensions	W: 350 mm H: 170 mm D: 440 mm (carrying case) W: 160 mm H: 80 mm D: 240 mm (control unit)

Features

- 4 LEDs: e.g. Power supply ON, fault signal
- Integrated timer (1 to 10 min)
- User friendly operation
- Work with all fiber-optic cables

970154.IN

E2000 APC 8° pigtail, 5 m



E2000 8° angled connectors with a 5 m pigtail offered to splice the sensing cables.

970165.IN

Cutting tool for FO steel sensor cable 970153.IN



Recommended to cut the stainless steel tube, to properly remove the cable sheath and splicing the pigtail to the sensing fiber.

Dowels for Honeywell DTS Detector

970140.IN

Plastic clamp set (100 pc.) - dowels in zinc-plated steel



Features

- For indoor and outdoor applications
- Applicable for dynamic loads
- UV-stabilized: 5 times better than PA6/PA66
- Very low moisture absorption
- High chemical resistance
- Halogen free as per IEC-Norm 754-2

Self-locking plastic cable clamps with zinc-plated steel anchor, ideal for installation on concrete walls and ceilings. With this mounting solution the sensor cable is fast and securely installed. This plastic cable clamp provides excellent resistance against corrosive and chemical atmospheres as well as an uncritical characteristic relating to fire (halogen free). The plastic cable clamp in combination with the metal free cable is especially suitable for use in rail tunnels where metal free components are often required.

To fix the clamps on the concrete a special concrete dowel type is used. The metal dowel is an anchor made of steel, which is placed into a drilled hole and anchored by deformation-controlled expansion. The anchor may be deployed in structures subject to dry internal conditions and also in structures subject to external atmospheric exposure in humid internal conditions or in other particularly aggressive conditions e.g. immersion in seawater, chloride atmosphere or atmosphere with chemical pollution (e.g. in desulphurization plants or road tunnels where de-icing materials are used).

Technical Data

Ambient temperature	-40 °C ... 110 °C
Type	K6 x 30/15
Material	polyamide (clamp), zinc plated steel (anchor)
Color	dark grey, similar to RAL 7001(clamp)
Dimensions	Ø: 6 mm L: 61 mm (metal anchor)

 Please note: for mounting of the anchor, one anchor setting tool (Part No. 970144.IN) is necessary and is not included in delivery.
Other anchor lengths on request.

-  100 x plastic clamps
- 100 x anchor
- 1 x SDS drill

970142.IN

Plastic clamp set (100 pc.) - dowels in stainless steel



As 970140.IN but with stainless steel anchor.

Technical Data

Type	K6 x 30/15
Material	stainless steel (anchor)
Dimensions	Ø: 6 mm L: 61 mm (metal anchor)

-  100 x plastic clamps
- 100 x anchors
- 1 x SDS drill

970143.IN

Steel clamp set (100 pc.) - dowels in zinc-plated steel

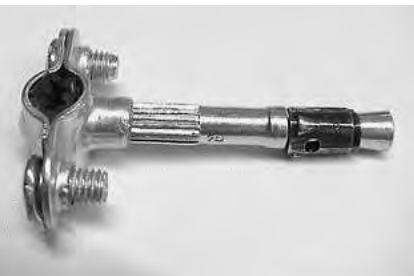

As 970140.IN but with steel clamp, protected by rubber. The steel clamp complies with DIN 3016. No anchor setting tool required.

Technical Data

Material	steel zinc plated with rubber protection (clamp)
----------	--

-  100 x steel clamps
- 100 x anchors
- 1 x SDS drill

970145.IN

Stainless steel clamp set (100 pc.) - dowels in stainless steel

As 970143.IN but in high grade corrosion resistant stainless steel variant.

970144.IN

Anchor setting tool



To fix the metal anchor it is necessary to have one setting tool. Required for 970140.IN and 970142.IN only.

 1 x setting tool

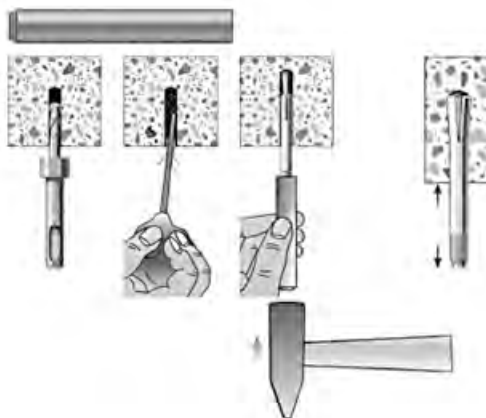

1

2

3

4

5

6

7

8

9

10

11

12

13

14

Fireray

761315



Features

- Compact housing
- Range 5 m to 50 m
- Robust construction
- Complies with EN 54-12 standard
- Monitoring and resetting is carried out via the esserbus transponder 808623 during loop operation

Fireray 50 RV with one prism

Approval: VdS

The detector consists of an integrated infrared transmitter and receiver. The signal is reflected by a prism and analysed by the receiving element. Signal reaching the threshold will trigger an alarm.

Integration on the loop and the resetting function is carried out via the esserbus transponder 808623.

Integration on conventional line requires use of a reset module. The detector requires a separate voltage supply of 24 V DC.

The Fireray is installed approx. 0.3 to 0.8 m underneath the ceiling and its reflector with the same ceiling distance opposite. There should be no reflecting obstacles in the transmission zone (approx. 2 degrees).

Technical Data

Operating voltage	10.2 ... 30 V DC
Quiescent current @ 24 V DC	approx. 4 mA
Alarm current @24 V DC	approx. 15 mA
Contact load	max. 30 V DC / 1 A
Range	5 to 50 m
Ambient temperature	-20 °C ... 55 °C
Storage temperature	-35 °C ... 60 °C
Air humidity	0% ... 93%, (non-condensing)
Type of protection	IP50
Housing	ABS plastic, flame resistant
Color	gray, similar to RAL 7035
Weight	approx. 670 g
Detector specification	EN 54-12
CE certificate	0786-CPD-20045
Dimensions	W: 210 mm H: 117 mm D: 120 mm

 1 prism 761322

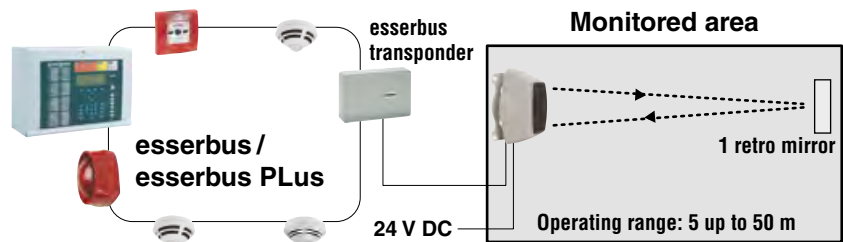

Application example

761316



Fireray 100 RV with four prisms

As 761315, but with four prisms and max. operating range of 100 m.

 4 prisms 761323

761317

Fireray 5000, line smoke detector, incl. controller, 100 m



Approval: VdS, LPCB, UL

The Fireray 5000 combines an infrared transmitter and receiver in one detector head. The transmission signal is reflected by a prism and analyzed on smoke concentration by the receiving unit. The transmitting/receiving unit contains an electric actuator which always keeps the IR-ray in the optimal orientation.

Electric actuator in detector head allows for remote manual alignment via remote controller and its LCD display, keypad and laser indicator. The automatic, self-alignment mechanism keeps detector head perfectly aligned with reflective prism regardless of vibrations or building construction movement.

Features

- Remote system controller
- LASER assisted alignment
- Automatic contamination compensation
- Automatic IR beam path alignment
- Electric remote detector head orientation adjustment

Technical Data

Operating voltage	14 ... 28 V DC
Quiescent current @ 24 V DC	approx. 10 mA
Current consumption	8 mA ... 12 mA (niedrigen Strom-Modus typ 10)
Alarm current @ 24 V DC	approx. 50 mA
Contact load	100 mA / 30 V DC
Range	8 ... 100 m
Ambient temperature	-20 °C ... 55 °C
Storage temperature	-40 °C ... 85 °C
Type of protection	IP54

 4 prisms 761322+761323

761317.50

Fireray 5000, line smoke detector, incl. controller, 50 m



As 761317, but with a 50 m detection range.

Technical Data

Range	8... 50 m
-------	-----------

 1 prism 761322

Reflectors and Accessories

 The individual reflectors and reflector sets can also be used with the Fireray products. However, please observe the additional planning information in the relevant functional descriptions.

761401.10





Reflector set for LRMX, for ranges of up to 80 m

Metal reflector set for different types of linear smoke detectors. Suitable for ranges of up to 80 m.

Technical Data

Range	5 ... 80 m
Dimensions	W: 370 mm H: 370 mm D: 7 mm

 Suitable for all lines of supplied beam detectors.

 Steel plate: 4 x reflector 761403

761402.10





Reflector set for LRMX, for ranges of up to 100 m

Metal reflector set for range extension of LRMX up to 100 m.

Technical Data

Range	5 ... 100 m
Dimensions	W: 370 mm H: 370 mm D: 7 mm

 Reflector sets also available on request with water-repellent reflectors Part No. 761413 (nano coating) or additional built-in heating. Suitable for all lines of supplied beam detectors.

 Steel plate: 9 x reflector 761403

761403

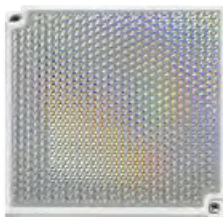

Single reflector for LRMX

Replacement prism – single reflector for usage with the line smoke detector (Part No. 761400.10).

Technical Data

Range	5 ... 40 m
Dimensions	W: 100 mm H: 100 mm

 Suitable for all lines of supplied beam detectors.

761317.H



Fireray 5000 detector head

Additional detector head for Fireray 5000 (761317).

761317.50.H

Fireray 5000 detector head

Additional detector head for Fireray 5000 (761317.50).



761312

Ceiling pendant mount for Fireray

Ceiling pendant mount for F2000, F5000, F50RV, F100RV and universal bracket 761314



Technical Data

Weight approx. 3.4 kg

761314

Univ. bracket for F5000 or prism plate 761440/761441

Universal bracket for a F5000 detector head or prism plate 761440 or 761441



Technical Data

Weight approx. 300 g

761440

Plate for 1 prism

Prism plate for 1 prism for use with bracket 761314

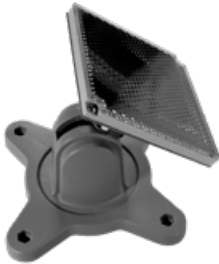

Technical Data

Weight approx. 150 g

 Prism and bracket are not included!

761441

Plate for 4 prism

Prism plate for 4 prisms for use with bracket 761314

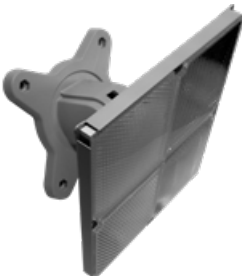

Technical Data

Weight approx. 300 g

 Prisms and bracket are not included!

1
2
3
4
5
6
7
8
9
10
11
12
13
14

761404.10



Ceiling holder for LRMX, for distances from 40 to 70 cm

For better mounting of the line smoke detector (Part No. 761400.10) on walls, girders, ceilings and beams. The ceiling bracket is made of aluminum and can be adjusted in length anywhere from 40 to 70 cm. A high-grade ball joint mounting bracket is located on the top side for easy wall/ceiling mounting. The ceiling bracket is suitable for attaching the mounting plate Part No. 761406.

Technical Data

Weight approx. 2.3 kg



Ceiling bracket incl. mounting material for the aluminum holder but does not include material for mounting of the holder on ceilings, walls or beams.

Features

- For easy ceiling and wall mounting in compliance with DIN VDE 0833-2
- Optimal alignment of detector and reflectors under difficult ambient conditions via ball joint mounting bracket
- Extendable ceiling bracket for flexible adjustment of length for distances of 400 to 700 mm
- Invisible cable routing inside the ceiling
- Capacity 25 kg
- Swivel hinge approx. 180°
- Ball joint approx. 90° and holding fixture for prism reflector
- RAL 9010 (pure white) surface

761405.10

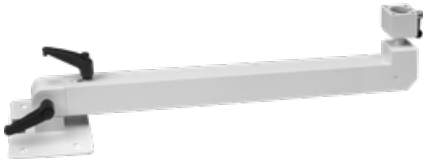

Ceiling holder for LRMX, for distances from 70 to 150 cm

Same as 761404.10 but extendable for ceiling clearances from 70 to 150 cm.

Technical Data

Weight approx. 3.3 kg

761406



Mounting plate for ceiling bracket for detector/single reflector

Mounting plate made of aluminum for attaching the line smoke detector Part No. 761400.10 or the prism reflector Part No. 761403 on the ceiling bracket.

761407



Mounting spider for ceiling bracket

Mounting spider for the ceiling brackets (Part No. 761404.10 and 761405.10) for alternative attachment of the reflector sets (Part No. 761401.10 and 761402.10) on the ceiling bracket.

Open-area Smoke Imaging Detection (OSID)



Features

- Patented dual wavelength, UV & IR, particle detection
- High immunity to dust, fogging, steam, reflections and object intrusion
- High tolerance to vibration and structural movement
- Easy alignment with large adjustment and viewing angles
- Simple installation, commissioning and maintenance
- Simple DIP switch configuration
- 3D volumetric coverage
- Maximum detection range up to 150 meters
- 3 levels of sensitivity possible (35%, 45%, 60%)

The linear smoke detector OSID using dual wavelength detects only repeatable absolute smoke obscuration values, while rejecting the presence of dust particles or solid intruding objects. This is already provided using the simplest configuration – one imager and one emitter. One imager can work with up to seven emitters.

An optical imaging array in the OSID detector provides a wider viewing angle to locate and capture images. Consequently, the system is easier to install and align and can compensate for drift caused by natural shifts in building structures.

In addition, OSID requires only limited space (15 - 20 cm) in its line of view. Therefore, the solution can be deployed safely between ceilings and supporting structures, moving cranes, etc.

Each component can be mounted directly to the surface or can be secured with the supplied mounting brackets.

Imager	Field of View		Detection Range				Max. Number of Emitters
	Horizontal	Vertical	Standard Power		High Power		
			Min	Max	Min	Max	
10°	7°	4°	30 m (98 ft)	150 m (492 ft)	--	--	1
45°	38°	19°	15 m (49 ft)	60 m (197 ft)	30 m (98 ft)	120 m (393 ft)	7
90°	80°	48°	6 m (20 ft)	**34 m (111 ft)	12 m (39 ft)	**68 m (223 ft)	7

** Maximum Distances measured for the Center Field of View of the Imager. For more details on distances for the Imager, see the OSID Product Guide.

Technical Data

Operating voltage	20 ... 30 V DC
Range	< 150 m
Alignment angle	-60° ... 60° (h), -15 ... 15° (v)
Ambient temperature	-10 °C ... 55 °C
Air humidity	10 ... 95 % (non-condensing)
Type of protection	IP44 (electronic) IP66 (optical housing)
Weight	approx. 651 g
Detector specification	EN 54-12
Dimensions	W: 198 mm H: 130 mm D: 96 mm

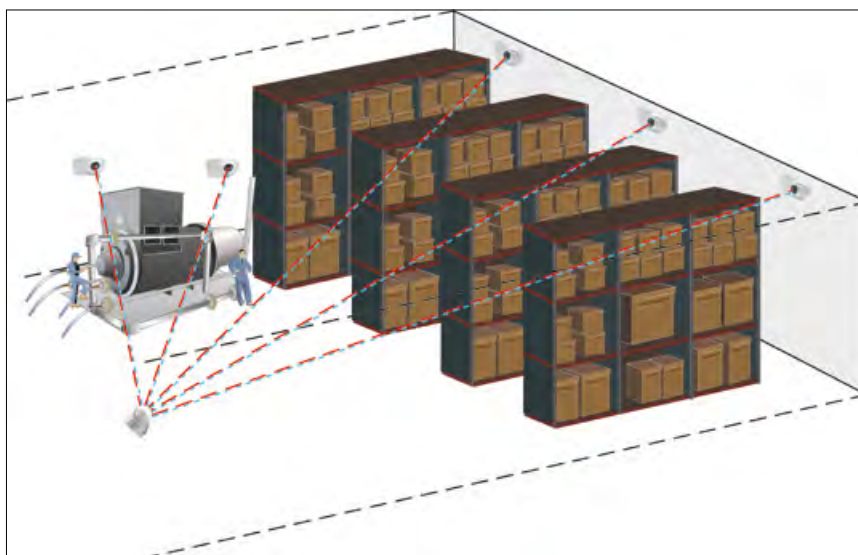

OSI-10

OSID Imager - 7° coverage

Features

- Field of view coverage: horizontal 7°, vertical 4°

Approval: G211072

Imager for use with OSID emitter.
Image sensor / receiver for smoke detection for open spaces, evaluation. Two light sources (IR and UV), optical filters, high-speed image capture and intelligent software algorithms to increase the noise immunity and safety from erroneous / false alarms, 1 light source can be connected, via sensors and DIP switch individually configurable.

Technical Data

Current consumption @ 24 V DC	approx. 8 mA @ 1 imager, 10 mA @ 7 imagers
Weight	approx. 610 g

Accessories

ISID-INST OSID Installation Kit
 OSE-SP-01 Emitter standard power, battery version
 OSE-SPW Emitter standard power, wired at 24 V DC
 OSE-HPW Emitter high power, wired at 24 V DC

OSI-90

OSID Imager - 80° coverage

As OSI-90, but with field of view coverage: horizontal 80°, vertical 48°.

OSE-SP-01

OSID Emitter standard power, battery version

Features

- Built-in 5 year battery

The emitter produces two light sources (UV / IR) which are evaluated by an OSID imager. The built-in battery lasts 5 years.

Technical Data

Weight	approx. 1.2 kg
Dimensions	W: 130 mm H: 198 mm D: 96 mm

Accessories

761310 OSID Installation Kit
 761300 Imager - 7° Coverage, 24 V DC
 761302 Imager - 80° Coverage, 24 V DC

OSE-SPW

OSID Emitte standard power, wired at 24 V DC

As OSE-SP-01, but wired.

Technical Data

Current consumption @ 24 V DC	approx. 0,35 mA
Weight	approx. 535 g

OSE-HPW

OSID Emitter high power, wired at 24 V DC

As OSE-SPW, but with high powered emitter.

Technical Data

Current consumption @ 24 V DC	approx. 0,8 mA
-------------------------------	----------------

ISID-INST

OSID installation kit

The installation kit is used for commissioning and maintenance of the OSID smoke detector.



- 1 x Laser alignment tool
- 1 x Test filter
- 1 x PC cable
- 1 x Cleaning cloth
- 1 x Manual

OSID-EHE

IP66 housing for OSID standard light source (emitter)



Technical Data

Ambient temperature	-25 °C ... 60 °C
Type of protection	IP66 , IK 07
Material	ABS
Dimensions	W: 241 mm H: 194 mm D: 127 mm

OSID-EHI

IP66 housing for OSID image sensor (imager)



Technical Data

Ambient temperature	-25 °C ... 60 °C
Type of protection	IP66 , IK 07
Material	ABS
Dimensions	W: 241 mm H: 194 mm D: 127 mm

1

2

3

4

5

6

7

8

9







10

11

12

13

14

	FAAST LT-200	VESDA-E				VESDA LASER		
		VEU	VEP		VES	VEA	VLF 250/500	Industrial VESDA VLI
			VEP 1-pipe	VEP 4-pipe				
								
Application Areas	Use in a variety of applications such as raised floor and false ceiling areas, storage areas and room surveillance in relatively clean areas	An extra high sensitivity range for the detection of very small amounts of smoke e.g. in data centers.	Earliest fire detection with the best possible false alarm suppression for a variety of applications such as public buildings, storage areas, halls, atriums, hospitals, power plants, etc.	Very early fire warning with the best in class dust rejection for data centers, warehouses, airports, clean rooms, large atriums, etc.	Targeted addressability with asuperior sensitivity to that of a point detector.	Earliest fire detection for a variety of applications such as telecommunication areas, control cabinets, room surveillance in relatively clean areas	Difficult and industrial environmental conditions	
Pipes and Area Coverage								
Pipe Length (Linear)	2 x 100 m	4 x 100 m	1 x 100 m	4 x 70 m	4 x 70 m	40 x 100 m	1 x 25 / 50 m	1 x 120 m
Pipe Length (Branched)	2 x 160m	800 m	130 m	560 m	560 m	4000 m	30 / 60 m	360 m
Area Coverage	1 600 m ²	6 500 m ² *	1 000 m ²	2 000 m ²	2 000 m ²	2 000 m ² across 40 sample holes	250 / 500 m ²	2 000 m ²
No. of Pipe Inlets	2 / channel	4	1	4	4	40	1	4
Multiple Pipe Addressability	per channel	No	No		Up to 4	Up to 40	No	No
Sensitivity								
Min Fire 1 Threshold	0.07% obs/m	0.001% obs/m	0.01% obs/m		0.01% obs/m	1.6% obs/m	0.025% obs/m	0.15%/m
Detection Range	0.07 - 6.5% obs/m	0.001 - 20.0% obs/m	0.005 - 20% obs/m		0.005 - 20% obs/m	0.020 - 16% obs/m	0.025 - 20% obs/m	0.005 - 20.0% obs/m
EN54-20 (Class A/B/C)								
Max. no of Holes Class A	3 / channel	80	30	40	40***	40**	12 / 30	24
Max. no of Holes Class B	6 / channel	80	40	80	80***	40**	12 / 30	28
Max. no of Holes Class C	18 / channel	100	45	100	100***	40**	12 / 30	60
Additional								
IP Rating	IP65	IP40	IP40		IP40	IP40	IP30	IP66

* System design and regulatory requirements may restrict the monitoring area to a lesser amount

** Check local codes for the required transport times determined by the tube lengths

*** Subject to agency Testing

801711.10

ASD FAAST LT-200 EB, single channel



Features

- 1 independant detection chambers w. individual laser smoke detector, fan, filter, sensor and monitor
- 1 channel system for connection of max. 2 pips per channel
- Bild-in and preconfigured esserbus transponder
- High sensitivity IR-LED
- 9 sensitivity levels from 0.07 % to 6.5 % obs/m
- Fault indicators provide a broad spectrum of events
- PipelQ SW for programming pipe layout, system configuration and ongoing system monitoring
- Simple LED overview with detailed fault status display
- Unique air flow pendulum graph verifies pipe network functionality
- 10 adjustable fan levels
- Advanced detection algorithms reject common nuisance conditions
- Automatically adjusts to current environmental conditions to reduce nuisance alarms, Acclimate mode
- Event Log stores up to 2.240 events
- Ultrasonic and electronic sensing for pipe and chamber air flow measurement
- USB interface
- Easy access to filter(s) and sensor(s)

Approval: VdS

The FAAST (Fire Alarm Aspiration Sensing Technology®) system is a aspirating smoke detector that draw air into a patented, high-sensitivity smoke-sensing chamber through a pipe network, it delivers highly accurate and discrete early warning fire detection. FAAST LT-200 EB includes high sensitivity laser fire detection, ultrasonic flow sensors, and internal design features to protect vulnerable components from environmental and human threats. The device is fast to install and easy to commission thanks to PipelQ pipe design and configuration software which is included as standard.

The FAAST LT-200 esserbus will be connected direct on the esserbus. All devices are member from the esserbus loop and will be easy programmed with Commissioning Software tools8000. A range of customisable settings are geared towards maximising device performance and meeting different application needs. To accommodate local installation standards or environments, flow and general fault delays can also be set.

Technical Data

Operating voltage	18.5 ... 28 V DC
Quiescent current @ 24 V DC	approx. 182 mA
Alarm current @ 24 V DC	approx. 480 mA
Operation sound level @ 24 V DC	26 dB (A) (fan level 1)
Area to be monitored	max. 1600 m ²
Max. single pipe length	100 m
Max. total branched pipe length	160 m
Max. air inlet holes	18
Ambient temperature	-10 °C ... 50 °C
Aspirated air temperature	-20 °C ... 55 °C
Air humidity	10 ... 95 % (non-condensing)
Type of protection	IP65
Housing	Plastic (ABS)
Color	black
Weight	approx. 4 kg
Specification	EN 54-20, Class A,B, C
Dimensions	W: 356 mm H: 403 mm D: 135 mm
Declaration of Performance	DOP-ASP034

 24 language foils are included

Accessories

- FL-IF-6 FAAST LT replacement integral filter
- F-INF-25 FAAST external pipe filter
- F-INF-25-RF FAAST external filter replacement pack, 4 pcs.

801722.10

ASD FAAST LT-200 EB, dual channel

Features

- 2 independant detection chambers w. individual laser smoke detector, fan, filter, sensor and monitor
- 2 channel system for connection of max. 2 pips per channel

As 801722.10, but with 2 independant channels and one laser smoke detector per channel.

Technical Data

Quiescent current @ 24 V DC	approx. 282 mA
Alarm current @ 24 V DC	approx. 690 mA
Operation sound level @ 24 V DC	26 dB (A) (fan level 1)
Declaration of Performance	DOP-ASP035

FL-IF-6

Replacement integral filter for FAAST LT-200 EB



Replacement integral filter for aspirating smoke detector FAAST LT-200 EB.

 6 x Integral filter

F-INF-25



F-INF-25 FAAST external pipe filter

External filter for use in all FAAST Systems.

Technical Data

Application temperature	-30 °C ... 70 °C
Weight	approx. 225 g
Dimensions	W: 44 mm H: 60 mm D: 294 mm

F-INF-25-RF



Replacement filter mats for F-INF-25 (1 set)

Replacement filter mats for external filter F-INF-25.

Technical Data

Dimensions	W: 29 mm H: 9,5-10 mm D: 170-175 mm
------------	-------------------------------------

 1 Set with 3 pcs.

F-BO-AFE70-2

NEW



Blow off device for pipe system

The blow-off device enables the automatic cleaning of the pipes of aspirating smoke detectors, with compressed air. Control takes place via predefined, selectable control cycles, event-controlled with contamination messages or manually via a control input. The solenoid valve controls the compressed air from a storage tank or compressor unit for short-term rinsing of the pipe system and the suction openings.

Technical Data

Operating voltage	21.6 ... 30 V DC
Quiescent current @ 24 V DC	approx. 8 mA
Ambient temperature	5 °C ... 50 °C
Aspirated air temperature	-20 °C ... 60 °C
Type of protection	IP10B
Housing	sheet steel
Color	gray white, similar to RAL 9002
Weight	approx. 3.2 kg
Dimensions	W: 204 mm H: 68 mm D: 160 mm

Features

- Compact service unit
- Preventive or event-controlled blow-out programs selectable
- Easy integration, even in inventory systems
- 6 stored, selectable programs for cyclic cleaning runs
- Control input for manual cleaning cycles
- Integrated clock module for daytime-dependent cleaning cycles
- Up to 3700l / min air flow at 7 bar air pressure



An external power supply is required for the power supply. Compressed air supply: max. permissible overpressure 0,7MPa (7,0bar) recommended minimum pressure 0,2MPa (2,0bar).

VLF-250-01



Features

- Out-of-the-Box installation and commissioning
- Ultrasonic airflow sensing
- Laser-based absolute smoke detection
- Programmable alarm thresholds
- Clean air barrier optics protect
- AutoLearn™ Flow
- AutoLearn™ Smoke
- Event log – up to 18000 events

VESDA LaserFocus VLF-250-01

Approval: G 205060

The VESDA VLF-250 detector is a very early warning smoke detector designed to protect small, business-critical environments of up to 250 m².

The VLF can be installed and commissioned out-of-the-box without the need for a special interface or software programming tools. The patent-pending Ultrasonic Flow Sensing used in the VLF provides a direct reading of the sampling pipe flow rate. The system is immune to air temperature and pressure changes and is unaffected by contamination. The VLF is the first air sampling smoke detector to use ultrasonic flow sensing.

Technical Data

Operating voltage	18 ... 30 V DC
Quiescent current @ 24 V DC	approx. 220 mA
Alarm current @ 24 V DC	approx. 295 mA
Area to be monitored	max. 250 m ²
Contact load relay	2 A @ 30 V DC NO/NC contacts
Cable termination	0.2–2.5 sq mm
Max. single pipe length	25 m
Ambient temperature	0 °C ... 38 °C
Aspirated air temperature	-20 °C ... 60 °C
Air humidity	5 ... 95 % (non-condensing)
Type of protection	IP30
Weight	approx. 2 kg
Specification	EN 54-20, Class A, B, C
Dimensions	W: 256 mm H: 183 mm D: 92 mm



Filter included in detector

Accessories

VSP-005 VESDA Filter for VLP, VLS, VLF, VLC

VLF-500

VESDA VLF-500

As VLF-250-01 but for areas up to 500 m².

Technical Data

Quiescent current @ 24 V DC	approx. 410 mA
Alarm current @ 24 V DC	approx. 490 mA

VLI-880



Features

- Suitable for Class 1 Division 2 applications
- Groups A,B,C & D
- Up to 4 inlet pipes
- Five high intensity status LEDs for greater visibility
- Robust absolute smoke detection
- Intelligent Filter (patent pending)
- Lint Trap to capture fibrous particulates
- Secondary filter
- Clean air barrier for optics protection
- AutoLearn™ Smoke and Flow
- Clean Air Zero™
- Air-path monitoring
- Five relays (Fire, Fault and 3 configurable)
- Ultrasonic flow sensing

VESDA VLI Relay only

Approval: G 212155

The VESDA VLI is an early warning aspirating smoke detection (ASD) system, designed to protect industrial applications and harsh environments of up to 2000 m².

The VLI detector combines a fail-safe intelligent filter (patent pending) with an advanced clean-air barrier for optics protection allowing the use of absolute detection and a long detection chamber life without the need for re-calibration.

The intelligent filter:

- reduces the level of pollution in the air sample before it enters the detection chamber, which dramatically extends the operational life of the detector in harsh and polluted environments.
- is fully monitored, providing consistent sensitivity over the entire operational life of the detector.

Technical Data

Operating voltage	18 ... 30 V DC
Quiescent current @ 24 V DC	approx. 415 mA
Alarm current @ 24 V DC	approx. 440 mA
Area to be monitored	max. 2000 m ²
Contact load relay	2 A @ 30 V DC NO/NC contacts
Cable termination	0.2–2.5 sq mm
Alarm sensitivity	0.005%–20% obs/m
Max. single pipe length	120 m
Max. total branched pipe length	360 m
Ambient temperature	0 °C ... 38 °C
Aspirated air temperature	-20 °C ... 60 °C
Air humidity	10 ... 95 % (non-condensing)
Type of protection	IP66
Weight	approx. 6 kg
Specification	EN 54-20, Class A, B, C
Dimensions	W: 426.5 mm H: 316.5 mm D: 180 mm



Filter included in detector

VLI-885

VESDA VLI with VesdaNet

As VLI-880 but with VesdaNet implemented.

VSP-030

NEW



VESDA intelligent filter spare part

Intelligent filter spare part for VESDA VLI.

VSP-031

NEW



VLI Secondary Filter Spare Part

Intelligent filter spare part for VESDA VLI.

VSP-032

NEW



VLI Aspirator Spare Part

Spare part aspirator for VESDA VLI.

VSP-034

NEW



VLI VESDANET CARD

Spare part card for VESDA VLI-885.

VEU-A00



Features

- Multi stage filtration and optical protection with clean air barriers
- Four alarm levels and an ultra wide sensitivity range
- Secondary monitoring and maintenance via WiFi
- USB for PC configuration, and firmware upgrade using a memory stick
- Remote monitoring with iVESDA
- Fully backward compatible with VLP and VESDAnet
- AutoLearn™ smoke and flow
- Extensive event log - 20 000 events

VESDA VEU with LEDs

Approval: G 214010

The VEU series of aspirating smoke detectors are the premium detector of the VESDA-E range. An Ultra-wide sensitivity range; 15 times greater than VESDA VLP, and provision for more sampling holes provide an increased coverage in high airflow applications by at least 40%. Considerably longer linear pipe runs and extended branched pipe network configurations cater perfectly to applications with higher ceilings providing an increased coverage by up to 80% whilst allowing convenient detector mounting for ease of service and maintenance. A range of revolutionary new features provide unsurpassed detection performance, flexibility, field programmability, connectivity and reduced total cost of ownership.

Flair Detection Technology

Flair is the revolutionary new detection chamber that forms the core of VESDA-E VEU, providing better detection, fewer nuisance alarms, higher stability, increased longevity and particle characterisation. Direct imaging of the sampled particles using a CMOS imager combined with multiple photo-diodes provides vastly more data that can be used to derive actionable information about the observed particles using analytics.

Technical Data

Operating voltage	18 ... 30 V DC
Quiescent current @ 24 V DC	max. 613 mA
Alarm current @ 24 V DC	max. 646 mA
Area to be monitored	max. 6 500 m ²
Contact load relay	2 A @ 30 V DC NO/NC contacts
Cable termination	0.2–2.5 sq mm
Alarm sensitivity	0.001%–20% obs/m
Max. single pipe length	160 m
Max. total branched pipe length	800 m
Number of holes (A/B/C)	80/80/100
Ambient temperature	0 °C ... 38 °C
Aspirated air temperature	-20 °C ... 60 °C
Air humidity	10 ... 95 % (non-condensing)
Type of protection	IP40
Weight	approx. 4,83 kg
Specification	EN 54-20, Class A, B, C
Dimensions	W: 350 mm H: 225 mm D: 135 mm



Filter included in detector

Accessories

VSP-962 VESDA Filter for VEU, VEP

VEU-A10



VESDA VEU with Display

As VEU-A00 but with a 3,5" display.

Technical Data

Quiescent current @ 24 V DC	approx. 658 mA
Alarm current @ 24 V DC	approx. 692 mA
Weight	approx. 4,9 kg

VEP-A00-P



Features

- Multi stage filtration and optical protection with clean air barriers
- Four alarm levels and an ultra wide sensitivity range
- Secondary monitoring and maintenance via WiFi
- USB for PC configuration, and firmware upgrade using a memory stick
- Remote monitoring with iVESDA
- Fully backward compatible with VLP and VESDAnet
- AutoLearn™ smoke and flow
- Extensive event log - 20 000 events

VESDA VEP 4 pipe with LEDs

Approval: G 214010

The VESDA-E VEP series of smoke detectors bring the latest and most advanced detection technology to provide very early warning and the best nuisance alarm rejection to a wide range of applications. Built on the Flair detection technology and years of application experience, VEP detectors achieve consistent performance over their lifetime via absolute calibration. In addition, the VEP delivers a range of revolutionary features that provide user value.

Flair Detection Technology

Flair is the revolutionary new detection chamber that forms the core of VESDA-E VEP, providing better detection, fewer nuisance alarms, higher stability, increased longevity and particle characterisation. Direct imaging of the sampled particles using a CMOS imager combined with multiple photo-diodes allow vastly more data that can be used to derive actionable information about the observed particles using analytics.

Technical Data

Operating voltage	18 ... 30 V DC
Quiescent current @ 24 V DC	max. 367 mA
Alarm current @ 24 V DC	max. 400 mA
Area to be monitored	max. 2 000 m ²
Contact load relay	2 A @ 30 V DC NO/NC contacts
Cable termination	0.2–2.5 sq mm
Alarm sensitivity	0.005%–20% obs/m
Max. single pipe length	110 m
Max. total branched pipe length	560 m
Number of holes (A/B/C)	40/80/100
Ambient temperature	0 °C ... 38 °C
Aspirated air temperature	-20 °C ... 60 °C
Air humidity	10 ... 95 % (non-condensing)
Type of protection	IP40
Weight	approx. 4 kg
Specification	EN 54-20, Class A, B, C
Dimensions	W: 350 mm H: 225 mm D: 135 mm



Filter included in detector

Accessories

VSP-962 VESDA Filter for VEU, VEP

VEP-A10-P



VESDA VEP 4 pipe with display

As VEP-A00-P but with a 3,5" display.

Technical Data

Quiescent current @ 24 V DC	max. 417 mA
Alarm current @ 24 V DC	max. 483 mA
Weight	approx. 4,1 kg

VEP-A00-1P

VESDA VEP 1 pipe with LEDs

As VEP-A00-P but with one pipe.

Technical Data

Max. single pipe length	100 m
Max. total branched pipe length	130 m
Number of holes (A/B/C)	30/40/45

VEA-040-A00

NEW



Features

- 40 addressable microbore tubes with individual sampling points
- Assured detection with end to end system integrity monitoring
- Interruption-free business operation with centralised testing and maintenance
- Single sampling point or single tube blockage detection at set intervals
- Automatic sampling point presence and tube breakage detection at set intervals
- Automatic sampling point cleaning at set intervals
- Three sensitivity settings for the sampling points
- Laser-based absolute smoke detection
- Coarse particle filtering and clean air barrier for optics protection
- Reliable linear pump technology
- LEDs for alarm and fault signalling
- Seven programmable relays
- Two GPIs, monitored and unmonitored
- Xtralis VSC and VSM4 PC software support
- iVESDA application for system monitoring on mobile devices
- Easy mounting with steel support bracket
- Field replaceable filter, smoke sensor module, pump and rotary valve
- Local host-mode USB port
- Easy cable termination access
- Event Log (20.000 events)

VEA-040-A10

NEW



VESDA-E VEA-40 Aspirating Smoke Detector

Approval: UL, ULC, EN 54-20, ISO 7240-20: Class A, B and C, ActivFire, CE, VdS

The VESDA-E VEA series of aspirated detectors combine VESDA reliability and early warning smoke detection with pinpoint addressability and a variety of annunciation options. They use patented air sampling points and multi-channel microbore air-sampling with three alarm sensitivity settings for the sampling points. As a multi-channel addressable system, the VEA detector is able to divide a protected space into sampling locations, enabling the localization of potential sources of fire for faster incident response. The detectors are suitable for protection of areas where pinpoint location of fire events is essential, thus providing ideal fire detection solutions for healthcare, offices, education, retail, prisons and electrical cabinets. A wide range of features provide flexibility, field programmability, enhanced connectivity and reduced total cost of ownership.

Installation, Commissioning and Maintenance

The VEA detector features a robust IP40-rated enclosure and is equipped with a powerful pump that provides up to 100 m microbore tube length. It is fully supported by the Xtralis VSC software which facilitates ease of system commissioning and maintenance. During commissioning, the normalization process establishes the flow performance parameters. Local smoke test ports are used during servicing to verify that the system is fully operational. Field replaceable filter, smoke sensor module, pump and rotary valve components result in less down time and ease of maintenance.

VESDAnet™

VESDA detectors and devices communicate on VESDAnet which provides a robust bi-directional communication network allowing continued redundant operation even during single point wiring failures. VESDAnet enables primary reporting, centralized configuration, control, maintenance and monitoring.

Ethernet and WiFi connectivity

VESDA-E detectors offer Ethernet (100BASE-T) and WiFi (802.11 b/g/n) connectivity as standard features. The detector can be added to a corporate network, allowing WiFi enabled tablet devices and laptops installed with Xtralis configuration software to connect wirelessly to the detector via the network.

Technical Data

Alarm sensitivity	0.020%–16% obs/m
Max. single pipe length	100 m
Max. total branched pipe length	4000 m
Number of holes (A/B/C)	40/40/40
Type of protection	IP40
Weight	approx. 9.9 kg
Dimensions	W: 352 mm H: 336 mm D: 135.5 mm

VESDA-E VEA-40 Detector with 3.5" Display

As VEA-040-A00 but with a Color LCD display .

The VEA-040-A10 detector features a 3.5" colour LCD display which provides a range of status information including alarm and fault conditions as well as smoke level. Screens for each type of information are available using a simple navigation system.

VER-A40-40-STX

NEW



Features

- 40 relays: each relay responds to an event that is registered on an intake line
- Enables the installation of esserbus transponders in the housing
- Easy mounted via optional bracket

VESDA-E VEA 40 relay extention StaX

The VESDA-E VEA housing (StaX) provides extra relays space for input modules of the fire alarm systems. When the VESDA-E VEA-040-A00 / A10 aspirating smoke detector detects an alarm, it scans the aspiration lines to determine which aspiration line was used to detect smoke. The associated relay of the StaX is then activated, which is assigned to the triggered suction opening.

Relay assignment: relays 1 to 40 correspond to the suction openings 1 to 40.

Technical Data

Ambient temperature	0 °C ... 39 °C
Type of protection	IP40
Weight	approx. 5.1 kg
Dimensions	B: 352.05 mm H: 340.5 mm T: 135.5 mm

VPS-250-STX

NEW



Features

- Temperature compensated charging to maximize battery life
- Designed to blend in with VESDA-E detectors
- Knockouts designed to line up with VESDA-E detectors
- External LED indication
- Relay outputs for connection to the general-purpose input for fault monitoring
- 230 VAC only

VESDA-E STX PSU 2A 24AH, black

VESDA-E Power Supply Units are uniquely designed to complement the style and appearance of VESDA-E aspirating smoke detectors (ASD) and are technically matched to provide sufficient current and battery charging capacity to meet the requirement of EN 54-4. The STX variants are VdS approved and CE marked to EN 54-4 so are particularly suitable for use in territories where these approvals are required. They may also be suitable in territories where ISO 7240-4 is required.

Technical Data

Operating voltage	0 °C ... 39 °C
Output current	IP40
Ambient temperature	approx. 5.1 kg
Air humidity	B: 352.05 mm H: 340.5 mm T: 135.5 mm
Color	approx. 5.8 kg (without batteries)
Weight	approx. 25 kg (with max. batteries)
Dimensions	W: 300 mm H: 150 mm D: 135 mm

VPS-250-STX-SLV

NEW



VESDA-E STX PSU 2A 24AH, silver

As VPS-250-STX but in silver, similar to RAL 7047.

Technical Data

Color	silver/gray, similar to RAL 7047
-------	----------------------------------

VPS-220-STX

NEW

VESDA-E STX PSU 0.5A 14AH, black

As VPS-250-STX but for 0.5 A / 14 Ah.

VPS-220-STX-SLV

NEW

VESDA-E STX PSU 0.5A 14AH, silver

As VPS-220-STX but in silver, similar to RAL 7047.

VSP-980-W

NEW



VESDA-E VEA 6 mm Standard Sampling Point white

White installation suction opening for aspirating smoke detector VEA with 6 mm capillary hose.

VSP-980-W22

NEW



VESDA-E VEA 6 mm Standard Sampling Point white

As VSP-980-W but 22 pcs pack.

VSP-981-W

NEW



VESDA-E VEA 4 mm Standard Sampling Point white

White installation suction opening for aspirating smoke detector VEA with 4 mm capillary hose.

VSP-981-W22

NEW



VESDA-E VEA 4 mm Standard Sampling Point white

As VSP-981-W but 22 pcs pack.

VSP-982-W

NEW



VESDA-E VEA 6 mm Surface Mount Sampling Point white

White installation suction opening for aspirating smoke detector VEA with 6mm capillary hose.

VSP-982-W22

NEW



VESDA-E VEA 6 mm Surface Mount Sampling Point white

As VSP-982-W but 22 pcs pack.

1

2

3

4

5

6

7

8

9

10

11

12

13

14

VSP-990-330

VEA 6 mm Microbore Tube (UL) Rated 100 m

NEW



Features

- Flame retardant
- Stress crack resistant
- Unique designation
- Distance marking at regular intervals
- Meets the requirements of international installation standards

Technical Data

Material	Polyethylene
Color	black

VSP-991

VEA 4 mm Microbore Tube (UL) Rated 150 m

NEW



As VSP-990-300 but 150 m long and 4 mm diameter.

VSP-998

VEA Blanking Plug 6mm 50 Pack

NEW



Plug for unused suction ends of 6 mm capillary tubes.

VSP-972

VEA Filter

NEW



Spare part filter for VEA aspirating smoke detector VEA.

VSP-973

VEA Pump

NEW



Spare part pump for aspirating smoke detector VEA.

VSP-1000

VEA 6 mm to 4 mm Reducer 10 Pack

NEW



The connector allows the connection/reduction between 6 mm and 4 mm capillary tubes.

VSP-1001

VEA 6 mm to 6 mm Joiner Straight 10 Pack

NEW



The connector allows the connection/extension between 6 mm and 6 mm capillary tubes.

VSP-1002

VEA 4 mm to 4 mm Joiner Right Angle 10 Pac

NEW



The connector allows the connection/extension between 4 mm and 4 mm capillary tubes.

VSP-1003

VEA 6 mm to 6 mm Joiner Right Angle 10 Pac

NEW



The connector allows the connection/extension between two 6 mm capillary tubes.

VSP-1004

VEA 4 mm to 4 mm Joiner Right Angle 10 Pac

NEW



The connector allows the connection/extension between two 4 mm capillary tubes.

VRT-300



VESDAnet™ connection box

This connection box enables external devices to be connected to the VESDAnet™. For example, a handheld programmer or a PC can be connected in conjunction with the PC interface to program the system.

VHX-0200



VESDA 300 PC interface

Used as an alternative to the programming unit. All components on the VESDAnet™ can be programmed via the interface.

Technical Data

Current consumption	70 mA
Dimensions	W: 190 mm H: 100 mm D: 40 mm



The two required connectors are included.

VSP-962



VESDA filter for VEU, VEP

Replacement air filter for VESDA VEU and VEP detectors.

1 piece

VSP-005



VESDA filter for VLP, VLS, VLF, VLC

Replacement air filter for VESDA VLP, VLS, VLF and VLC detectors.

1 piece

VSP-850-G



Air filter for VESDA aspirating systems

External filter for VESDA aspirating system for extremely polluted environments.

Technical Data

Color	gray, similar to RAL 7035
Dimensions	W: 206 mm H: 59 mm D: 33 mm

VSP-850-4



Replacement filter for VSP-850-G

Replacement filter cartridge, 1 set consisting of 4 filter cartridges.

Accessories

950101

Pipe (PVC), diameter 25 mm



Length = 25 m (each 5 m)

Technical Data

Ambient temperature -10 °C ... 60 °C

 5 pcs

761520.10

Pipe (ABS), diameter 25 mm



Length = 30 m (each 3 m)

Technical Data

Ambient temperature -40 °C ... 70 °C

 10 pcs

950119

90° bend (PVC) for 25 mm pipe



Technical Data

Ambient temperature -10 °C ... 60 °C

 10 pcs

761521.10

90° bend (ABS) for 25 mm pipe

As 950119 but ABS material.

Technical Data

Ambient temperature -40 °C ... 70 °C

950104

90° angle (PVC) for 25 mm pipe



Technical Data

Ambient temperature -10 °C ... 60 °C

 10 pcs

761522.10

90° angle (ABS) for 25 mm pipe

As 950104 but ABS material.

Technical Data

Ambient temperature -40 °C ... 70 °C

950107

45° angle (PVC) for 25 mm pipe



Technical Data

Ambient temperature -10 °C ... 60 °C

 10 Pcs.

761523.10

45° angle (ABS) for 25 mm pipe

As 950107 but ABS material.

Technical Data

Ambient temperature -40 °C ... 70 °C

950110

T-Piece (PVC) for 25 mm pipe



Technical Data

Ambient temperature -10 °C ... 60 °C

 10 pcs

761524.10

T-Piece (ABS) for 25 mm pipe

As 950110 but ABS material.

Technical Data

Ambient temperature -40 °C ... 70 °C

950116

Sleeve (PVC) for 25 mm pipe



Technical Data

Ambient temperature -10 °C ... 60 °C

 10 Pcs.

761525.10

Sleeve (ABS) for 25 mm pipe

As 950116 but ABS material.

Technical Data

Ambient temperature -40 °C ... 70 °C

950113

End cap (PVC) for 25 mm pipe



Technical Data

Ambient temperature -10 °C ... 60 °C

 10 pcs

761526.10

End cap (ABS) for 25 mm pipe

As 950113 but ABS material.

Technical Data

Ambient temperature -40 °C ... 70 °C

761549

Ceiling lead-through adapter (ABS)



Ceiling lead-through adapter (ABS) for suction hose set (Part No. 761542.10).
Almost invisible integration into false ceilings

761542.10

Suctions hose set for 25 mm pipe



For flexible installation in object surveillance or suspended ceilings.
All components are pre-mounted, but not glued; to enable cut and adaptation on-site.

Technical Data

Dimensions L: 3000 mm

1 x T piece (761524), 3 m corrugated polyester hose, (761543), 1 x ceiling lead-through adapter with threaded joint

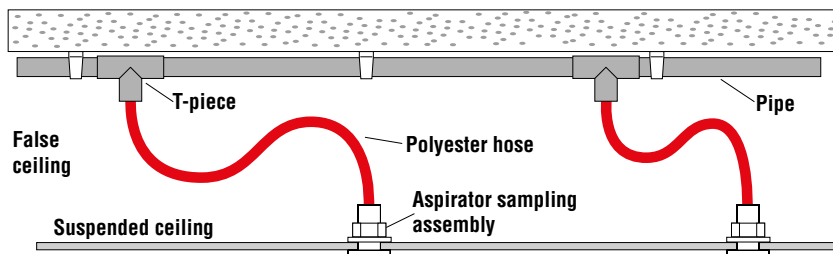

Application example: monitoring of room

F-SP

NEW



Smoke pen

Pen with wick to create a gentle hovering smoke (and for easy viewing of air flow and leaks). The wick is lit with a match or cigarette lighter (not for use near combustible gases). The smoke is safe, non-toxic, without ash or residue. The floating smoke is particularly suitable for triggering e.g. aspirating smoke detectors. Easy handling, because the wick can be lit again several times. Thus the continuous stream can be started and stopped simply by plug on the supplied protective cap on the burning lit. The total burn time is max. 30 minutes per wick.

Technical Data

Material plastic, metal
Dimensions Ø: 12 mm L: 150 mm

6 wicks for smoke production

F-SP-REFILL

NEW



Spare wicks for Smoke pen (Part No. F-SP)

With 6 spare wicks for Smoke Pen a total burn time of 3 hours (à 30 minutes burning time each wick) can be reached.

E700-SP-DCL

NEW



Banderolen zur Markierung der Ansaugpunkte

Die Banderole dient zur Markierung der Ansaugpunkte des PVC-/ABS-Rohrs.

Technische Daten

Umgebungstemperatur -10 °C ... 60 °C

Bitte beachten Sie, die Banderole dient nicht zur Verjüngung des Bohrlochs.

Rolle mit 200 Aufklebern

761535

Adhesive, 0.5 kg can with brush-in-cap



Adhesive for connecting ABS and PVC pipes.

761536

PVC detergent, 1l



Detergent for cleaning ABS and PVC pipes and fittings before gluing.

761537.10

Mounting clip for 25 mm pipe



 100 pcs

761546.10

Pipe cutter for PVC and ABS pipes



Technical Data

Material ABS

 Tool for clean, fast pipe cuts. For thin-walled pipes also, $\varnothing \leq 63 \text{ mm } \varnothing \leq 2''$.

- 1
- 2
- 3
- 4
- 5
- 6
- 7
- 8
- 9
- 10
- 11
- 12
- 13
- 14

Standard Clips

F-PC-0

NEW



Standard clip for aspirating holes 0.0mm

Technical Data

Application temperature	-30 °C ... 45 °C
Material	PC/ABS
Color	black (body)
Weight	approx. 11 g
Dimensions	W: 30.5 mm L: 55 mm

 Application where ambient temperature will exceed 45°C may lead to CLIP sealing leakage up to 5%. Please Note: Colour coding assigned accordingly to IEC 60062 standard resistor code.

 5 pcs.

F-PC-2

NEW



Standard clip for aspirating holes 2.0 mm

As F-PC-0 but with hole 2.0 and red color.

F-PC-2.5

NEW



Standard clip for aspirating holes 2.5 mm

As F-PC-0 but with hole 2.5 and red color.

F-PC-3

NEW



Standard clip for aspirating holes 3.0 mm

As F-PC-0 but with hole 3.0 and yellow color.

F-PC-3.5

NEW



Standard clip for aspirating holes 3.5 mm

As F-PC-0 but with hole 3.5 and yellow color.

F-PC-4

NEW



Standard clip for aspirating holes 4.0 mm

As F-PC-O but with hole 4.0 and yellow color.

F-PC-4.5

NEW



Standard clip for aspirating holes 4.5 mm

As F-PC-O but with hole 4.5 and yellow color.

F-PC-5

NEW



Standard clip for aspirating holes 5.0 mm

As F-PC-O but with hole 5.0 and green color.

F-PC-5.5

NEW



Standard clip for aspirating holes 5.5 mm

As F-PC-O but with hole 5.5 and green color.

F-PC-6

NEW



Standard clip for aspirating holes 6.0 mm

As F-PC-O but with hole 6.0 and blue color.

F-PC-6.5

NEW



Standard clip for aspirating holes 6.5 mm

As F-PC-O but with hole 6.5 and blue color.

1
2
3
4
5
6
7
8
9
10
11
12
13
14
15
16
17
18
19

Special Clips

F-PC-HE-2

NEW



Special clip for aspirating holes 2.0 mm

Technical Data

Application temperature	-30 °C ... 45 °C
Material	PC/ABS
Color	black (body) Main color: red
Weight	apprix. 11 g
Dimensions	W: 30.5 mm L: 55 mm

 Application where ambient temperature will exceed 45°C may lead to CLIP sealing leakage up to 5%. Please Note: Colour coding assigned accordingly to IEC 60062 standard resistor code.

 5 pcs.

F-PC-HE-2.5

NEW



Special clip for aspirating holes 2.5 mm

As F-PC-HE-2 but with hole 2.5.

F-PC-HE-3

NEW



Special clip for aspirating holes 3.0 mm

As F-PC-HE-2 but with hole 3.0 and orange color.

F-PC-HE-3.5

NEW



Special clip for aspirating holes 3.5 mm

As F-PC-HE-2 but with hole 3.5 and orange color.

F-PC-HE-4

NEW



Special clip for aspirating holes 4.0 mm

As F-PC-HE-2 but with hole 4.0 and yellow color.

F-PC-HE-4.5

NEW



Special clip for aspirating holes 4.5 mm

As F-PC-HE-2 but with hole 4.5 and yellow color.

F-PC-HE-5

NEW



Special clip for aspirating holes 5.0 mm

As F-PC-HE-2 but with hole 5.0 and green color.

F-PC-HE-5.5

NEW



Special clip for aspirating holes 5.5 mm

As F-PC-HE-2 but with hole 5.5 and green color.

F-PC-HE-6

NEW



Special clip for aspirating holes 6.0 mm

As F-PC-HE-2 but with hole 6.0 and blue color.

F-PC-HE-6.5

NEW



Special clip for aspirating holes 6.5 mm

As F-PC-HE-2 but with hole 6.5 and blue color.

Notes

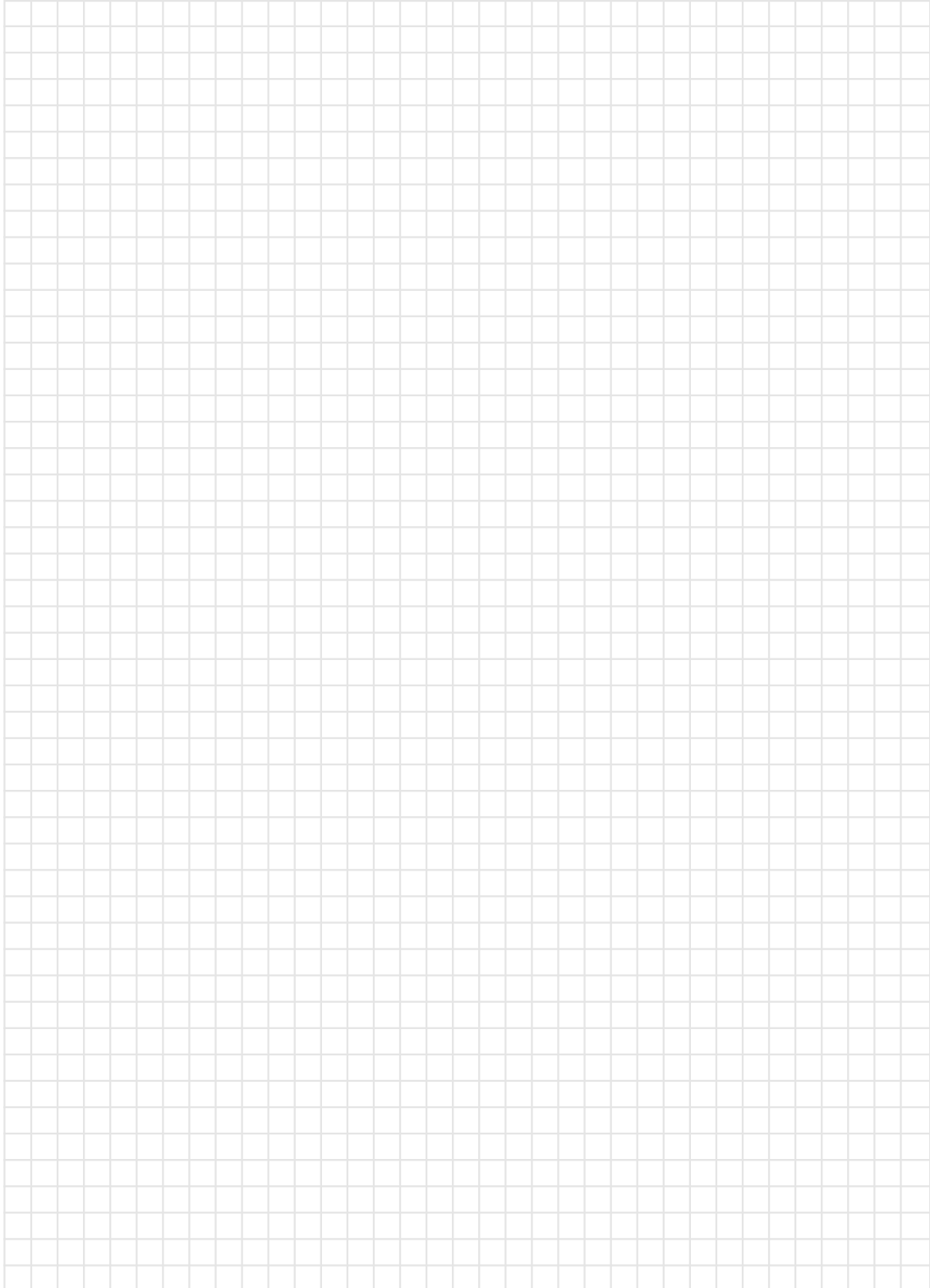



Alarm Devices

Conventional ENscape	190-196
Intelligent Addressable IQ8Alarm	197-208
Intrinsically Safe	209
Remote Indicators	210

CWSO-RR-S1

Acoustic alarm signaling device, red

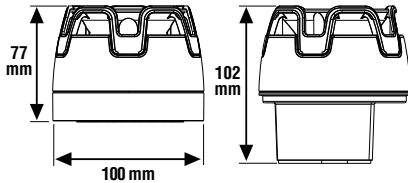

Features

- EN 54-3 compliant
- Suitable for 12 V and 24 V DC service voltage
- Synchronous sound trigger
- Volume adjustable to 2 levels at the device

Approval: G 215015

The acoustic alarm signaling device is EN 54-3 compliant, in red housing, and offers a selection of 32 signal tones including the DIN tone and other country-specific tones. All tones comply with EN 54-3. Configuration takes place via a 6-pin DIP switch. Up to two different signal tones may be activated. Signaling device with flat base, suitable for wall and ceiling mounting.

Technical Data

Operating voltage	9 ... 29 V DC
Current consumption @ 12 V DC	approx. 14.9 mA (@ DIN tone)
Current consumption @ 24 V DC	approx. 33.4 mA (@ DIN tone)
Sound level @ 12 V DC	96.2 dB(A) (@ DIN tone)
Sound level @ 24 V DC	102.1 dB(A) (@ DIN tone)
Connection terminal	0.5 ... 2.5 mm ²
Ambient temperature	-25 °C ... 70 °C
Air humidity	< 96 % (non-condensing)
Type of protection	IP21C, IP65 with CWR and accessories
Material	PC/ABS, UL94-V0
Color	red, similar to RAL 3020
Weight	approx. 190 g
Specification	EN 54-3 acoustic signaling device
Dimensions	Ø: 100 mm H: 77 mm Ø: 100 mm H: 102 mm (incl. IP base)

 Not suitable for use outdoors or in damp areas. Please use therefore the optional bases and accessories (Part No. CWR, PS188, PS189). Use of the deep IP socket reduces the dB output by an average of 4 dB. Replacement for Part No. 766225.

Accessories

- CWR Base deep IP65, red
- PS188 Base deep, O-Ring
- PS189 Base deep, seal

CWSO-WW-S1

Acoustic alarm signaling device, white



Approval: G 215015

As CWSO-RR-S1, but white color.

Technical Data

Color	white, similar to RAL 9003
-------	----------------------------

Accessories

- CWW Base deep IP 65, white

CWST-RR-S5

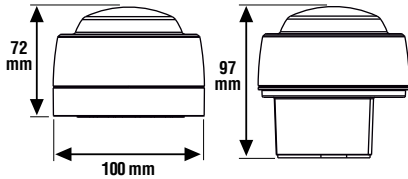

Features

- EN 54-23 compliant
- C & W category
- Synchronous flash trigger
- Up to 6.2 m room width for wall mounting
- Up to 9.4 m room diameter for ceiling mounting

Optical alarm signaling device EN 54-23 cat. W+C, red flash, red housing

Optical signaling device compliant with EN 54-23 for wall and ceiling mounting with red lamp color and flat base. The signaling device is suitable for square signal ranges W-2.4-6.2 and cylindrical signal ranges C-3-9.4 / C-6-8.2.

To help define your conventional Visual Alarm Devices (VADs) requirements in line with the EN54-23 standard, we have developed an easy to use online guide. Simply enter the room dimensions and ambient light conditions and the guide will help your device selection:

<http://www.kac.co.uk/EN54-device-chooser.htm>

Technical Data

Operating voltage	12 ... 29 V DC
Current consumption @ 24 V DC	approx. 37 mA (@ DIN tone)
Frequency of flash	approx. 0.5 Hz
Flash color	red
Connection terminal	0.5 ... 2.5 mm ²
Ambient temperature	-25 °C ... 70 °C
Air humidity	< 96 % (non-condensing)
Type of protection	IP21C, IP65 with CWR and accessories
Material	PC/ABS, UL94-V0 PC, UL94-V0 (Lens)
Category wall	W-2,4-6,2
Mounting height wall	2.4 m
Room width	6.2 m
Category ceiling	C-3-9,4 / C-6-8,2
Mounting height ceiling	3 m / 6 m
Room diameter	9,4 m / 8,2 m
Color	base red, similar to RAL 3020 cap: transparent
Weight	approx. 164 g
Specification	EN 54-23 optical signaling device
Dimensions	Ø: 100 mm H: 72 mm Ø: 100 mm H: 97 mm (incl. IP base)

 Not suitable for use outdoors or in damp areas. Please use therefore the optional bases and accessories (Part No. CWR, PS188, PS189). Replacement for Part No. 766420, 766422, 766410.

Accessories

- CWR Base deep IP65, red
- PS188 Base deep, O-Ring
- PS189 Base deep, seal

CWST-WR-S5



Optical alarm signaling device EN 54-23 cat. W+C, red flash, white housing

As CWST-RR-S5, but in a white housing.

Technical Data

Color	base white, similar to RAL 9003 cap: transparent
-------	---

Accessories

- CWW Base deep IP65, white
- PS188 Base deep, O-Ring
- PS189 Base deep, seal

CWST-WW-S5

Optical alarm signaling device, EN 54-23 cat. W+C, white flash

As CWST-WR-S5, but with a white flash.

CWSS-RR-S5

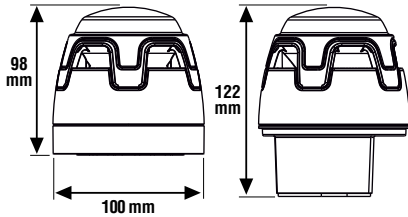

Features

- EN 54-3 and 54-23 compliant
- Synchronous sound and flash trigger
- Volume adjustable to 2 levels at the device
- C & W category
- Signal range up to 6.0 m room width for wall mounting
- Signal range up to 8.9 m room diameter for ceiling mounting

Combined acoustic/optical alarm device EN 54-23 cat. W+C, red flash, red housing

Combined acoustic and optical alarm signaling device is EN 54-3 & EN 54-23 compliant, in red housing, and offers a selection of 32 signal tones including the DIN tone and other country-specific tones. All tones comply with EN 54-3. Tone configuration takes place via a 6-pin DIP switch. Up to two different signal tones may be activated. The optical signaling device with red signal lamp is suitable in accordance with EN 54-23 for square signal ranges W-2.4-6.0 and cylindrical signal ranges C-3-8.9 / C-6-8.2. Signaling device with flat base, suitable for wall and ceiling mounting. To help define your conventional Visual Alarm Devices (VADs) requirements in line with the EN54-23 standard, we have developed an easy to use online guide. Simply enter the room dimensions and ambient light conditions and the guide will help your device selection: <http://www.kac.co.uk/EN54-device-chooser.htm>

Technical Data

Operating voltage	12 ... 29 V DC
Current consumption @ 12 V DC	approx. 63.9 mA (@ DIN tone)
Current consumption @ 24 V DC	approx. 69.9 mA (@ DIN tone)
Sound level @ 12 V DC	97 dB(A) (@ DIN tone)
Sound level @ 24 V DC	102.7 dB(A) (@ DIN tone)
Frequency of flash	approx. 0.5 Hz
Flash color	red
Connection terminal	0.5 ... 2.5 mm ²
Ambient temperature	-25 °C ... 70 °C
Air humidity	< 96 % (non-condensing)
Type of protection	IP21C, IP65 with CWW and accessories
Material	PC/ABS, UL94-V0
Category wall	W-2,4-6,0
Mounting height wall	2.4 m
Room width	6 m
Category ceiling	C-3-8,9 / C-6-8,2
Mounting height ceiling	3 m / 6 m
Room diameter	8,9 m / 8,2 m
Color	red, similar to RAL 3020 cap: transparent
Weight	approx. 248 g
Specification	EN 54-3 acoustic signaling device EN 54-23 optical signaling device
Dimensions	Ø: 100 mm H: 98 mm Ø: 100 mm H: 122 mm (incl. IP base)

 Not suitable for use outdoors or in damp areas. Please use therefore the optional bases and accessories (Part No. CWR, PS188, PS189). Use of the deep IP socket reduces the dB output by an average of 4 dB. Replacement for Part No. 766430.

Accessories

- CWR Base deep IP 65, red
- PS188 Base deep, O-Ring
- PS189 Base deep, seal

CWSS-WR-S5



Combined acoustic/optical alarm device EN 54-23 cat. W+C, red flash, white housing

As CWSS-RR-S5, but in a white housing.

Technical Data

Color	white, similar RAL 9003 cap: transparent
-------	---

Accessories

- CWW Base deep IP65, white
- PS188 Base deep, O-Ring
- PS189 Base deep, seal

CWSS-WW-S5

Combined acoustic/optical alarm device EN 54-23 cat. W+C, white flash, white housing

As CWSS-WR-S5, but in a white housing with white flash.

CWST-WA-S7

Optical alarm signaling device, amber flash

Optical alarm device for wall and ceiling mounting with amber signal flash and flat base. The device does not comply with EN 54-23.

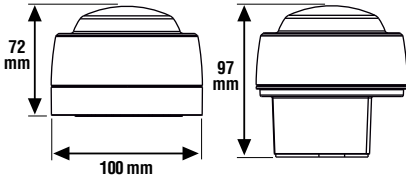

Technical Data

Operating voltage	12 ... 29 V DC
Current consumption @ 24 V DC	approx. 3 mA (@ DIN tone)
Frequency of flash	approx. 0.5 Hz
Flash color	yellow
Ambient temperature	-25 °C ... 70 °C
Air humidity	< 96 % (non-condensing)
Type of protection	IP21C, IP65 with CWW and accessories
Material	PC/ABS, UL94-V0
	PC, UL94-V0 (Lens)
Color	base: white, similar RAL 9003
	cap: amber
Weight	approx. 164 g
Dimensions	Ø: 100 mm H: 72 mm
	Ø: 100 mm H: 97 mm (incl. IP base)

 Not suitable for use outdoors or in damp areas. Please use therefore the optional bases and accessories (Part No. CWW, PS188, PS189). Replacement for Part No. 766411.

Features

- Flat design
- Synchronous flash trigger
- Low alarm power

Accessories

- CWW Base deep IP 65, white
- PS188 Base deep, O-Ring
- PS189 Base deep, seal

1

2

3

4

5

6

7

8

9

10

11

12

13

14

CWSS-WA-S7

Combined acoustic/optical alarm device, red flash, white housing

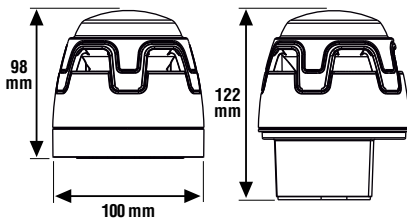

Combined acoustic and optical alarm signaling device in white housing, and offers a selection of 32 signal tones including the DIN tone and other country-specific tones. All tones comply with EN 54-3. Tone configuration takes place via a 6-pin DIP switch. The optical signaling device with amber signal lamp is suitable for applications where a sounder is required as the primary method of alarm, but a supplementary light indicator would also be of benefit.

The device does not comply with EN 54-23.

Technical Data

Operating voltage	12 ... 29 V DC
Current consumption @ 24 V DC	approx. 22 mA (@ DIN tone 7)
Sound level @ 1 m	107 dB(A) (@ DIN tone 23)
Flash color	red
Connection terminal	0.5 ... 2.5 mm ²
Ambient temperature	-25 °C ... 70 °C
Air humidity	< 96 % (non-condensing)
Type of protection	IP21C, IP65 with CWW and accessories
Material	PC/ABS, UL94-V0
Color	base: white, similar RAL 9003 cap: amber
Weight	approx. 242 g
Specification	EN 54-3 acoustic signaling device
Dimensions	Ø: 100 mm H: 98 mm Ø: 100 mm H: 122 mm (incl. IP base)

Features

- Approved to EN54-3 for sound
- 32 approved tones including bell tone
- LED technology & advanced optics provides light indication at very low current draw
- Synchronisation of flash and sound.
- Operates on 12V and 24V systems



Not suitable for use outdoors or in damp areas. Please use therefore the optional bases and accessories (Part No. CWW, PS188, PS189).

Accessories

- CWW Base deep IP 65, white
- PS188 Base deep, O-Ring
- PS189 Base deep, seal

CWSS-RR-S3

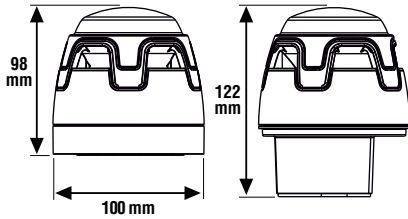

Features

- EN 54-3 compliant
- Cat. O under EN 54-23
- Synchronous sound and flash trigger
- Volume adjustable to 2 levels at the device
- Suitable for wall and ceiling mounting

Combined acoustic/optical alarm device EN 54-3, open class, red flash, red housing

Combined acoustic alarm signaling device is EN 54-3 compliant with additional optical display, in red housing, and offers a selection of 32 signal tones including the DIN tone and other country-specific tones. All tones comply with EN 54-3. Tone configuration takes place via a 6-pin DIP switch. Up to two different signal tones may be activated. Signaling device with flat base, suitable for wall and ceiling mounting.

The integrated optical display with red signal flash is only authorized under EN 54-23 in open category O for 24–29 V DC operating voltage. Below 24 V DC, the device is classified as an acoustic signaling device with additional display. To help define your conventional Visual Alarm Devices (VADs) requirements in line with the EN54-23 standard, we have developed an easy to use online guide. Simply enter the room dimensions and ambient light conditions and the guide will help your device selection:

<http://www.kac.co.uk/EN54-device-chooser.htm>.

Technical Data

Operating voltage	12 ... 29 V DC
Current consumption @ 12 V DC	approx. 15.5 mA (@ DIN tone)
Current consumption @ 24 V DC	approx. 35.4 mA (@ DIN tone)
Sound level @ 12 V DC	96.5 dB(A) (@ DIN tone)
Sound level @ 24 V DC	102.5 dB(A) (@ DIN tone)
Frequency of flash	approx. 0.5 Hz
Flash color	red
Connection terminal	0.5 ... 2.5 mm ²
Ambient temperature	-25 °C ... 70 °C
Air humidity	< 96 % (non-condensing)
Type of protection	IP 21C, IP 65 with CWR and accessories
Material	PC/ABS, UL94-V0
Color	red, similar RAL 3020 cap: transparent
Weight	approx. 236 g
Specification	EN 54-3 acoustic signaling device EN 54-23 optical signaling device, (Cat O, 24 ... 29 V DC)
Dimensions	Ø: 100 mm H: 98 mm Ø: 100 mm H: 122 mm (incl. IP base)

 Not suitable for use outdoors or in damp areas. Please use therefore the optional bases and accessories (Part No. CWR, PS188, PS189). Use of the deep IP socket reduces the dB output by an average of 4 dB. Replacement for Part No. 766240.

Accessories

- CWR Base deep IP 65, red
- PS188 Base deep, O-Ring
- PS189 Base deep, seal

CWSS-WR-S3



Combined acoustic/optical alarm device EN 54-3, open class, red flash, white housing

As CWSS-RR-S3, but in a white housing.

CWR



Base deep IP 65, red

Base, red, for ENscape signaling device with IP 65 protection rating and sm cable entry.

Technical Data

Type of protection	IP65 (with accessories)
Material	PC/ABS, UL94-V0
Color	red, similar to RAL 3020
Weight	approx. 47 g
Dimensions	Ø: 100 mm H: 53 mm

 5 pcs

Accessories

- PS 188 Base deep, O-Ring
- PS 189 Base deep, seal
- SC076 Grounding bridge for deep base

CWW



Base deep IP 65, white

As CWR, but white color.

Technical Data

Color	white, similar to RAL 9003
-------	----------------------------

 5 pcs

PS188



O-Ring for deep base

Replacement O-ring for use with deep CWR or CWW base.

Technical Data

Material	MBR 70
Color	black

 5 pcs

PS189



Seal for deep base

Seal for use with deep CWR or CWW base for IP 65 protection rating.

Technical Data

Material	closed-cell neoprene
Color	black

 5 pcs

SC076

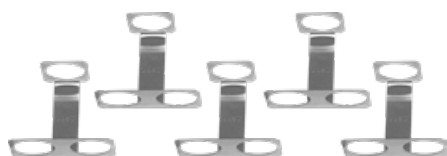

Ground jumper for deep base

Grounding strap for use with deep CWR or CWW base.

Technical Data

Material	Stainless steel
----------	-----------------

 5 pcs

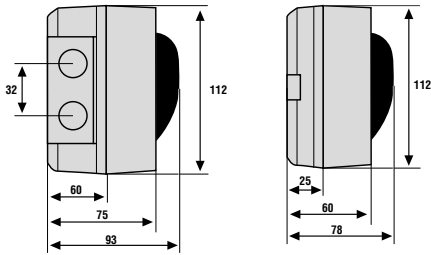

Features

- Completely bus supplied alarm device
- Powered loop compatible
- Low power consumption
- Up to 64 alarm devices for each powered loop
- Each alarm device has built-in isolator
- Synchronous trigger

Acoustic alarm signaling:

- EN 54-3 compliant
- High acoustic pressure
- Volume programmable in 8 steps via tools 8000
- 20 different signaling tones, including DIN tone
- Multilingual speech alarm in 5 different languages
- Alarm signaling, evacuation, and test alarm can each be programmed in different languages
- Speech alarm, 5 pre-programmed alarm texts and other country-typical alarm signals
- Tones can be used for other purposes in addition to warning of fire, making the device ideal for use in schools etc.
- Soft start option, ideal for hospitals and nursing homes
- Special variant with individual combination of up to 5 languages available
- Special variant with individual texts and/or sounds available

Optical alarm signaling:

- EN 54-23 compliant
- W category
- Signal range up to 8.0 m room width for wall mounting
- square signal range/ room size configurable via tool8000

IQ8Alarm Plus enables IQ8Quad detector application with integrated alarm signaling and other advantages. No matter whether multilingual speech alarm, flexible signal combination or userfriendly programming interfaces, all these features are also available when using IQ8Alarm Plus. With various country-specific alarm tones (e.g. DIN tone or the Dutch slow-woop tone), and the completely loop powered optical alarm signaling acc EN 54-23 (VAD) as well as with 5 different voice messages in up to 5 languages, the IQ8Alarm Plus with its outstanding features is one of the safest and most economical ways to alert.

The device is directly installed at and connected to the esserbus-PLus (powered loop) system, making expensive external voltage supplies and connection modules dispensable.

Advantages with IQ8Alarm Plus at a glance:

- Simple programming enabled by a standardized programming interface for all IQ8 Systems (IQ8Quad + IQ8Alarm Plus) addressable alarm signaling devices
- Loop is powered without additional power supply
- Time-tested, unobtrusive design
- Signaling device (sounder) in compliance with EN 54-3 with 20 different signaling tones including DIN tone in compliance with DIN 33404-3
- Alarm device in compliance with EN 54-3 with 5 pre-programmed alarm messages in 5 different languages
- Visual Alarm Device (VAD) in compliance with EN 54-23, with configurable room sizes

On the following pages, you will find more detailed information about IQ8Alarm Plus features.

Alarm tone / speech message programming

For IQ8Alarm Plus with speech message and/or alarm tone function with up to five language options, up to 4 signals can be programmed. Two signals are reserved for alarm signaling and evacuation in the case of fire. Two further signals can be programmed for other events. Each signal can consist of up to four signal components, enabling one signal to be programmed as a DIN tone combined with subsequent speech messages in three different languages. Alarm tones can be chosen from a table with various tone types. For application in schools, a break signal to signify the breaks between class can be activated. When the basic setting is selected, signals / signal components can be continuously repeated until the signaling function is interrupted by the control panel. They can also be programmed with a repetition rate of one to three times. Thus, the break signal in schools can be deliberately set to only one repetition. In the same way, the total signal can be set to continuous repetition, with the DIN tone being played only once while subsequent speech messages are played up to three times.

Calculation of the maximum number of alarm devices on esserbus-PLus powered loop:

The maximum number of bus-enabled alarm devices on esserbus-PLus powered loop depends on the type of alarm device (and selected settings), load factor, loop length and cross section. For this purpose, the individual load factors of the individual alarm devices must be added. The load factor defines the current consumption of the alarm device on the ring bus in the event of an alarm. The maximum permissible total load factor of a single loop is 96 (consider FACP information). Altogether up to 127 bus devices per loop can still be connected. A calculation tool is available on our website to determine the load factor values. Please note our examples and tables in the appendix. All information required for programming IQ8Alarm Plus devices can be obtained when attending our programming training courses.



Please consider:





- Admissible maximum loop length
- Admissible maximum number of single alarm device types
- Maximum number of 127 bus devices for each loop

Systems requirements:















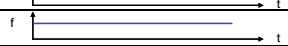

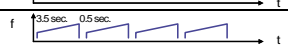
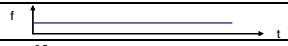

- FACP IQ8Control from version V3.04
- FACP FlexES Control
- FACP Compact
- esserbus-PLus/powerd loop functionality
- Programming software tools 8000 from version V1.20
- To change the factory settings for EN 54-23 square signal ranges programming software tools 8000 from version V1.24 is required.

Attention - an operation with the FACP'S 8000 C/M is not possible!!!

Old P/N EN 54-3	New P/N EN 54-3 & 54-23	Name / Function	 F Flash	 So Sound	 Sp Speech	Housing color	Flash color	Load Factor			max. number on one loop
								LF	LF	LF	
								Flash	Sound	Total	
807212	---										
807213	807214WW	IQ8Alarm Plus /F (launched)	x			white	white	3,0-7,9	--	3,0-7,9	32
807214	807214RR	IQ8Alarm Plus /F (launched)	x			red	red	3,0-7,9	--	3,0-7,9	32
807205	807205W	IQ8Alarm Plus /So		x		white	--	--	1,5 / 3,0	1,5 / 3,0	64
807206	807205R	IQ8Alarm Plus /So		x		red	--	--	1,5 / 3,0	1,5 / 3,0	64
807224	807224RR	IQ8Alarm Plus /FSo	x	x		red	red	3,0-7,9	1,5 / 3,0	4,5-10,9	21
---	807224RW	IQ8Alarm Plus /FSo	x	x		red	white	3,0-7,9	1,5 / 3,0	4,5-10,9	21
807322	807322W	IQ8Alarm Plus /Sp		x	x	white	--	--	4	4	24
807322.SV98	807322W.SV98	IQ8Alarm Plus /Sp		x	x	white	--	--	4	4	24
807322.SV99	807322W.SV99	IQ8Alarm Plus /Sp		x	x	white	--	--	4	4	24
807332	807322R	IQ8Alarm Plus /Sp		x	x	red	--	--	4	4	24
807332.SV98	807322R.SV98	IQ8Alarm Plus /Sp		x	x	red	--	--	4	4	24
807332.SV99	807322R.SV99	IQ8Alarm Plus /Sp		x	x	red	--	--	4	4	24
807372	807372RR	IQ8Alarm Plus /FSp	x	x	x	red	red	3,0-7,9	4	7,0-11,9	13
807372.SV98	807372RR.SV98	IQ8Alarm Plus /FSp	x	x	x	red	red	3,0-7,9	4	7,0-11,9	13
807372.SV99	807372RR.SV99	IQ8Alarm Plus /FSp	x	x	x	red	red	3,0-7,9	4	7,0-11,9	13
---	807372RW	IQ8Alarm Plus /FSp	x	x	x	red	white	3,0-7,9	4	7,0-11,9	13
---	807372RW.SV98	IQ8Alarm Plus /FSp	x	x	x	red	white	3,0-7,9	4	7,0-11,9	13
---	807372RW.SV99	IQ8Alarm Plus /FSp	x	x	x	red	white	3,0-7,9	4	7,0-11,9	13
807372.BR	807372RR.BR	IQ8Alarm Plus /FSp	x	x	x	red	red	3,0-7,9	4	7,0-11,9	13
807372.N0	807372RR.N0	IQ8Alarm Plus /FSp	x	x	x	red	red	3,0-7,9	4	7,0-11,9	13
807372.MAR	---										
806201	806201	IQ8Alarm IP base, white				white					
806202	806202	IQ8Alarm IP base, red				red					

Country code acc. to ISO 3166 -Alpha-2	Language code acc. to ISO 639-1	Evacuation 1	Evacuation 2	Alarm	Test-message	All-Clear
 Germany (DE)	de	Dies ist ein Feueralarm. Bitte verlassen Sie das Gebäude umgehend über die nächsten Fluchtwege. Die Feuerwehr ist alarmiert.	Achtung, Achtung! Dies ist eine Gefahremeldung. Bitte verlassen Sie das Gebäude über die nächsten Ausgänge.	Achtung, im Gebäude ist eine Gefahrensituation gemeldet worden. Bitte bleiben Sie ruhig, und warten Sie auf weitere Anweisungen.	Dies ist eine Testdurchsage.	Die Gefahrensituation ist jetzt behoben. Wir entschuldigen uns für jegliche Unannehmlichkeiten.
 Great Britain (GB)	en	This is a fire alarm. Please leave the building immediately by the nearest available exit.	Attention please. This is an emergency. Please leave the building by the nearest available exit.	An incident has been reported in the building. Please await further instructions.	This is a test message. No action is required.	The emergency is now cancelled. We apologize for any inconvenience.
 France (FR)	fr	Ceci est une alarme incendie, veuillez évacuer immédiatement les locaux par la sortie la plus proche.	Votre attention s'il vous plaît, ceci est une alarme. Veuillez évacuer les locaux par la sortie la plus proche.	Un incident est signalé dans le bâtiment. Merci de garder votre calme et attendez les prochaines instructions.	Ceci est un test.	L'alarme est à présent annulée. Veuillez nous excuser pour le désagrément.
 Spain (ES)	es	Esto es una alarma de incendio. Abandonen por favor el edificio inmediatamente por la salida de evacuación más cercana.	Atención. Esto es una emergencia. Por favor abandonen el edificio por la salida de evacuación más cercana.	Atención, se ha reportado un incidente en el edificio. Aguarden por favor otras instrucciones.	Esto es un mensaje de prueba. No se requiere ninguna acción.	La emergencia ha sido cancelada. Pedimos disculpas por las molestias causadas.
 Italy (IT)	it	Attenzione. Allarme incendio. Abbandonare l'edificio tramite l'uscita di emergenza più vicina.	Attenzione. Allarme in corso. Vi preghiamo di recarvi presso l'uscita di emergenza più vicina.	Attenzione. E' stato rilevato un allarme. Ulteriori disposizioni vi verranno comunicate appena possibile.	Attenzione. E' in corso una prova di allarme. Non è richiesta alcuna azione.	Attenzione. Cessato allarme. La situazione di normalità è stata ripristinata.

Standard speech messages of IQ8Quad detectors and IQ8Alarm - for other languages also refer to the appendix!

No.	Description	Frequency	Pulse rate
1	School bell	complex	complex
2	FP 1063.1 Telecoms BS 5839 Pt1	Alternating 800 / 970 Hz at 2 Hz	
3	BS 5839 Pt1	Alternating 800 / 970 Hz at 1 Hz	
4	BS 5839 Pt1	Intermittent 970 Hz at 1 Hz 0.5 sec.	
5	BS 5839 Pt1	Intermittent 2850 Hz at 1 Hz 0.5 sec.	
6	BS 5839 Pt1	Intermittent 970 Hz 1/4 sec. ON - 1 sec. OFF	
7	BS 5839 Pt1	Continuous 970 Hz	
8	BS 5839 Pt1	Sweep tone 800 Hz tp 970 Hz at 7 Hz	
9	BS 5839 Pt1	Sweep tone 800 Hz to 970 Hz at 1 Hz	
10	DIN Tone DIN 33404 Part 3	1200 - 500 Hz at 1 Hz	
11	French fire sound	554 Hz / 100 ms + 440 Hz / 400 ms + 10 %	
12	NL - Slow Whoop	500 Hz - 1200 Hz at 3.5 sec. break of 0.5 sec.	
13	US - Horn	Continuous 485 Hz	
14	US - Horn with Temporal Pattern	Intermittent 485 Hz (0,5 sec. ON; 0,5 sec. OFF; 3 times; 1,5 sec. OFF; Repeat)	
15	US - March Time	Alternating 485 Hz (0,25 sec. ON; 0,25 sec. OFF; Repeat)	
16	US - Slow Whoop	Sweep tone 500 Hz to 1200 Hz (4,0 sec. ON; 0,5 sec. OFF; Repeat)	
17	US - Siren	Sweep tone 600 Hz to 1200 Hz (1,0 sec. ON, Repeat)	
18	US - Hi/Lo	Alternating 100 Hz / 800 Hz (0,25 sec. ON; Alternate; 0,25 sec. ON; Alternate; Repeat)	
19	US - NFPA Whoop	Sweep tone 422 Hz to 775 Hz (upwards sweep 0,85 sec.; 3 times; 1 sec. OFF; Repeat)	
20	IMO GA-Signal	Intermittent 800 Hz (1,0 sec. ON; 1,0 sec. OFF; 7 times; 2,0 sec. ON; 2,0 sec. OFF; Repeat)	

IQ8Quad detectors and IQ8Alarm tone table

IQ8Alarm Plus - Sounder Devices

807205W

NEW



Features

- Completely bus supplied alarm device
- Powered loop compatible
- Low power consumption
- Up to 64 alarm devices for each powered loop
- Each alarm device has built-in isolator
- Synchronous trigger

Acoustic alarm properties:

- EN 54-3 compliant
- High acoustic pressure
- Volume programmable in 8 steps via tools 8000
- 20 different signaling tones, including DIN tone

IQ8Alarm Plus/So sounder, white

Approval: VdS

Addressable, completely bus supplied and short circuit / open circuit resilient fire alarm sounder in compliance with EN 54-3 with integrated signaling tones for acoustic alarm signaling. With up to 20 different programmable signaling tones including DIN tone in accordance with DIN 33404 Part 3. The volume can be set to 8 different levels. The load factor can be set to 2 different levels. Signaling device with flat base, suitable for wall and ceiling mounting. Optionally, IP base Part No. 806201 with side cable entry and weatherproof protection can be installed.

Technical Data

Operating voltage	14 ... 42 V DC (via powered loop)
Quiescent current @ 19 V DC	approx. 55 µA
Quiescent current @ FACP battery	approx. 300 µA @ 42 V
Load factor acoustic	1,5 *1 / 3
Sound level	91 *1 / 97 dB (A) +/- 2 dB @ 1 m / @ 90° angle / @ DIN Tone EN 54-3 Sounder
Ambient temperature	-10 °C ... 55 °C
Storage temperature	-25 °C ... 55 °C
Air humidity	< 95 % (non-condensing)
Type of protection	IP 56 with IP base 806201 *3
Housing	Polycarbonate plastic
Color	white, similar to RAL 9010
Weight	approx. 300 g (with base)
	EN 54-3 acoustic speech signaling device (Q2/2011)
Dimensions	Ø: 112 mm D: 78 mm
	Ø: 112 mm D: 93 mm (with IP base)
Declaration of Performance	DoP-21430171215

- When using the flat IP base the db output reduces by an average of 3 dB.
- *1 Factory setting, configuration with service- and programming software tools 8000
- *2 IP 21C acc. EN 54-3 / -23
- *3 Do not use the base for acoustic alarm applications in compliance with EN 54-3 Replacement for Part No. 807205

Accessories

806201 IP base, white

807205R

NEW



IQ8Alarm Plus/So sounder, red

Approval: VdS

Same as 807205W, but red.

Technical Data

Color	red, similar to RAL 3020
-------	--------------------------

Accessories

806202 IP base, red

IQ8Alarm Plus - Sounder Devices with Speech

807322W

IQ8Alarm Plus/SpSo sounder with speech, white

NEW



Approval: VdS

Same as 807205W, but with additional speech alarm function.

Accessories

806201 IP base, white

807322W.SV98

IQ8Alarm Plus/SpSo sounder with speech, white, composed version

NEW



Approval: VdS

Same as 807322W, but with an individual combination of up to 5 languages, see special order form in the appendix.

 When ordering, please note the "Ordering information for IQ8Quad and IQ8Alarm Plus" and fill in "Order form for individual combination of languages" printed in the appendix. Cancellations or returns are not possible.

 Programmed with an individual selection of up to 5 national languages

807322W.SV99

IQ8Alarm Plus/SpSo sounder with speech, white, composed version

NEW



Approval: VdS

Same as 807322W, but with an individual combination of up to 5 languages, see special order form in the appendix. The maximum recording time per device is 169 seconds.

 When ordering, please note the "Ordering information for IQ8Quad and IQ8Alarm Plus" and fill in "Order form for individual combination of languages" printed in the appendix. Cancellations or returns are not possible.

 Programmed with an individual selection of up to 5 national languages

807322R

NEW



IQ8Alarm Plus/Sp sounder with speech, red

Approval: VdS

Same as 807322W, but red.

Technical Data

Color red, similar to RAL 3020



Programmed with an individual selection of up to 5 national languages

Accessories

806202 IP base, red

807332R.SV98

NEW



IQ8Alarm Plus/Sp sounder with speech, red, composed version

Approval: VdS

Same as 807322W.SV98, but with an individual combination of up to 5 languages, see special order form in the appendix.



When ordering, please note the "Ordering information for IQ8Quad and IQ8Alarm" and fill in "Order form for individual combination of languages" printed in the appendix. Cancellations or returns are not possible.

Accessories

806202 IP base, red

807332R.SV99

NEW



IQ8Alarm Plus/Sp sounder with speech, red, customized version

Approval: VdS

Same as 807322W.SV99, but with individual text and/or sounds. The maximum recording time per device is 169 seconds.



When ordering, please note the "Ordering information for IQ8Quad and IQ8Alarm" and fill in "Order form for individual combination of languages" printed in the appendix. Costs for the recording of customer specific texts and/or tones can be obtained on request. Cancellations or returns are not possible.

Accessories

806202 IP base, red

IQ8Alarm Plus - VAD

807214WW

IQ8Alarm Plus/F visual alarm device, white/white



Features

- Completely bus supplied alarm device
- Powered loop compatible
- Low power consumption
- Up to 32 alarm devices for each powered loop
- Each alarm device has built-in isolator
- EN 54-23 compliant
- W category
- Signal range up to 8.0 m room width for wall mounting
- Room size configurable via tools 8000

Approval: VdS

Addressable, completely bus supplied and short circuit / open circuit resilient Visual Alarm Device (VAD) compliant with EN 54-23, with white light flash, for optical alarm signaling. The optical signaling device is suitable for square signal ranges W-2.4-5.0 to W-3.6-8. The optical signal range is adjustable in 6 sizes via tools 8000. Signaling device with flat base, suitable for wall mounting. Optionally, IP base Part No. 806201 with side cable entry and weather-proof protection can be installed.

Technical Data

Operating voltage	14 ... 42 V DC (via powered loop)
Quiescent current @ 19 V DC	approx. 55 µA
Luminous intensity	approx. 6,6 cd eff. *1 / max. 17 cd eff. @ W-3,6-8
Frequency of flash	0.5 Hz *1 / 1 Hz
Flash color	white
Ambient temperature	-20 °C ... 70 °C
Air humidity	< 95 % (non-condensing)
Type of protection	IP 56 with IP base 806201 *3
Signal Range	W-2,4-5 / 60 m ³ *1 ... W-3,6-8 / 230 m ³
Housing	Polycarbonate plastic
Color	white, similar to RAL 9010
Weight	Calotte: translucent / partially frosted approx. 300 g (with base)
Dimensions	Ø: 112 mm H: 78 mm Ø: 112 mm H: 93 mm (with IP base)
Declaration of Performance	DoP-21429150413



*1 Factory setting, configuration with service- and programming software tools 8000.

*2 IP 21C acc. EN 54-3 / -23

*3 Do not use the base for acoustic alarm applications in compliance with EN 54-3 Replacement for Part No. 807214.

- To change the factory settings for EN 54-23 square signal ranges programming software tools 8000 from version V1.24 is required.

Accessories

806201 IP base, white

807214RR

IQ8Alarm Plus/F visual alarm device, red/red



Approval: VdS

Same as 807214WW, but with red housing and red flash.

Accessories

806202 IP base, red

IQ8Alarm Plus - VAD with Sound

807224R

NEW

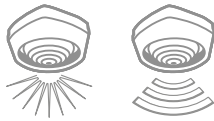

Features

- Completely bus supplied alarm device
- Powered loop compatible
- Low power consumption
- Up to 21 alarm devices for each powered loop
- Each alarm device has built-in isolator
- Synchronous trigger

Acoustic alarm signaling

- EN 54-3 compliant
- High acoustic pressure
- Volume programmable in 8 steps via tools 8000
- 20 different signaling tones, including DIN tone

Optical alarm signaling:

- EN 54-23 compliant
- W category
- Signal range up to 8.0 m room width for wall mounting
- Room size configurable via tools 8000

IQ8Alarm Plus/FSo visual alarm device with sound, red/red

Approval: VdS

Addressable, completely bus supplied and short circuit / open circuit resilient combined fire alarm sounder and Visual Alarm Device (VAD) in compliance with EN 54-3 & EN 54-23 with integrated signaling tones and red light flash for acoustic and optical alarm signaling. With up to 20 different programmable signaling tones including DIN tone in accordance with DIN 33404 Part 3.

The volume can be set to 8 different levels.

The optical signaling device is suitable for square signal ranges W-2.4-5 to W-3.6-8.

The optical signal range is adjustable in 6 sizes via tools 8000.

Signaling device with flat base, suitable for wall mounting.

Optionally, IP base Part No. 806202 with side cable entry and weatherproof protection can be installed.

Technical Data

Operating voltage	14 ... 42 V DC (via powered loop)
Quiescent current @ 19 V DC	approx. 55 µA
Quiescent current @ FACP battery	approx. 300 µA @ 42 V
Signal Range	W-2,4-5 / 60 m³ *1 (factory) ... W-3,6-8 / 230 m³
Sound level	91 *1 / 97 dB (A) +/- 2 dB @ 1 m / @ 90° angle / @ DIN Tone, EN 54-3 sounder
Frequency of flash	0.5 Hz *1 / 1 Hz
Flash color	red
Luminous intensity	approx. 6.6 cd eff. *1 / max. 17 cd eff. @ W-3,6-8
Ambient temperature	-10 °C ... 55 °C
Storage temperature	-25 °C ... 75 °C
Air humidity	< 95 % (non-condensing)
Type of protection	IP 56 with IP base 806202 *3
Color	red, similar to RAL 3020
Calotte:	translucent / partially frosted
Housing	Polycarbonate plastic
Weight	approx. 300 g (with base)
Dimensions	Ø: 112 mm D: 78 mm Ø: 112 mm D: 93 mm (with IP 65 base)
Declaration of Performance	DoP-21431171215

- When using the flat IP base the db output reduces by an average of 3 dB.
- *1 Factory setting, configuration with service- and programming software tools 8000.
- *2 IP 21C acc. EN 54-3 / -23
- *3 Do not use the base for acoustic alarm applications in compliance with EN 54-3 Replacement for Part No. 807224.
- To change the factory settings for EN 54-23 square signal ranges programming software tools 8000 from version V1.24 is required.

Accessories

806202 IP base, red

807224RW

NEW

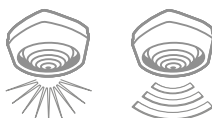

IQ8Alarm Plus/FSo visual alarm device with sound, red/white

Approval: VdS

Same as in 807224R, but with white flash.

Technical Data

Flash color	white
Color	red, similar to RAL 3020

Accessories

806202 IP base, red

IQ8Alarm Plus - VAD with Sound

807372RR

NEW



Features

- Completely bus supplied alarm device
- Powered loop compatible
- Low power consumption
- Up to 13 alarm devices for each powered loop
- Each alarm device has built-in isolator
- Synchronous trigger

Acoustic alarm signaling

- EN 54-3 compliant
- High acoustic pressure
- Volume programmable in 8 steps via tools 8000
- 20 different signaling tones, including DIN tone
- Multilingual speech alarm in 5 different languages

Alarm signaling, evacuation, and test alarm can each be programmed in different languages
 Speech alarm, 5 pre-programmed alarm texts and other country-typical alarm signals

Optical alarm signaling:

- EN 54-23 compliant
- W category
- Signal range up to 8.0 m room width for wall mounting
- Room size configurable via tools 8000

IQ8Alarm Plus/FSpSo visual alarm device with sound/speech, red/red

Approval: VdS

Addressable, completely bus supplied and short circuit / open circuit resilient combined voice sounder and Visual Alarm Device (VAD) in compliance with EN 54-3 & EN 54-23 with integrated voice messages, signaling tones and red light flash for acoustic and optical alarm signaling. With up to 20 different programmable signaling tones including DIN tone in accordance with DIN 33404 Part 3.

Speech alarm with 5 pre-programmed alarm messages in 5 different languages. The volume can be set to 8 different levels.

Selection or combination of speech messages and signaling tones as well the volume control are carried out via the tools 8000 programming software.

The optical signaling device is suitable for square signal ranges W-2.4-5 to W-3.6-8.

The optical signal range is adjustable in 6 sizes via tools 8000.

Signaling device with flat base, suitable for wall mounting.

Optionally, IP base Part No. 806202 with side cable entry and weatherproof protection can be installed.

Technical Data

Operating voltage	14 ... 42 V DC (via powered loop)
Quiescent current @ 19 V DC	approx. 55 µA
Quiescent current @ FACP battery	approx. 300 µA @ 42 V
Signal Range	W-2,4-5 / 60 m³ *1 (factory) ... W-3,6-8 / 230 m³
Sound level	90 db(A) +/- 2 dB@1 m/@ 90°/@ DIN tone, for speech & tone
	97 db(A) +/- 2 dB @ 1 m / @ 90° / @ DIN tone, only tone
	EN 54-3 Sounder, EN 54-3 Voice Sounder
Frequency of flash	0.5 Hz *1 / 1 Hz
Flash color	red
Luminous intensity	approx. 6,6 cd eff. *1 / max. 17 cd eff. @ W-3,6-8
Ambient temperature	-10 °C ... 55 °C
Storage temperature	-25 °C ... 75 °C
Loadfactor total	7 *1 ... 11.9
Load factor optic	3 *1 ... 7.9
Air humidity	< 95 % (non-condensing)
Type of protection	IP 56 with IP base 806202 *3
Color	red, similar to RAL 3020
	Calotte: translucent
Housing	Polycarbonate plastic
Weight	approx. 300 g (with base)
Dimensions	Ø: 112 mm D: 78 mm
	Ø: 112 mm D: 93 mm (with IP 65 base)
Declaration of Performance	DoP-21431171215



When using the flat IP base the db output reduces by an average of 3 dB.

*1 Factory setting, configuration with service- and programming software tools 8000.

*2 IP 21C acc. EN 54-3 / -23

*3 Do not use the base for acoustic alarm applications in compliance with EN 54-3 Replacement for Part No. 807372.

- To change the factory settings for EN 54-23 square signal ranges programming software tools 8000 from version V1.24 is required.

Accessories

806202 IP base, red

807372RR.SV98

NEW



IQ8Alarm Plus/FSpSo VAD with sound/speech, red/red, composed version

Approval: VdS

Same as 807372RR, but with an individual combination of up to 5 languages, see special order form in the appendix.

 When ordering, please note the "Ordering information for IQ8Quad and IQ8Alarm Plus" and fill in "Order form for individual combination of languages" printed in the appendix. Cancellations or returns are not possible.

 Programmed with 5 languages in accordance with composed combination.

Accessories

806202 IP base, red

807372RR.SV99

NEW



IQ8Alarm Plus/FSpSo VAD with sound/speech, red/red, customized version

Approval: VdS

Same as 807372RR, but with individual texts and/or sounds. The maximum recording time per device is 169 seconds.

 When ordering, please note the "Ordering information for IQ8Quad and IQ8Alarm Plus" and fill in "Order form for individual combination of languages" printed in the appendix. Costs for the recording of customer specific texts and/or tones can be obtained on request. Cancellations or returns are not possible.

 Programmed according to customer specifications.

Accessories

806202 IP base, red

807372RW

NEW



IQ8Alarm Plus/FSpSo visual alarm device with sound/speech, red/white

Approval: VdS

Same as in 807372RR, but with white flash.

Technical Data

Flash color	white
Color	red, similar to RAL 3020

Accessories

806202 IP base, red

807372RW.SV98

NEW



IQ8Alarm Plus/FSpSo VAD with sound/speech, red/white, composed version

Approval: VdS

Same as 807372RW, but with an individual combination of up to 5 languages, see special order form in the appendix.

 When ordering, please note the "Ordering information for IQ8Quad and IQ8Alarm Plus" and fill in "Order form for individual combination of languages" printed in the appendix. Cancellations or returns are not possible.

 Programmed with 5 languages in accordance with composed combination.

Accessories

806202 IP base, red

807372RW.SV99

NEW



IQ8Alarm Plus/FSpSo VAD with sound/speech, red/white, customized version

Approval: VdS

Same as 807372RW, but with individual texts and/or sounds. The maximum recording time per device is 169 seconds.

 When ordering, please note the "Ordering information for IQ8Quad and IQ8Alarm Plus" and fill in "Order form for individual combination of languages" printed in the appendix. Costs for the recording of customer specific texts and/or tones can be obtained on request. Cancellations or returns are not possible.

 Programmed according to customer specifications.

Accessories

806202 IP base, red

Accessories IQ8Alarm

806201

IQ8Alarm Plus IP 56 base, white



White base, for IQ8Alarm Plus device with protection type IP56 and surface mount cable entry.

Technical Data

Type of protection	IP 56
Color	white, similar to RAL 9010

806202

IQ8Alarm IP 56 base, red



Red base, for IQ8Alarm Plus device with protection type IP56 and surface mount cable entry.

Technical Data

Type of protection	IP 56
Color	red, similar to RAL 3020

767800

Mounting bracket for lintel installation

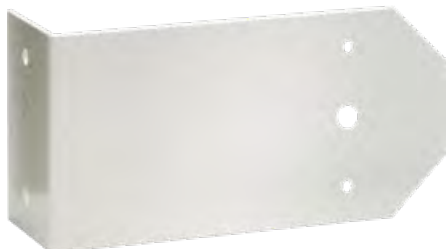

Mounting bracket for all bases/detectors of the IQ8Quad group, series 9x00, RAS 2103 for IQ8Alarm Plus including all alarm devices.

The distance between the mounting holes is 6 cm and the diameter is about 5 mm. Detector side L x W 175 x 90 mm; Wall side H x W 65 x 90 mm.

Technical Data

Material	aluminum
Color	white, similar to RAL 9010



Mounting bracket and installation material

Intrinsically Safe

045040

Ex signaling device DS10, 12 V DC



Features

- 9 tone sequences can be programmed:
- Continuous tone
- Alternating tone
- Intermittent tone
- Siren
- Fire alarm (different national regulations taken into account)

Approval: VdS (FDT)

The sound generator is especially suitable for hazardous industrial areas (zone 2 and 22). The robust aluminum die-cast housing is resistant to chemicals and environmental factors. The DS10 complies with the technical requirements of DIN 33404 - 3 "hazard signals for workplaces".

Technical Data

Ex-category	II 3GD
Explosion protection	EEx nA II T5
Operating voltage	11 ... 14 V DC 10 V DC
Current consumption @ 12 V DC	approx. 300 mA
Sound level	110 dB (A) +/- 3 dB (A)
Ambient temperature	-25 °C ... 55 °C
Storage temperature	-40 °C ... 70 °C
Air humidity	< 90 % (non-condensing)
Type of protection	IP 66, IP 67
Material	aluminum die cast
Color	red, similar to RAL 3000
Weight	approx. 1.95 kg
Specification	EN 54-3
Dimensions	W: 150 mm H: 150 mm D: 143 mm

 According to the conformity declaration, the alarm devices can be used in zones 2 and 22. See tone table on our download website.

766253

Ex sounder, 12 V DC



Features

- 32 tone sequences can be programmed:
- Quartz controlled sound synchronization
- ATEX approved
- LM6 aluminum die-cast housing
- Self-extinguishing aluminum cone, similar to UL 94 VO

KEMA 99 ATEX 7906 design certificate

The ex sounder is especially suitable for application in hazardous areas at industrial workplaces category 2G or 3G (formerly zones 1 and 2) and complies with the technical requirements of DIN 33404 - 3. The robust aluminum die-cast housing is resistant to chemicals and environmental factors.

Technical Data

EC-type examination certificate	KEMA 99ATEX 7906
Explosion protection	II 2G Ex de IIC T4
Operating voltage	12 V DC
Current consumption	typ. 195 mA;
Current consumption @ 12 V DC	approx. 195 mA
Sound level	110 dB(A) ± 3 dB @ 1 m (depending on signaling type)
Ambient temperature	-50 °C ... 55 °C
Storage temperature	-50 °C ... 70 °C
Air humidity	< 90 % (non-condensing)
Type of protection	IP67
Material	aluminum die cast LM6
Color	red, similar to RAL 3000
Weight	approx. 3.16 kg
Dimensions	Ø: 181 mm L: 263 mm

 According to the conformity declaration, the alarm devices can be used in zones 2 and 22. See tone table on our download website.

Remote Indicators

Features

- Shapely, light-weight and compact design
- Prism with all around 180° visible LEDs with a wide area of illumination and high on/off contrast

These indicators are used primarily for signaling alarms of smoke detectors installed above suspended ceilings, between floors or in other inaccessible locations. The indicators have an elegant plastic housing with a clearly visible illuminated field. It comprises two parts - the base which is installed onto a wall or soffit and the lid which is fitted to the base with a clip plug.



Cable length of the remote indicators to detector base or voltage supply max. 100 m.

781814



Features

- 3 continuously or pulsed LEDs
- Power-saving compact indicator

Remote indicator for Series 9000, 9200 and IQ8Quad, red

Red prism is continuously or pulsed illuminated by 3 LEDs.

Technical Data

Operating voltage	1.8 V DC
Current consumption	approx. 9 mA
Alarm display	3 red LEDs
Ambient temperature	-20 °C ... 70 °C
Storage temperature	-35 °C ... 85 °C
Air humidity	< 95 % (non-condensing)
Type of protection	IP 50
Housing	ABS plastic
Color	white, similar to RAL 9010
Weight	approx. 60 g
Dimensions	W: 85 mm H: 82 mm D: 27 mm



Detectors series IQ8Quad

- Standard base Part No. 805590 required for series IQ8Quad
- max. 1 remote indicator per detector
- max. 60 remote indicators per zone (with max. 30 detectors)
- Indicator flashes if activated (Pulse frequency approx. 1 Hz)

801824



Features

- 4 pulsed LEDs
- Ultra power-saving compact indicator
- Powered loop alarm device

Remote indicator esserbus-PLUS for detector series 9200 and IQ8Quad, red

Red prism is illuminated by 4 pulsed LEDs for operation on esserbus and esserbus-PLUS to increase the energy efficiency.

Technical Data

Operating voltage	8 ... 42 V DC
Quiescent current @ 12 V DC	approx. 0.007 mA
Alarm current	150 µA
Frequency of flash	approx. 1.5 Hz
Ambient temperature	-20 °C ... 70 °C
Storage temperature	-35 °C ... 85 °C
Air humidity	< 95 % (non-condensing)
Type of protection	IP 50
Housing	ABS plastic
Color	white, similar to RAL 9010
Weight	approx. 60 g
Dimensions	W: 85 mm H: 82 mm D: 27 mm



Detectors series IQ8Quad

- Standard base Part No. 805590 required for series IQ8Quad
- max. 3 remote indicator per detector
- max. 103 remote indicators per loop



Door Release System

Door Holding Devices
Triggering Devices

212-216
217

1

2

3

4

5

6

7

8

9

10

11

12

13

14

Door Release System

Features

- Low profile design
- Easy cable entry & exit
- Electronic connection via a terminal clamp
- Door retainers have an integrate release button
- The door retainer can be mounted to the wall, to the floor or to the ceiling behind the door. Due to the large product range almost any requirement profile can be met
- The counterpart is the armature (keeper plate) which is mounted on the door
- Door retainer magnets are delivered with a suitable keeper plate
- Electrical Protection IP54
- Anti-remanence pin
- Integrated reverse polarity and spark suppression diode
- Plastic parts consist of Bayblend material with 30% PA6 glass fiber

Automatic Door Systems

Automatic door closing systems for the demarcation of buildings and objects in closed fire compartments for the protection of people and valuables in case of fire.

Automatic door systems consist of triggering devices and locking devices.

In the event of fire, signals created by automatic triggering device cause a release of locking device. Actuation by the manual triggering device also leads to release of locking device.

Fire doors close and prevent the spreading of fires and of any present smoke to bordering areas in a building. This way, fire and dangerous fire aerosols are contained and human life as well as valuables are protected.

Locking device consists of e.g. a clamping magnet with corresponding anchor plate and/or of an automatic door closer. Triggering device consists of a controller, fire detector and release key pushbutton (manual triggering device).

In terms of building directives in Germany, automatic door systems are subject to approval by Deutschen Institut für Bautechnik in Berlin and need a system authorization (for this, see certificates of approval from the DIBt).

The door holding magnets from Honeywell product line are generally vacuum cast and feature IP64 protection class by the basic device.

Door holding magnets are fitted with an integral manual release button, allowing the door to be closed without operating the fire alarm.

All the electromagnets are designed to comply with the latest requirements of EN1155 and DIN EN14637.

Holding Magnets with 400 N Holding Force

The door holding magnets from this product line are generally vacuum cast and feature IP65 protection class by the basic device. The magnets are quality-controlled and are subjected to sampling tests twice per year by the VdS. In addition, all dimensions are in accordance with European specifications and tested in compliance with the EN1155.

960120



Door magnet with release button incl. flexible anchor, 400 N

Release button changeable to the left or right from the base. Cable entry is possible from behind the unit, as well as through the base, left or right side using included grommets. In combination with angled mounting plates the unit can be installed to either floor or wall. Integrated reverse-polarity protection diode and spark suppressing diode.

Technical Data

Operating voltage	24 V DC
Power consumption	1.6 W
Type of protection	IP54 (magnet); IP42 (connection)
Dimensions	W: 85 mm H: 110 mm D: 38 mm
CE certificate	0786-CPD-20435

960121



Door magnet with distance pipe incl. flexible anchor, 400 N, 175 mm

Approval: VdS

Magnet rotary head is fully rotational and is thus suitable for both floor and wall installations. Customer may shorten distance pipe if necessary. Integrated reverse-polarity protection diode and spark suppressing diode. Manual release button on pipe available. Wall distance: 175 mm. Floor distance: 150 mm

Technical Data

Operating voltage	24 V DC
Power consumption	1.6 W
Type of protection	IP54 (magnet); IP42 (connection)
Dimensions	W: 90 mm H: 80 mm Distance: 150/175 mm
CE certificate	0786-CPD-20435

960122

Door magnet with distance pipe incl. flexible anchor, 400 N, 325 mm

As 960121, but with wall distance 325 mm or floor distance 300 mm.

Technical Data

Dimensions	W: 90 mm H: 80 mm Distance: 300/325 mm
------------	--

960130

Door magnet with distance pipe incl. flexible anchor, 400 N, 475 mm

As 960121, but with wall distance 475 mm or floor distance 450 mm.

Technical Data

Dimensions	W: 90 mm H: 80 mm Distance: 450/475 mm
------------	--

960124



Door magnet w/o release button incl. flexible anchor, 400 N

Version with terminal clamp and installation plate. Integrated reverse-polarity protection diode and spark suppressing diode. Suitable for wall installation.

Technical Data

Operating voltage	24 V DC
Power consumption	1.6 W
Type of protection	IP54 (magnet); IP42 (connection)
Dimensions	W: 55 mm H: 55 mm D: 33 mm
CE certificate	0786-CPD-20435

Holding Magnets with 490 N Holding Force

960126



Wall mounted door magnet w/o release button, 490 N

Wall mounted direct current door magnet.

Technical Data

Operating voltage	24 V DC
Power consumption	1.5 W
Dimensions	W: 75 mm H: 116 mm D: 43 mm
Approvals	EN155, CPR, EN14637

767010



Door retainer DH50-N490-WM

Door retainer with polarity reversal protection and connecting terminal including fixing plate for wall mounting.

Technical Data

Operating voltage	24 V DC
Power consumption	1.5 W
Dimensions	Ø: 50 mm H: 30 mm

767017



Door retainer DH50-N490-UM

Holding magnet optionally suitable for floor, ceiling and wall mounting. The anodised aluminium swivel head can be converted from wall to floor or ceiling mounting. The tube can be shortened to 110 or 145 mm (floor/wall mounting).

Technical Data

Operating voltage	24 V DC
Power consumption	1.5 W
Dimensions	W: 90 mm H: 80 mm D: 150 mm (floor mount) W: 90 mm H: 80 mm D: 185 mm (wall mount)

Holding Magnets with 800 N Holding Force

960119



Door magnet with release button incl. flexible anchor, 800 N

Release button changeable to the left or right from the base. Cable entry is possible from behind the unit, as well as through the base, left or right side using included grommets.

In combination with angled mounting plates the unit can be installed to either floor or wall.

Integrated reverse-polarity protection diode and spark suppressing diode.

Technical Data

Operating voltage	24 V DC
Power consumption	2.2 W
Type of protection	IP54 (magnet); IP42 (connection)
Dimensions	W: 85 mm H: 110 mm D: 38 mm
Approvals	EN155, CPR, EN14637

Door Release System

Door Holding Devices

960127



Wall and floor swivel bracket for door magnet 960119 and 960120, angled, 150 mm

This swivel bracket is specially intended for use with 960120 door magnet and thus allows floor or wall installation by means of distance pipe.

Technical Data

Dimensions	W: 100 mm H: 150 mm D: 140 mm
Weight	approx. 0.65 kg

960128



Wall and floor swivel bracket for door magnet 960119 and 960120, angled, 300 mm

As 960127, but with 300 mm pipe length.

Technical Data

Dimensions	W: 100 mm H: 300 mm D: 140 mm
Weight	approx. 1 kg

960129



Floor mounted bracket for door magnet 960119 and 960120

This bracket is especially intended for 960119 and 960120 door magnet. Thus a parallel door installation is possible. Magnet can either be installed within the side panels (to protect from vandalism) or adjacent to the side panels (standard). Due to the increased gauge of steel used, this base is suitable for heavy use (schools etc).

Technical Data

Dimensions	W: 95 mm H: 128 mm D: 80 mm
Weight	approx. 0.65 kg

Explosion-Proof

767153



Ex door magnet, 1588 N

Approval: VdS, TÜV ATEX

Explosion-proof and encapsulated holding magnet for explosion endangered areas. Wall-mounted with cable entry via cable gland.

Technical Data

Operating voltage	24 V DC
Power consumption	3 W
Holding force	1588 N
Ambient temperature	0 °C ... 35 °C
Ex-category	II 2G (gas) and 2D (dust)
Explosion protection	EExme II T6 (gas) and T73 °C IP6X (dust)
Type of protection	IP56
Dimensions	W: 130 mm H: 117 mm D: 106 mm
EC-type examination certificate	TÜV01 ATEX 1778 X



Delivery without anchor plate.



on demand



Approved anchor plates must be used in EX zones.

Keeper Plates

960110

Flexible keeper plate for door magnets, Ø 55 mm



The flexible keeper plate is designed for doors with an angle. The anchor plate is 60° adjustable and fixable in each direction through an articulated joint. The surface is grounded and protected against corrosion.

Technical Data

Weight	approx. 0.15 kg
Dimensions	Ø: 55 mm W: 55 mm H: 55 mm D: 50 mm

960114

Flexible keeper plate for door magnets, Ø 75 mm



The flexible keeper plate is designed for doors with an angle. The anchor plate is 60° adjustable and fixable in each direction through an articulated joint. The surface is grounded and protected against corrosion.

Technical Data

Weight	approx. 0.25 kg
Dimensions	Ø: 75 mm W: 75 mm H: 75 mm D: 55 mm

960115

Flexible keeper plate for door magnets, Ø 75 mm



The flexible keeper plate is designed for doors with an angle. The anchor plate is 60° adjustable and fixable in each direction through an articulated joint. The surface is grounded and protected against corrosion.

Technical Data

Weight	approx. 0.45 kg
Dimensions	Ø: 75 mm W: 75 mm H: 75 mm D: 56 mm

767030

Anchor plate DH50-AP-S

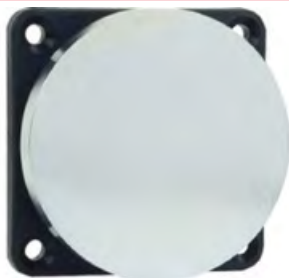

Fixing plate for door retainers with a diameter of 50 mm.

Technical Data

Dimensions	Ø: 50 mm W: 55 mm H: 55 mm D: 18 mm
------------	-------------------------------------

767031

Anchor plate DH70-AP-S

As 767030, but with Ø 70 mm anchor plate.

Technical Data

Dimensions	Ø: 70 mm W: 75 mm H: 75 mm D: 26 mm
------------	-------------------------------------

Release Pushbuttons

767813.10



Surface mount release pushbutton for automatic door release system, German

Surface mount release key for manual actuation of locking devices with double rocker switch insert.

Technical Data

Contact load	250 V AC/10 A
Type of protection	IP44
Housing	ABS plastic
Color	gray, similar to RAL 7035
Weight	approx. 120 g

767814.10



Flush mount release pushbutton for automatic door release system, German

Flush mount release pushbutton for manual actuation of locking devices with double rocker switch insert.

Technical Data

Contact load	250 V AC/10 A
Type of protection	IP44
Housing	ABS plastic
Color	white
Weight	approx. 95 g

796349

Label for release pushbutton

Red sticker label for release pushbutton 767813.10 and 767814.10.



 10 pcs

Notes

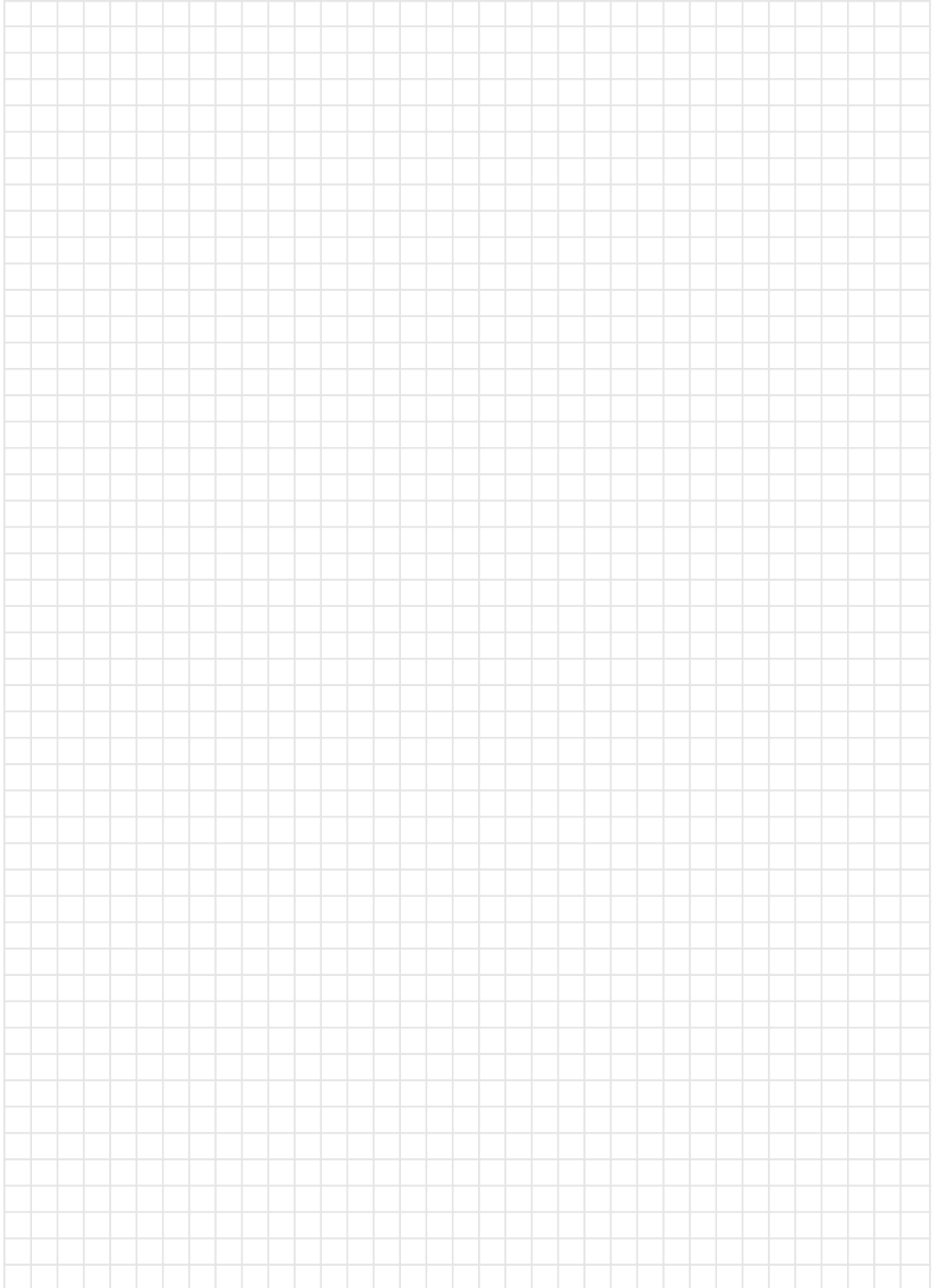



Installation & Service

Installation Accessories
Housings

220-224
225-226

1

2

3

4

5

6

7

8

9

10

11

12

13

14

Surge Protection

764730



OVP module for TTY interfaces and conventional zones

Overvoltage protection module as 4-pin, rail-mounted device. Space-saving combined surge protector module for the protection of two wire pairs of symmetrical interfaces with electrical isolation.

Technical Data

Rated voltage	24 V
Rated current	1 A @ 45 °C
max. cont. operating voltage a.c.	23.3 V AC
max. cont. operating voltage d.c.	33 V DC
Nom. discharge current (80/20)/line	10000 A
Total nom. discharge current	20 kA
Total lightning imp. current (10/350)	10 kA
Lightning imp. current (10/350)/line	2.5 kA
Ambient temperature	-40 °C ... 85 °C
Air humidity	< 95 % (non-condensing)
Type of protection	IP 20

 Low resistance ground connection is a must for proper surge protection functioning.

Accessories

764737 Base for overvoltage protection module

764731



OVP module for essernet and RS485 interfaces

Space-saving combined surge protector with LifeCheck for the protection of one wire of radio-frequency bus systems, with either direct or indirect shield grounding.

Technical Data

Rated voltage	5 V
Rated current	1 A @ 45 °C
max. cont. operating voltage a.c.	4.2 V AC
max. cont. operating voltage d.c.	6 V DC
Nom. discharge current (80/20)/line	10000 A
Total nom. discharge current	20 kA
Total lightning imp. current (10/350)	9 kA
Lightning imp. current (10/350)/line	2.5 kA
Ambient temperature	-40 °C ... 85 °C
Air humidity	< 95 % (non-condensing)
Type of protection	IP 20

Accessories

764737 Base for overvoltage protection module

764732





OVP module including base support for 230 V power supply line

Two-pin surge protector comprising base element and connected protection module, with potential-free telecommunications contact for independent fault forwarding.

Technical Data

Rated voltage	230 V AC
max. cont. operating voltage a.c.	255 V AC
max. cont. operating voltage d.c.	255 V DC
Nominal load current a.c.	25 A
Total discharge current (8/20) [L+N-PE]	5 kA
Combined impulse	6 kV
Combined impulse [L+N-PE]	10 kV
Voltage protection level [L/N-PE]	≤ 1500 V
Voltage protection level [L-N]	≤ 1250 V
Response time [L/N-PE]	≤ 100 ns
Response time [L-N]	≤ 25 ns
Ambient temperature	-40 °C ... 85 °C
Air humidity	< 95 % (non-condensing)
Type of protection	IP 20

 Low resistance ground connection is a must for proper surge protection functioning.

 Base element and connected protection module

764733

OVP module for esserbus/esserbus-PLUS loop



Space-saving combined surge protector module for the protection of two wire pairs symmetrical interfaces with electrical isolation.
Two overvoltage protection module of this type is required for each loop.

Technical Data

Rated voltage	48 V
Rated current	1 A @ 45 °C
max. cont. operating voltage a.c.	38.1 V AC
max. cont. operating voltage d.c.	54 V DC
Nom. discharge current (80/20)/line	10000 A
Total nom. discharge current	20 kA
Total lightning imp. current (10/350)	10 kA
Lightning imp. current (10/350)/line	2.5 kA
Ambient temperature	-40 °C ... 85 °C
Air humidity	< 95 % (non-condensing)
Type of protection	IP 20 (connected)

Accessories

764737 Base for overvoltage protection module

764734

OVP module



Space-saving combined surge protector module for the protection of one wire pair of symmetrical interfaces with electrical isolation.

Technical Data

Rated voltage	180 V
Rated current	0.75 A @ 45 °C
max. cont. operating voltage a.c.	127 V AC
max. cont. operating voltage d.c.	180 V DC
Nom. discharge current (80/20)/line	10000 A
Total nom. discharge current	20 kA
Total lightning imp. current (10/350)	5 kA
Lightning imp. current (10/350)/line	2.5 kA
Ambient temperature	-40 °C ... 85 °C
Air humidity	< 95 % (non-condensing)
Type of protection	IP 20 (connected)

Accessories

764737 Base for overvoltage protection module

764736

OVP module for control outputs



Power-coordinated combined surge protector for the protection of ungrounded DC power supplies for mounting-rail installation.
Protection of monitored and potential-free control outputs up to 36 volts.

Technical Data

Rated voltage	36 V
Rated current	7 A @ 40 °C
max. cont. operating voltage d.c.	45 V DC
Nom. discharge current (80/20)/line	10000 A
Total nom. discharge current	20 kA
Total lightning imp. current (10/350)	5 kA
Lightning imp. current (10/350)/line	2.5 kA
Ambient temperature	-40 °C ... 85 °C
Air humidity	< 95 % (non-condensing)
Type of protection	IP 20

 No base support is required for the connection.

764737



Base module for OVP modules

Base part as very space-saving, 4-pin, universal feed-through terminal to accommodate the surge protector module without signal interruption. The secure grounding of the surge protector module is established via the mounting rail support base by means of a snap-on attachment. As no components of the protection circuit are located in the base part, maintenance work is restricted to the protection modules.

Technical Data

Ambient temperature	-40 °C ... 85 °C
Air humidity	< 95 % (non-condensing)
Type of protection	IP 20

 Tool-free attachment on 35 mm mounting rails.

Junction Box Module

382040

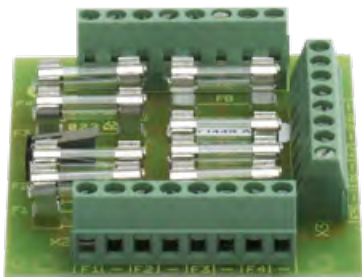

8-fuse-card

Approval: VdS

Fuse card with 8 x 0.5 A fuses for individual power supply protection of each area, zone and component. It can be used with all ESSER mains units, fire and intrusion detection panels.

Technical Data

Contact load	30 V DC / 1 A
Connection terminal	0.6 mm to max. 1.5 mm ²
Ambient temperature	-5 °C ... 50 °C
Storage temperature	-25 °C ... 75 °C
Air humidity	< 95 % (non-condensing)
Weight	approx. 85 g
Dimensions	W: 65 mm H: 72 mm D: 15 mm

 Possible installation in housings: Part No. 120240, 120242, 120244, 788600, 788601, 788650, 788650.10, 788651, 788651.10, 788603 and 788603.10

Accessories

050510



Network interference suppression filter type 2VK3

The mains interference suppression filter is intended for later installation in all mains-operated devices in which problems due to HF power failure arise.

Technical Data

Rated voltage	115 V-250 V AC
Rated current	2 A
Rated frequency	50 ... 60 Hz
Ambient temperature	-10 °C ... 40 °C
Dimensions	W: 52.6 mm H: 46 mm D: 23.1 mm (without flange)



Mains interference suppression filter and terminal block

788602



Top-hat rail

Technical Data

Dimensions	L: 400 mm
------------	-----------



Mounting kit

788652



Mounting rail for FACP

The top hat rail installation kit can be retrofitted into the IQ8Control and FlexES Control unit housing. The hat rail is fitted to the mounting board via two screws. A maximum of two (Part No. 788603.10) module housings (option) can be mounted to the control unit housing.

Technical Data

Dimensions	L: 35 mm W: 175 mm (standard-snap-on mounting rail)
------------	---



Mounting rail and accessories

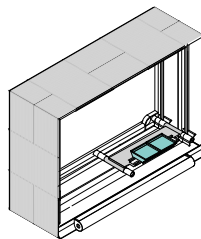

Application example

788603.10

Module housing for top-hat mounting rail



For snap-on mounting rail of several electronic modules with 82 x 72 mm PCB size. Angled cable entry.

Technical Data

Material	plastic
Color	green

 1 x UM-profile and 2x side panels



Application example with transponder

788605

Mounting kit

Mounting kit required for mounting esserbus transponders in extension housings.



 4 x spacer bolts and 2 x fixing screws

704147

Cable gland M12 with nut

Polyamide cable gland to increase the protection level.



Technical Data

Ambient temperature	-20 °C ... 95 °C
Type of protection	IP 67
Material	Polyamide
Color	gray
Cable diameter	3 mm

704148

Cable gland M16 with nut

Polyamide cable gland to increase the protection level.



Technical Data

Ambient temperature	-20 °C ... 95 °C
Type of protection	IP 67
Material	Polyamide
Color	gray
Cable diameter	8 mm

Housings

788600

Housing surface mount, gray



Small distributor housing for esserbus transponders.

The following esserbus transponder types can be used:

- 2 esserbus transponders each of dimensions (W x H x D) 82 x 72 x 20 mm
- 1 esserbus transponder of dimensions (W x H x D) 150 x 82 x 20 mm

Technical Data

Type of protection	IP 40
Material	ABS
Color	gray, similar to RAL 7035
Dimensions	W: 189 mm H: 131 mm D: 47 mm

788601

Housing flush mount, gray



Same as 788600, but flush-mounted version.

Technical Data

Type of protection	IP 40
Material	ABS
Color	gray, similar to RAL 7035
Dimensions	W: 189 mm H: 131 mm D: 47 mm W: 207 mm H: 149 mm (cover)

788650.10

Housing surface mount, white



Same as 788600, but white.

Technical Data

Type of protection	IP 40
Material	ABS
Color	white, similar to RAL 9003
Dimensions	W: 189 mm H: 131 mm D: 47 mm

788651.10

Housing flush mount, white



Same as 788601, but white.

Technical Data

Type of protection	IP 40
Material	ABS
Color	white, similar to RAL 9003
Dimensions	W: 189 mm H: 131 mm D: 47 mm W: 207 mm H: 149 mm (cover)

788655



IP55 base adapter for 788656

IP base adapter for extreme environmental conditions.

Technical Data

Type of protection	IP55
--------------------	------

788656





High IP housing

Housing for esserbus transponder to increase IP rating in connection with 788655.

Technical Data

Type of protection	IP55
--------------------	------

 Housing + front cover

 788655 base must be ordered separately for IP55 protection.

M200SMB

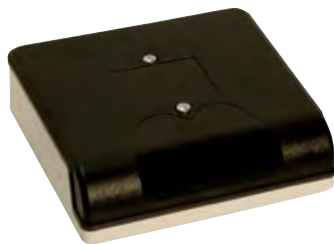

Surface mounting housing for one IQ8FCT XS module

Surface enclosure for one module with semi-transparent cover to see module label, address and LED.

Technical Data

Dimensions	H: 143mm W: 130 mm D: 49 mm
------------	-----------------------------

SMB6-V0



Surface mount housing for 6 IQ8FCT XS modules

Surface enclosure for 6 modules with semi-transparent cover to see module address and LEDs.

Technical Data

Dimensions	H: 180 mm W: 245 mm D: 100 mm
------------	-------------------------------



Appendix

Planning Guide	228
Order Forms	229-236
Part Number Index	237-239
Index	240-247

Planning Guide for Loop Installation

This is a planning guide for loop-powered alarm devices.

The alarm current of each alarm device is defined as a load factor. When added up, the total load factor defines the loop length and the maximum number of alarm devices.

The maximum load factor of all alarm devices may not exceed 96. Altogether up to 127 bus devices per loop can still be connected. The "load factor" download file for easier load factor calculation is available within our customer section at <http://www.esser-system.com>. The examples shown below refer to a wire diameter of 0.8 mm.

The Excel spread sheet for downloading contains as well the maximum powered loop length for wires with a cross section of 1.0, 1.5, 2.5 mm².

Load factors:

Part No.	Type of alarm signaling device	Load factor
802382	O/So optical smoke detector IQ8Quad with isolator.....	2
802383	O ² T/F multisensor fire detector IQ8Quad with isolator	2
802384	O ² T/So multisensor fire detector IQ8Quad with isolator	2
802385	O ² T/FSp multisensor fire detector IQ8Quad with isolator.....	3
802386	O ² T/Sp multisensor fire detector IQ8Quad with isolator	3
807205	IQ8Alarm/So signaler with isolator, white.....	3
807206	IQ8Alarm/So signaler with isolator, red	3
807212	IQ8Alarm/F signaler with isolator, amber flash.....	3
807213	IQ8Alarm/F signaler with isolator, blue/green/white flash	3
807214	IQ8Alarm/F signaler with isolator, red flash.....	3
807322	IQ8Alarm/Sp signaler with isolator, white.....	3
807224	IQ8Alarm/FSo signaler with isolator, red.....	3
807332	IQ8Alarm/Sp signaler with isolator, red	3
807372	IQ8Alarm/FSp signaler with isolator, red.....	3

Table 1.1: Maximum loop length depending on the total load factor

Maximum powered loop length	Total load factor
up to 700 m.....	91 up to 96
up to 800 m.....	85 up to 90
up to 900 m.....	79 up to 84
up to 1,000 m.....	73 up to 78
up to 1,100 m.....	67 up to 72
up to 1,300 m.....	61 up to 66
up to 1,500 m.....	55 up to 60
up to 1,700 m.....	49 up to 54
up to 2,000 m.....	43 up to 48
up to 2,500 m.....	37 up to 42
up to 3,000 m.....	31 up to 36
up to 3,500 m.....	1 up to 30

Example 1:

How many IQ8Alarm alarm signaling devices with load factor 3.0 can be connected to one analog loop?

Max. total load factor 96 : 3.0 (load factor) = up to 32 pcs. IQ8Alarm devices can be connected to each loop depending on the loop length (up to 700 m at a wire gauge 0.8 mm)

Example 2:

Various types of alarm signaling devices are connected to one loop:

	Load factor	
4 x 807205 alarm devices with load factor 3.0	= 4 x 3.0	= 12
		+
27 x O ² T/So multisensor fire detector IQ8Quad (802384) with load factor 2.0	= 27 x 2.0	= 54

total load factor = 66

As shown in table 1.1, the maximum loop length for a total load factor of 66 is 1,300 m (at a wire gauge 0.8 mm)

Example 3:

For alarm signaling with sounder, 25 x 802384 IQ8Quad O²T/So detectors are installed - each in one office. What is the maximum loop length?

Load factor for one 802384 IQ8Quad O²T/So detector = 2 (load factor)

25 pcs. IQ8Quad O²T/So x 2 (load factor)





total load factor = 50

As shown in table 1.1, the maximum loop length is 1,700 m (at a wire gauge 0.8 mm)

















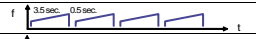

Order Information for Alarm Signaling Devices IQ8Quad and IQ8Alarm - composed combination of other languages and customized version

- The IQ8Quad O²T/FSp multisensor fire detector (Part No. 802385) and the IQ8Alarm "Combi" Speech Alarm (Part No. 802385) can also be ordered with a different combination of languages.

The following five languages are the programmed standard for these speech alarms. The respective languages are assigned with the five standard speech announcements for the IQ8Quad (Part No. 802385) and the IQ8Alarm (Part No. 807372).

Country code acc. to ISO 3166 -Alpha-2	Language code acc. to ISO 639-1	Evacuation 1	Evacuation 2	Alarm	Test message	All-Clear
 Germany (DE)	de	Dies ist ein Feueralarm. Bitte verlassen Sie das Gebäude umgehend über die nächsten Fluchtwege. Die Feuerwehr ist alarmiert.	Achtung, Achtung! Dies ist eine Gefahrenmeldung. Bitte verlassen Sie das Gebäude über die nächsten Ausgänge.	Achtung, im Gebäude ist eine Gefahrensituation gemeldet worden. Bitte bleiben Sie ruhig, und warten Sie auf weitere Anweisungen.	Dies ist eine Testdurchsage.	Die Gefahrensituation ist jetzt behoben. Wir entschuldigen uns für jegliche Unannehmlichkeiten.
 Great Britain (GB)	en	This is a fire alarm. Please leave the building immediately by the nearest available exit.	Attention please. This is an emergency. Please leave the building by the nearest available exit.	An incident has been reported in the building. Please await further instructions.	This is a test message. No action is required.	The emergency is now cancelled. We apologize for any inconvenience.
 France (FR)	fr	Ceci est une alarme incendie, veuillez évacuer immédiatement les locaux par la sortie la plus proche.	Votre attention s'il vous plait, ceci est une alarme. Veuillez évacuer les locaux par la sortie la plus proche.	Un incident est signalé dans le bâtiment. Merci de garder votre calme et attendez les prochaines instructions.	Ceci est un test.	L'alarme est à présent annulée. Veuillez nous excuser pour le désagrément.
 Spain (ES)	es	Esto es una alarma de incendio. Abandonen por favor el edificio inmediatamente por la salida de evacuación más cercana.	Atención. Esto es una emergencia. Por favor abandonen el edificio por la salida de evacuación más cercana.	Atención, se ha reportado un incidente en el edificio. Esperen por favor otras instrucciones.	Esto es un mensaje de prueba. No se requiere ninguna acción.	La emergencia ha sido cancelada. Pedimos disculpas por las molestias causadas.
 Italy (IT)	it	Attenzione. Allarme incendio. Abbandonare l'edificio tramite l'uscita di emergenza più vicina.	Attenzione. Allarme in corso. Vi preghiamo di recarvi presso l'uscita di emergenza più vicina.	Attenzione. E' stato rilevato un allarme. Ulteriori disposizioni vi verranno comunicate appena possibile.	Attenzione. E' in corso una prova di allarme. Non è richiesta alcuna azione.	Attenzione. Cessato allarme. La situazione di normalità è stata ripristinata.

Standard speech messages of IQ8Quad detectors and IQ8Alarm

No.	Description	Frequency	Pulse rate
1	School bell	complex	complex
2	FP 1063.1 Telecoms BS 5839 Pt1	Alternating 800 / 970 Hz at 2 Hz	
3	BS 5839 Pt1	Alternating 800 / 970 Hz at 1 Hz	
4	BS 5839 Pt1	Intermittent 970 Hz at 1 Hz 0.5 sec.	
5	BS 5839 Pt1	Intermittent 2850 Hz at 1 Hz 0.5 sec.	
6	BS 5839 Pt1	Intermittent 970 Hz 1/4 sec. ON - 1 sec. OFF	
7	BS 5839 Pt1	Continuous 970 Hz	
8	BS 5839 Pt1	Sweep tone 800 Hz tp 970 Hz at 7 Hz	
9	BS 5839 Pt1	Sweep tone 800 Hz to 970 Hz at 1 Hz	
10	DIN Tone DIN 33404 Part 3	1200 - 500 Hz at 1 Hz	
11	French fire sound	554 Hz / 100 ms + 440 Hz / 400 ms + 10 %	
12	NL - Slow Whoop	500 Hz - 1200 Hz at 3.5 sec. break of 0.5 sec.	
13	US - Horn	Continuous 485 Hz	
14	US - Horn with Temporal Pattern	Intermittent 485 Hz (0.5 sec. ON; 0.5 sec. OFF; 3 times; 1.5 sec. OFF; Repeat)	
15	US - March Time	Alternating 485 Hz (0.25 sec. ON; 0.25 sec. OFF; Repeat)	
16	US - Slow Whoop	Sweep tone 500 Hz to 1200 Hz (4.0 sec. ON; 0.5 sec. OFF; Repeat)	
17	US - Siren	Sweep tone 600 Hz to 1200 Hz (1.0 sec. ON; Repeat)	
18	US - Hi/Lo	Alternating 100 Hz / 800 Hz (0.25 sec. ON; Alternate; 0.25 sec. ON; Alternate; Repeat)	
19	US - NFPA Whoop	Sweep tone 422 Hz to 775 Hz (upwards sweep 0.85 sec.; 3 times; 1 sec. OFF; Repeat)	
20	IMO GA-Signal	Intermittent 800 Hz (1.0 sec. ON; 1.0 sec. OFF; 7 times; 2.0 sec. OFF; Repeat)	

IQ8Quad detectors and IQ8Alarm tone table

Order Information: Composed Combination of Languages (xy.SV98)

Up to five languages can be provided per alarm signaling device.

Other combinations of languages can be ordered with the "Order Form for IQ8 Composed Languages (xy.SV98)".

The delivery time is approximately four weeks.

Please note that returns or cancellations are not possible!

Part Nos. for individual combination of languages

O ² T/FSp multisensor fire detector IQ8Quad with isolator, composed version	802385.SV98
O ² T/Sp multisensor fire detector IQ8Quad with isolator, composed version	802386.SV98
IQ8Alarm Plus/SpSo sounder with speech, red, composed version	807322R.SV98
IQ8Alarm Plus/SpSo sounder with speech, white, composed version	807322W.SV98
IQ8Alarm Plus/FSpSo visual alarm device with sound/speech, red/red, composed version	807372RR.SV98
IQ8Alarm Plus/FSpSo visual alarm device with sound/speech, red/white, composed version	807372RW.SV98



Description:

Individual combination of languages

For example:

Phrase 1 - 5 NL_nl
 Phrase 6 - 10 GB_en
 Phrase 11 - 15 DE_de
 Phrase 16 - 20 TR_tr
 Phrase 21 - 25 RU_ru

The message type per language is always the same as mentioned in the chart

"Additional languages for IQ8 composed versions":

- 1 Evacuation 1
- 2 Evacuation 2
- 3 Alarm
- 4 Test message
- 5 All-Clear

Additional Languages for IQ8 Composed Version (xy.SV98) Page 1/2

Country code acc. to ISO 3166 -Alpha-2	Language code acc. to ISO 639-1	Evacuation 1	Evacuation 2	Alarm	Test Message	All-Clear
SA  Arabia	ar	حريق مناك الانتباه يرجى اقرب الى التوجه الزجاء المبنى اخلاء و طواريه مخرج	- - -	في طاريه وقوع عن الابلاغ تم الانتظار يرجى المبنى ارشادات على للحصول	النظام لفحص الرساله هذه للازعاج ناسف	الطواريه حالة الغاء تم ازعاج اي عن تعتذر الان
BA  Bosnia	bs	Ovo je požarni alarm Molimo da odmah napustite zgradu koristeći najbliži raspoloživi izlaz.	Pažnja. Ovo je obavještenje o opasnosti. Molimo napustite zgradu koristeći najbliži raspoloživi izlaz.	U zgradi se dogodio incident. Molimo sačekajte dalja uputstva.	Ovo je poruka za ispitivanje sistema. Možete nastaviti sa vašim aktivnostima.	Opasnost je prestala. Izvinjavamo se radi eventualnih neugodnosti.
BR  Brasil	pt	Atenção. Esta é uma emergência. Por favor, abandonem o edifício pela saída de emergência mais próxima.	Isto é um alarme de incêndio. Abandonem por favor, o edifício imediatamente pela saída de emergência mais próxima	Atenção foi reportado um incidente no edifício. Aguardem, por favor, outras instruções.	Esta é uma mensagem de teste. Não se requer nenhuma ação.	A emergência foi cancelada. Pedimos desculpas pelos problemas causados
CN  China Mandarin	zh	请注意！ 请注意！ 现在发生火警， 请保持冷静， 请尽快离开现场！	请注意！ 请注意！ 现在发生火警， 请留意广播， 或注意现场指示！	请注意！ 现在发生紧急事故， 请等待下一步指示。	注意！ 紧急事故已经排除， 谢谢！	现在是系统测试， 请各位无需惊慌。
DK  Denmark	da	Brandalarmen er aktiveret forlad venligst bygningen, anvend nærmeste nødudgang.	Dette er en nødsituation, forlad bygningen brug de opmærkede flugtveje.	Et varsel om brand bliver undersøgt, afvent nærmere besked.	Dette er en test melding ingen tiltag nødvendig.	Normal tilstand er genoprettet, faren er overstået.
FI  Finland	fi	Huomio, kiinteistöissä on havaittu automaattinen paloilmotus. Poistu rakennuksesta käyttäen ohjattuja reittejä. Hissien käyttö on kielletty.	Huomio, turvallisuusyöstä kiinteistöistä on poistuttava välittömästi. Käytä ohjattuja reittejä.	Huomio, paloilmotin on ilmoittanut mahdollisesta vaaratilanteesta. Tutkimme asiaa ja annamme pian lisätietoja.	Paloilmotinjärjestelmää testataan.	Palohälytys on ohi. Tilanne on palautunut normaaliksi.
GR  Greece	el	Αυτό είναι ένα μήνυμα συναγερμού για πυρκαγιά. Παρακαλώ εγκαταλείψτε το κτίριο αμέσως από τις εξόδους κινδύνου. Η πυροσβεστική έχει δοπονηθεί.	Προσοχή, προσοχή! Αυτό είναι ένα μήνυμα για κατάσταση κινδύνου. Παρακαλώ εγκαταλείψτε το κτίριο από τις επόμενες εξόδους.	Προσοχή στο κτίριο υπάρχει κατάσταση κινδύνου. Παρακαλώ παραμείνετε ψύχραιμοι και περιμένετε επόμενες οδηγίες.	Αυτή είναι μια δοκιμαστική ανακοίνωση.	Η κατάσταση κινδύνου έχει αρθεί. Ζητούμε συγγνώμη για τυχόν δυσάρεστες καταστάσεις που προκλήθηκαν.
ES  Catalonia	ca	Això és una alarma d'incendi. Siusplau abandonin l'edifici immediatament per la sortida d'evacuació més propera.	Atenció. Això es una emergencia. Siusplau abandonin l'edifici per la sortida d'evacuació més propera.	Atenció. S'ha notificat un incident a l'edifici. Siusplau, esperin altres instruccions.	Això es un missatge de prova. No es requereix cap acció.	L'alarma ha estat cancel.lada. Preguem disculpin les molesties.
HR  Croatia	hr	Ovo je požarni alarm. Molimo odmah napustite objekt koristeći najbliži izlaz za nuzdu. Vatrogasna postaja je alarmirana.	Pozor! Pozor! Ovo je priopćenje o neposrednoj opasnosti. Molimo odmah napustite objekt koristeći najbliži izlaz za nuzdu.	Pozor! U objektu je prijavljena opasnost. Molimo ostanite mirni i pričekajte daljnje upute.	Ovo je probno priopćenje. Nikakve mjere nisu neophodne.	Opasnost je prestala. Ispricavamo se radi eventualnih neugodnosti.
NL  Netherlands	nl	Attentie, er is een brandalarm. Verlaat het gebouw via de dichtstbijzijnde uitgang.	Attentie, er is een calamiteit. Verlaat het gebouw via de dichtstbijzijnde uitgang.	Attentie, er volgt een busing, verlaat de ruimte.	Dit is een testalarm, dit is een testalarm.	Einde alarmmelding, einde alarmmelding.
NO  Norway	no	Brannalarmen er utløst, forlat bygget, bruk de oppmerkede rømningsveiene.	Dette -er en nødsituasjon, forlat bygget, bruk de oppmerkede rømningsveiene.	Et automatisk varsel om brann blir undersøkt, avvent nærmere beskjed.	Dette er en testmelding, ingen tiltak nødvendig.	Normaltilstand er gjenopprettet, faren er over.

Additional Languages for IQ8 Composed Version (xy.SV98) Page 2/2

Country code acc. to ISO 3166 -Alpha-2	Language code acc. to ISO 639-1	Evacuation 1	Evacuation 2	Alarm	Test Message	All-Clear
 Poland	pl	Uwaga! Wystąpił alarm pożarowy. Proszę natychmiast opuścić budynek najbliższym dostępnym wyjściem ewakuacyjnym.	Proszę o uwagę! To jest komunikat alarmowy. Proszę opuścić budynek najbliższym dostępnym wyjściem ewakuacyjnym.	Uwaga. W budynku wystąpiło zdarzenie alarmowe. Proszę spokojnie oczekiwać dalszych instrukcji.	To jest komunikat testowy. Nie są wymagane żadne działania.	Stan alarmu został odwołany. Przepraszamy za wszelkie niedogodności i utrudnienia.
 Portugal	pt	Isto é um alarme de incêndio. Por favor abandonem o edifício imediatamente pela saída de evacuação mais próxima.	Atenção. Isto é uma emergência. Por favor abandonem o edifício pela saída de emergência mais próxima.	Atenção, ocorreu um incidente no edifício. Por favor aguardem mais instruções.	Atenção, isto é apenas um ensaio	O alarme foi cancelado. Queiram desculpar o inconveniente.
 Romania	ro	Atențiune, atențiune! S-a declanșat o alarmă de incendiu. Vă rugăm părăsiți imediat clădirea pe cea mai apropiată cale de evacuare. Alarma a fost transmisă la pompieri.	Atențiune! Acesta este un mesaj de urgență. Vă rugăm părăsiți clădirea pe cea mai apropiată cale de ieșire.	Atențiune. În clădire a fost semnalat un incident. Vă rugăm să vă păstrați calmul și să așteptați noi instrucțiuni.	Situația de urgență a luat sfârșit. Ne cerem scuze pentru eventualele inconveniente.	Acesta este un mesaj de test.
 Serbian	sr	Ovo je požarni alarm! Molimo vas da odmah napustite zgradu koristeći najbliži raspoloživi izlaz.	Pažnja! Ovo je obaveštenje o opasnosti. Molimo vas da naпустите zgradu koristeći najbliži raspoloživi izlaz.	U zgradi se desio incident. Molimo vas da sečekate dalja uputstva.	Ovo je poruka za ispitivanje sistema. Možete nastaviti sa vašim aktivnostima.	Opasnost je prestala. Izvinjavamo se zbog eventualnih neugodnosti.
 Russia	ru	Внимание. Пожарная тревога. Пожалуйста покиньте помещение через ближайшие аварийные выходы.	Внимание. Это предупреждение о пожарной опасности. Пожалуйста покиньте помещение через ближайшие выходы.	Внимание. Поступило предупреждение о пожарной опасности. Пожалуйста сохраняйте спокойствие и ждите дальнейшей информации.	Отмена пожарной тревоги. Ситуация нормализовалась. Извините за причинённые неудобства.	Тестовое сообщение. Идет проверка системы пожарной сигнализации.
 Sweden	sv	Brandlarmet är utlöst, lämna omedelbart byggnaden genom närmaste utgång.	Detta är en nödsituation, lämna omedelbart byggnaden genom närmaste utgång.	Larm om brand i byggnaden blir undersökt, invänta närmare besked.	Detta är ett testmeddelande, ingen åtgärd är nödvändig.	Normalt tillstånd är återupprättat, faran är över.
 Slovakia	sk	Toto je požiarňy poplach. Opusťte prosím okamžite budovu najbližším núdzovým východom!	Pozor, hrozí nebezpečenstvo. Opusťte prosím budovu najbližším núdzovým východom!	V budove bola vyhlásená pohotovosť. Počkajte prosím na ďalšie pokyny.	Toto je testovacie hlásenie. Nie je potrebné naň reagovať.	Pohotovosť bola odvolaná. Ospravedlňujeme sa za prípadné ťažkosti.
 Slovenia	sl	Požarni alarm! Prosimo takoj zapustite zgradbo skozi najbližji izhod. Gasilci so obveščeni.	Pozor! Pozor! To je sporočilo o nevarnosti. Prosimo zapustite zgradbo skozi najbližji izhod!	Pozor, v zgradbi je zaznana nevarnost. Prosimo ostanite mirni in počakajte na nadaljnja navodila.	To je testno sporočilo.	Nevarna situacija je obvladana. Opravičujemo se za vse neprijetnosti.
 Czech Republic	cs	Toto je požární poplach. Prosim, opusťte okamžitě budovu nejbližším únikovým východem.	Pozor, hrozí nebezpečí. Prosim, opusťte budovu nejbližším únikovým východem.	V budově byla vyhlášena pohotovost. Prosim, vyčkejte dalších instrukcí.	Toto je testovací hlášení. Není třeba na něj reagovat.	Pohotovost je nyní odvolána. Omlouváme se za případné obtíže.
 Turkey	tr	Acil bir durum var. Lütfen binayı en yakın çıkış noktasından terkedin	Acil bir durum var. Lütfen binayı en yakın çıkış noktasından terkedin.	Bu bir yangın uyarısıdır. Bu bir yangın uyarısıdır. Talimatlar için beklemede kalın. Talimatlar için beklemede kalın.	Yangın uyarısı test edilmektedir. Bir şey yapmanız gerekmiyor. Bir şey yapmanız gerekmiyor.	Tehlike geçmiştir. Tehlike geçmiştir. Bir şey yapmanız gerekmiyor.
 Hungary	hu	Tűzriadó! Kérem, azonnal hagyják el az épületet az Önökhöz legközelebb eső kijáraton!	Figyelem! Vészhelyzet! Kérem, azonnal hagyják el az épületet az Önökhöz legközelebb eső kijáraton!	Az épületben váratlan esemény történt. További utasításig kérem várjanak!	Ez egy teszttüzenet.	Vészhelyzet törölve. Az esetleges kellemetlenségéért elnézésüket kérjük.

Order Form for IQ8 Composed Languages (xy.SV98)

Honeywell Life Safety Austria GmbH

Fax +43 1 600 6030-900
hls-austria@honeywell.com

Customer Data Please fill out the following form for the registration of these data.

Company:	Customer ID:
Street:	Zip Code/City:
Contact Person:	E Mail:
Telephone:	Fax:
Order Number/Order Text:		
Object:		

Order Combined Version

- ___ pcs. **802385.SV98** O2T/FSp multisensor detector IQ8Quad with composition of other languages
- ___ pcs. **807386.SV98** O2T/Sp multisensor IQ8Quad, special language
- ___ pcs. **807322W.SV98** IQ8Alarm Plus/SpSo sounder with speech, white, composed version
- ___ pcs. **807332R.SV98** IQ8Alarm Plus/Sp sounder with speech, red, composed version
- ___ pcs. **807372RR.SV98** IQ8Alarm Plus/FSpSo VAD with sound/speech, red/red, composed version
- ___ pcs. **807372RW.SV98** IQ8Alarm Plus/FSpSo VAD with sound/speech, red/white, composed version

Languages

Choose max. 5 languages	Country Code acc. to ISO 3166	Language Code acc.to ISO 639-1
___ Arabic	SA	ar
___ Bosnian	BA	bs
___ Catalan	ES	ca
___ Chinese Mandarin	CN	zh
___ Croatian	HR	hr
___ Czech	CZ	cs
___ Danish	DK	da
___ Dutch	NL	nl
___ English	GB	en
___ Finnish	FI	fi
___ French	FR	fr
___ German	DE	de
___ Greek	GR	el
___ Hungarian	HU	hu
___ Italian	IT	it
___ Norwegian	NO	no
___ Polish	PL	pl
___ Portuguese	PT	pt
___ Portuguese/Brazil	BR	pt
___ Romanian	RO	ro
___ Russian	RU	ru
___ Serbian	RS	sr
___ Swedish	SE	sv
___ Slovak	SK	sk
___ Slovenian	SL	sl
___ Spanish	ES	es
___ Turkish	TR	tr

Repeat Orders or Additions

For repeat orders or additions please give the Order No. or the serial number of the detector with special languages.

Order Number:

Serial Number:

.....
Date/Signature

To be filled out by Honeywell Life Safety Austria GmbH: Please forward to Novar GmbH when filled out!
Order number:
Position:

Order Information: Customized Combination of Languages (xy.SV99)

In case you should need customized texts differing from the standard speech messages or composed versions or you should need additional signal tones or other languages which are not listed in the standard order form please use the "**Order Form for IQ8 Customized Languages (xy.SV99)**".

The maximum recording time is 169 seconds.

Information about delivery time and price of recording customized announcements/signal tones are available upon request.

Please note that returns or cancellations are not possible!

Part Nos. for customized programming of specific announcements/signal tones

O ² T/FSp multisensor fire detector IQ8Quad with isolator, customized version	802385.SV99
O ² T/Sp multisensor fire detector IQ8Quad with isolator, customized version	802386.SV99
IQ8Alarm Plus/SpSo sounder with speech, red, customized version	807322R.SV99
IQ8Alarm Plus/SpSo sounder with speech, white, customized version	807322W.SV99
IQ8Alarm Plus/FSpSo visual alarm device with sound/speech, red/red, customized version	807372RR.SV99
IQ8Alarm Plus/FSpSo visual alarm device with sound/speech, red/white, customized version	807372RW.SV99



Description:
Customer specific announcements/signals

For example:

Phrase 1 - 5	NL_nl
Phrase 6 - 10	GB_en
Phrase 11 - 15	DE_de
Phrase 16 - 20	TR_tr
Phrase 21 - 25	RU_ru
Phrase 26 - 31	Extra

(customer specific texts / special tones)



The programming of speech and/or tone data is carried out at the factory according to your specifications. The programming of the customer data is carried out via the tools 8000 programming software. Please take a look at the relevant instructions in the online help of tools 8000.

Order Form for IQ8 Composed Languages (xy.SV99) - page 1/2

Honeywell Life Safety Austria GmbH

Fax +43 1 600 6030-900
hls-austria@honeywell.com

Customer Data Please fill out the following form for the registration of these data.

Company:	Customer ID:
.....
Street:	Zip Code/City:
.....
Contact Person:	E Mail:
.....
Telephone:	Fax:
.....
Order Number/Order Text:	
.....	

Order Combined Version

- ___ pcs. **802385.SV99** O2T/FSp multisensor detector IQ8Quad, customized version
- ___ pcs. **807386.SV99** O2T/Sp multisensor IQ8Quad, customized version
- ___ pcs. **807322W.SV99** IQ8Alarm Plus/SpSo sounder with speech, white, composed version
- ___ pcs. **807332R.SV99** IQ8Alarm Plus/Sp sounder with speech, red, customized version
- ___ pcs. **807372RR.SV99** IQ8Alarm Plus/FSpSo VAD with sound/speech, red/red, customized version
- ___ pcs. **807372RW.SV99** IQ8Alarm Plus/FSpSo VAD with sound/speech, red/white, customized version

Technical Specifications

File with announcements/signals sent to contact person in Neuss/Germany:

Contact Person:

Address:

E Mail:

Sample (extra charge) should be approved by (customer contact details):

Name:

Telephone:

Email:

Address:

Remark:

.....

Take note, these standards have to be followed:

- Files with speech and signal tones must be created locally
- max. length per announcement/signal tone is 25 seconds per file
- max. 5 announcements/signal tones can be programmed
- in total 169 sec. can be recorded on one IQ8Quad or IQ8Alarm Plus (incl. silent breaks)

Specifications for tone recording studio:

- WAVE or AIFF files mono with a sampling rate of 48kHz and a word width of 16-24bits
- Hi-pass: 220 Hz, 12 dB/oct.
- Lo-pass: 5 kHz, 12 dB/oct.
- Multi-band-compressor, 3-band
 - a. 25 Hz - 350 Hz. - 5,3 dB
 - b. 350 Hz - 5kHz. - 2,9 dB
 - c. 5 kHz - 18 kHz. - 6,4 dB
- Brickwall-limiter

Info:

Depending on the sound quality we might have to pass it through an EQ, to make some modifications.

Additional costs for recording and/or fine tuning will be charged once per new file with a first order! Second order with the same file without additional costs!

Repeat Orders or Additions For repeat orders or additions please give the Order No. or the serial number of the detector with special languages.

Order Number:

Serial Number:

.....
Date/Signature

To be filled out by Honeywell Life Safety Austria GmbH:
Please forward to Novar GmbH when filled out!

Order number:

Position:

Order Form for IQ8 Composed Languages (xy.SV99) - page 2/2

Number	1. Speech or signal tone	2. Speech or signal tone	3. Speech or signal tone	4. Speech or signal tone	3. Speech or signal tone
Unique file name					
Country Code acc. ISO 3166					
Language Code acc. ISO 639-1					
Original text or tone specifications					
Gender of speaker (for speech files)	<input type="checkbox"/> female <input type="checkbox"/> male	<input type="checkbox"/> female <input type="checkbox"/> male	<input type="checkbox"/> female <input type="checkbox"/> male	<input type="checkbox"/> female <input type="checkbox"/> male	<input type="checkbox"/> female <input type="checkbox"/> male
Time/length of file in sec.					
Speaker type	<input type="checkbox"/> native speaker <input type="checkbox"/> 2nd language speaker	<input type="checkbox"/> native speaker <input type="checkbox"/> 2nd language speaker	<input type="checkbox"/> native speaker <input type="checkbox"/> 2nd language speaker	<input type="checkbox"/> native speaker <input type="checkbox"/> 2nd language speaker	<input type="checkbox"/> native speaker <input type="checkbox"/> 2nd language speaker
Product line	<input type="checkbox"/> Fire Alarm System <input type="checkbox"/> PA/VA	<input type="checkbox"/> Fire Alarm System <input type="checkbox"/> PA/VA	<input type="checkbox"/> Fire Alarm System <input type="checkbox"/> PA/VA	<input type="checkbox"/> Fire Alarm System <input type="checkbox"/> PA/VA	<input type="checkbox"/> Fire Alarm System <input type="checkbox"/> PA/VA

Part Number Index

Part No.	Page	Part No.	Page	Part No.	Page	Part No.	Page
251-003	93	704148	224	761404.10	164	772478	18
013405.20	44	704900	97	761405.10	164	772479	18
013601	48	704901	97	761406	164	781335	33
013603	48	704902	97	761407	164	781336	33
013604	49	704903	97	761440	163	781337	33
013605	49	704904	97	761441	163	781463	150
013606	50	704910	100	761520.10	180	781464	151
013607	50	704911	101	761521.10	180	781465	152
013608	49	704912	101	761522.10	180	781466	151
013609	48	704915	100	761523.10	181	781467	152
013610	47	704917	101	761524.10	181	781468	152
013611	50	704950	107	761525.10	181	781469	152
013612	50	704951	107	761526.10	181	781470	152
013613	51	704952	107	761542.10	182	781482	85
013616	47	704953	107	761549	182	781550	86
013617	47	704954	107	761694	113	781682	102
013618	50	704960	111	764730	220	781692	102
013624	51	704964	111	764731	220	781693	103
013625	51	704965	112, 131	764732	220	781694	103
013626	48	704966	112	764733	221	781698	103
013631	47	704967	112, 139	764734	221	781699	103
013635	55	704975	111	764736	221	782302	143
013636	55	704980	108	764737	222	782306	144
013643	48	704981	108, 130	764744	78	782307	144
013650	51	704982	108	764745	78	782308	144
013652	51	704983	108	764752	79	782310	143
013653	52	704985	108	764754	79	782311	142
013655	52	736235	20	764790	36	782315	142
013661	49	743212	20	767010	214	783312	144
018001	34	743245	20	767017	214	783313	144
018002	34	743248	20	767030	216	784382.DO	19
018004	34	744027	21	767031	216	784725.PL	37
018006	34	744028	21	767153	215	784743.CZ	37
018007	34	744029	21	767813.10	217	784744	38
018009	34	744030	21	767814.10	217	784753	38
018011	34	761312	163	769910	102	784768	42
050510	223	761314	163	769911	102	784769	42
060426	87	761315	160	769914	20	784840.10	41
060427	88	761316	160	769915	21	784841.10	41
060429	93	761317	161	769916	102	784842	19
060431.10	93	761317.50	161	769921	100	784843	41
259529	82	761317.50.H	163	772386	44	784855	43
382040	222	761317.H	162	772387	44	784856	43
701040	100	761401.10	162	772445	20	784865	41
704070	101	761402.10	162	772476	18	784871	38
704147	224	761403	162	772477	18	784872	38

Part Number Index

Part No.	Page	Part No.	Page	Part No.	Page	Part No.	Page
786000	17	789864	24	804956	110	808610.10	125
786002	16	789866	24	804960.EX	115	808611.10	126
786100	17	796349	217	804961	106	808615	126
786102	16	800171	59	804961.EX	116	808619.10	127
786302	16, 17	800177	59	804970	104	808621	123
787531	19	800271	59	804971	105	808623	121
787532	19	800361.10	61	804973	105	808623.10	122
788012.40	25	800371	60	805550	90	808623.40	122
788013.40	25	800374	60	805551	89	808624	129
788013.40.RU	25	800375	60	805552	90	808625	129
788014.40	27	801711.10	169	805553	91	808626	129
788014.40.CZ	27	801722.10	169	805560	85	808626.10	129
788014.40.GB	27	802171	63	805570	83	808630.10	128
788014.40.PL	27	802177	63	805571	81	808631.10	128
788014.40.RO	27	802271	64	805572.50	84	850054	86
788014.40.RU	27	802371	64	805573	84	850055	86
788016	28	802373	64	805574	82	950101	180
788023.10	28	802379	151	805576	82	950104	180
788093	17	802382	71	805577	83	950107	180
788400	28	802383	71	805580	87	950110	181
788401	28	802384	71	805581	87	950113	181
788402	28	802385	72	805582	91	950116	181
788404	28	802385.SV98	72	805583	91	950119	180
788406	28	802385.SV99	72	805584	91	960000.10.GB	30
788600	225	802386	73	805585	92	960001.10.GB	30
788601	225	802386.SV98	73	805586	88	960002.10.GB	30
788602	223	802386.SV99	73	805587	81	960003.10.GB	31
788603.10	224	802473	66	805588	81	960004.10.GB	31
788605	224	803271.EX	75	805589	81	960005.10.GB	31
788606	44	803371.EX	75	805590	80	960006.10.GB	31
788612	129	803374.EX	76	805591	80	960007.10.GB	31
788650.10	225	804382.D0	19	805592	61	960008.10.GB	31
788651.10	225	804744	77	805593.10	135	960110	216
788652	223	804791	36	805594.10	136	960114	216
788653	28	804868	130	805595.10	137	960115	216
788654	28	804870	129	805597	34	960119	214
788655	226	804900	98	805601.10	138	960120	213
788656	226	804901	98	805602.10	139	960121	213
789300	11	804902	98	805603	139	960122	213
789301	11	804905	99	805604	140	960124	213
789302	12	804906	99	805605	140	960126	214
789303	15	804920.EX	117	808003	10	960127	215
789860.10	22	804924.EX	118	808004	15	960128	215
789861	22	804950	109	808139	10	960129	215
789862.10	23	804951	109	808219	15	960130	213
789863	23	804955	110	808606	124	970120.IN	153

Part Number Index

Part No.	Page	Part No.	Page	Part No.	Page
970121.IN	153	F-SP	182	VSP-850-G	179
970123.IN	153	F-SP-REFILL	182	VSP-962	179
970124.IN	153	FSX-A001	148	VSP-972	178
970125.IN	153	HLSPS-ADPTR	32	VSP-973	178
970126.IN	153	HLSPS-DB2	32	VSP-980-W	177
970129.IN	154	ISID-INST	167	VSP-980-W22	177
970130.IN	154	M200SMB	226	VSP-981-W	177
970132.IN	154	OSE-HPW	166	VSP-981-W22	177
970133.IN	154	OSE-SP-01	166	VSP-982-W	177
970134.IN	153	OSE-SPW	166	VSP-982-W22	177
970137	155	OSI-10	166	VSP-990-330	178
970138	154	OSI-90	166	VSP-991	178
970139	155	OSID-EHE	167	VSP-998	178
970139.IN	155	OSID-EHI	167	VSP-1000	178
970140.IN	158	PS200	118	VSP-1001	178
970142.IN	158	PSU-12	148	VSP-1002	178
970143.IN	158	SC070	118	VSP-1003	178
970144.IN	159	SH-001	148	VSP-1004	178
970145.IN	158	SM4	148	W1A-R1K0SG-E019-81	
970146.IN	156	SMB6-V0	226		114
970147.IN	157	TL-1055	148	W1A-R1K0SG-U007-01	
970148	157	TL-2055	148		113
970150.IN	156	VEA-040-A00	175		
970151	156	VEA-040-A10	175		
970151.IN	157	VEP-A00-1P	174		
970153.IN	156	VEP-A00-P	174		
970154	156	VEP-A10-P	174		
970154.IN	157	VER-A40-40-STX	176		
970165.IN	157	VEU-A00	173		
970166	154	VEU-A10	173		
970167	154	VHX-0200	179		
BME2Z002	24	VLF-250-01	171		
E700-SP-DCL	182	VLF-500	171		
F-BO-AFE70-2	170	VLI-880	172		
F-INF-25	170	VLI-885	172		
F-INF-25-RF	170	VPS-220-STX	176		
FL-IF-6	169	VPS-220-STX-SLV	176		
FS20X-211-23-6	146	VPS-250-STX	176		
FS20X-211-24-6	146	VPS-250-STX-SLV	176		
FS24X-211-24-6	145	VRT-300	179		
FS24X-911-23-6	145	VSP-005	179		
FSL100-IR3	147	VSP-030	172		
FSL100-SM21	149	VSP-031	172		
FSL100-TL	149	VSP-032	172		
FSL100-UV	147	VSP-034	172		
FSL100-UVIR	147	VSP-850-4	179		

Index

Keyword	Page
2 sensor channels for Honeywell DTS detector	154
3.6 V Lithium battery	34
3-relay common fault module	19
3-relay module	19
4 sensor channels for Honeywell DTS detector	154
4" trim ring and snap-in mounting clips for IQ8Quad detector base	82
8-fuse-card	222
19" rack mounting kit for SZI 192 detector zones	17
45° angle (ABS) for 25 mm pipe	181
45° angle (PVC) for 25 mm pipe	180
90° angle (ABS) for 25 mm pipe	180
90° angle (PVC) for 25 mm pipe	180
90° bend (ABS) for 25 mm pipe	180
90° bend (PVC) for 25 mm pipe	180
110/220VAC wallcharger test lamp	148

A

Adapter for pole 769813	87
Adapter module ADP-N3E	38
Adapter module ADP-PRS-422	38
Addressable MCP, IP66	113
Air filter for VESDA aspirating systems	179
Alarm and monitoring module for IQ8FCT XS, IQ8FCT LP	129
Analog loop module	19
Analog loop module powered loop (PL)	19
Anchor plate DH50-AP-S	216
Anchor plate DH70-AP-S	216
Anchor setting tool	159
ASD FFAST LT-200 EB, dual channel	169
ASD FFAST LT-200 EB, single channel	169
ATEX, IECEx certification for Honeywell DTS detector	154

B

Banderolen zur Markierung der Ansaugpunkte	182
Base cover for IQ8Quad	81
Base module for OVP modules	222
Basic license for WINMAGplus USB port	47
Battery 12 V DC/1.2 Ah capacity	34
Battery 12 V DC/2.1 Ah capacity	34
Battery 12 V DC/7 Ah capacity	34
Battery 12 V DC/12 Ah capacity	34
Battery 12 V DC/17 Ah capacity	34
Battery 12V DC/24Ah capacity	34

Keyword	Page
Battery 12 V DC/38 Ah capacity	34
Battery extension housing	11
Blow off device for pipe system	170

C

Cable gland for housing 764752	79
Cable gland M12 with nut	224
Cable gland M16 with nut	224
Cable glands M20 f. weather protection housing	152
Carrying bag for test equipment	88
Ceiling holder for LRMX, for distances from 40 to 70 cm	164
Ceiling holder for LRMX, for distances from 70 to 150 cm	164
Ceiling lead-through adapter (ABS)	182
Ceiling pendant mount for Fireray	163
CO capsule for multi-stimulus detector tester 805551	91
Connection server developers kit	50
Control center software CD WINMAGplus basic kit	47
Conventional Ex MCP, IP67, small housing, red	114
Conventional MCP compact, small, red, glass pane	104
Conventional MCP electronic module	98, 109
Conventional MCP electronic module with 2nd micro-switch	98
Conventional MCP electronic module, with 2nd micro-switch	109
Conventional MCP electronic module w/o snap-on function	98
Conventional MCP, IP67, small housing, red	113
CO test gas for smoke detector tester 805582	91
Cutting tool for FO steel sensor cable 970153.IN	157

D

Data points package	50
DC/DC converter 12 V/24 V DC	33
DC/DC converter output voltage 12 V DC	33
DC/DC converter output voltage 24 V DC	33
Detector base with relay contact for IQ8Quad	80
Detector base with relay output for ES Detect 800631.10	61
Detector cover for IQ8Quad with built-in alarm sounder	81
Detector cover for IQ8Quad w/o built-in alarm sounder	81

Index

Keyword	Page
Detector removal tool	87
Door magnet with distance pipe incl. flexible anchor, 400 N, 175 mm	213
Door magnet with distance pipe incl. flexible anchor, 400 N, 325 mm	213
Door magnet with distance pipe incl. flexible anchor, 400 N, 475 mm	213
Door magnet with release button incl. flexible anchor, 400 N	213
Door magnet with release button incl. flexible anchor, 800 N	214
Door magnet w/o release button incl. flexible anchor, 400 N	213
Door retainer DH50-N490-UM	214
Door retainer DH50-N490-WM	214
Double head cable ties, 500 pcs	157
DTS evaluation unit warranty extension from 1 to 3 years	154
DTS evaluation unit warranty extension from 1 to 5 years	154
Dummy cover 19", 2 HU	21
Dummy cover 19", 3 HU	21
Dummy cover 19", 5 HU	21
Dummy cover 19", 9 HU	21
E	
E2000 APC 8° pigtail, 5 m	157
EMV isolator for IQ8Quad, ES Detect detector base	85
End cap (ABS) for 25 mm pipe	181
End cap (PVC) for 25 mm pipe	181
EOL-I terminating device	129
EOL-O terminating device	129
EOL-UV terminating device (UniVario)	129
EOL-Z module for detector groups	129
esserbus alarm transponder, 4 IN/2 OUT with isolator	121
esserbus communication transponder for ECP 8010	126
esserbus FSA transponder for fire doors	127
esserbus transponder 12 relays (8 bit)	125
esserbus transponder 32 LED	126
esserbus transponder for special detectors	122
esserbus transponder for UniVario with isolator	122
esserbus transponder IQ8FCT LP	123
esserbus transponder IQ8FCT XS	124
esserbus transponder RZT, 12 V	128

Keyword	Page
esserbus transponder RZT, 24 V	128
essernet® module, 62.5 kBd for IQ8Control	41
essernet® module, 500 kBd for IQ8Control	41
essernet repeater, 62.5 kBd	41
essernet repeater, 500 kBd	41
Ex barrier for intrinsic safe detectors Series IQ8Quad Ex (i)	77
Ex barrier for intrinsic safe detectors Series IQ8Quad Ex (i) and 9100	78
Ex door magnet, 1588 N	215
Extension housing	15
Extension housing for batteries with 192 detector zones	11
Extension housing for SZI 192 detector zones, IQ8Control	12
Extension module with 1 additional micromodule slot	18
Extension module with 3 additional micromodule slots	18
External power supply 2 A / 24 V DC 17Ah EN 54-4	30
External power supply 3 A / 24 V DC 17Ah EN54-430	30
External power supply 3 A / 24 V DC 28Ah EN 54-4	30
External power supply 5 A / 24 V DC 17Ah EN 54-4	31
External power supply 5 A / 24 V DC 28Ah EN 54-4	31
External power supply 5 A / 24 V DC 40Ah EN 54-4	31
External power supply 7 A / 24 V DC 17Ah EN 54-4	31
External power supply 7 A / 24 V DC 28Ah EN 54-4	31
External power supply 7 A / 24 V DC 40Ah EN 54-4	31
External power supply DB2	32
External power supply DCU 2403	32
Extinguishing control panel 8010 Series 4 with operating unit, Czech	27
Extinguishing control panel 8010 Series 4 with operating unit, Polish	27
Extinguishing control panel 8010 Series 4 with operating unit, Romanian	27
Extinguishing control panel 8010 Series 4 with operating unit, Russian	27
Extinguishing control panel, Series 4, English	27

Index

Keyword	Page
Extinguishing control panel, Series 4, German	27
Extinguishing panel 8010, Series 4, with operating unit, German	25
Extinguishing panel 8010, Series 4, with operating unit, Russian	25
Extinguishing panel 8010, Series 4, w/o operating unit	25
F	
FACP IQ8Control C	10
FACP IQ8Control C for 19" rack	10
FACP IQ8Control M	15
FACP IQ8Control M for 19" rack	15
FB information and operating system, DIN A4, Polish	37
Field bus interface PLus	23
Filler panel front, neutral	17
F-INF-25 FFAST external pipe filter	170
Fire department indicating panel FAT3000, Czech	37
Fireray 50 RV with one prism	160
Fireray 100 RV with four prisms	160
Fireray 5000 detector head	162, 163
Fireray 5000, line smoke detector, incl. controller, 50 m	161
Fireray 5000, line smoke detector, incl. controller, 100 m	161
Fixed heat detector ES Detect	59
Fixed heat detector ES Detect, Class B	59
Fixed heat detector IQ8Quad (class B), with higher operating temperature with isolator	63
Fixed heat detector IQ8Quad with isolator	63
Flexible keeper plate for door magnets, Ø 55 mm	216
Flexible keeper plate for door magnets, Ø 75 mm	216
Floor mounted bracket for door magnet 960119 and 960120	215
Flush mount kit for base IQ8Quad	81
Flush mount release pushbutton for automatic door release system, German	217
Foil for front face with universal text for large MCP	
ABS, black lettering	101
FO sensor cable Safety FRNC	156
FO sensor cable Steel FRNC	156
Front foil with universal text for large MCP ABS, white lettering	101
FS20X-211 IR/UV AL M25 FM/EN54	146
FS20X-211 IR/UV SS M25 FM/EN54	146
FS24X-911 3IR AL M25 FM/EN54	145

Keyword	Page
FS24X-911 3IR SS M25 FM/EN54	145
FSL100 swivel mount	149
FSL100 test lamp, charger & case; non EX	149
FSX kit with Interface, RS485, USB cables	148
H	
Hardware option TCP/IP converter, Ethernet RS232 / RS485	44
Heat detector UniVario	143
Heat detector UniVario, 2 m	144
Heat detector UniVario, 6 m	144
Heat detector UniVario, 9 m	144
Heat detector UniVario, 200 mm	143
High dense I/O connection set with connection block	155
High dense I/O connection set with open end	155
High IP housing	226
Housing flush mount, gray	225
Housing flush mount, white	225
Housing for Ex barrier	79
Housing for SEI	44
Housing for small MCP, blue, similar to RAL 5015107	107
Housing for small MCP, green, similar to RAL 6002	107
Housing for small MCP, orange, similar to RAL 2011	107
Housing for small MCP, red, similar to RAL 3020	107
Housing for small MCP, yellow, similar to RAL 1021	107
Housing surface mount, gray	225
Housing surface mount, white	225
I	
Indicating and operating panel for ECP 8010, Czech	28
Indicating and operating panel for ECP 8010, English	28
Indicating and operating panel for ECP 8010, German	28
Indicating and operating panel for ECP 8010, Polish	28
Indicating and operating panel for ECP 8010, Romanian	28
Interface-Module RS232 / V24	44
Interface module TTY/CL 20 mA	44
IP42 damp room base adapter for IQ8Quad, ES Detect detector base	84

Index

Keyword	Page
IP43 protection for detector base IQ8Quad, deep design	84
IP43 protection for detector base IQ8Quad, flat design	83
IP54 kit for large MCP 7048xx	101
IP55 base adapter for 788656	226
IP55 kit for protective cover	103
IP66 housing for OSID image sensor (imager)	167
IP66 housing for OSID standard light source (emitter)	167
IQ8MCP compact IP 66, small, red, with isolator glass pane	106
IQ8MCP compact, small, red, with isolator and glass pane	105
IQ8MCP compact, small, red, with resettable element	105
IQ8MCP electronic module	110
IQ8MCP electronic module with isolator	99
IQ8MCP electronic module w/o isolator, with relay	99, 110
IQ8Quad and ES Detect detector heating element	82
IQ8TAL with isolator, 1 contact IN/1 OUT	130
IQ8Wireless cover for wireless interface, red and white	140
IQ8Wireless detector base	135
IQ8Wireless gateway for devices	136
IQ8Wireless mounting frame for IQ8Quad detectors, white	140
IQ8Wireless mounting frames for IQ8Alarm, red and white	139
IQ8Wireless transponder for devices, wall mount	137
IQ8Wireless universal interface w/o cover, red	138
IQ8Wireless universal interface w/o cover, white	139
IR3 flame detector RED, ATEX, FM, EN54	147
ISID-INST	167
Isolation and assembly block for safety Ex barrier	78
K	
Kit for suspended installation	85
L	
Label for release pushbutton	217
Label plate for detector base IQ8Quad	82
Large Conventional MCP Ex (i) IP 66/67, red with glass pane	117
Large IQ8MCP Ex (i), red with glass pane	118
Lever lock - type 17 for key no. 801	20

Keyword	Page
Lever lock - type for key no. 901	20
License Modbus TCP/IP interface	154
Line heat detector Honeywell DTS - evaluation unit, distance range 1 km	153
Line heat detector Honeywell DTS - evaluation unit, distance range 2 km	153
Line heat detector Honeywell DTS - evaluation unit, distance range 4 km	153
Line heat detector Honeywell DTS - evaluation unit, distance range 6 km	153
Line heat detector Honeywell DTS - evaluation unit, distance range 8 km	153
Line heat detector Honeywell DTS - evaluation unit, distance range 10 km	153
Loop isolator for transponder	129
Loop LED remote indicator panel for 32 messages	36
M	
M200SMB	226
Management software WINMAGPlus licence for Honeywell DTS detector	49
Master box interface module, 8007/8008, ESSER	19
MCP housing large with glass pane, blue, similar to RAL 5015	97
MCP housing large with glass pane, green, similar to RAL 6002	97
MCP housing large with glass pane, orange, similar to RAL 2011	97
MCP housing large with glass pane, red, similar to RAL 3020	97
MCP housing large with glass pane, yellow, similar to RAL 1021	97
Metal key for large MCP	102
Micro splice-box IP20 for Honeywell DTS sensor cables	156
Module housing for top-hat mounting rail	224
Module with interface M4-TTY	38
Module with RS422/RS485 interface	38
Mounting adapter for intermediate ceilings	83
Mounting bracket for UniVario flame detectors	144
Mounting frame 19" IQ8Control C/M	20
Mounting frame for small MCP, red and white	112, 139
Mounting kit	224
Mounting plate for ceiling bracket for detector/single reflector	164

Index

Keyword	Page
Mounting rail for FACP	223
Mounting set for LKM 781463	152
Mounting spider for ceiling bracket	164
Multimode FO converter ST	42
Multiple-sector interface in housing	28
Multi-stimulus detector tester TF 1001	90
Multi-stimulus detector tester TF 2001	89
N	
Network interference suppression filter type 2VK3	223
O	
O2T/F multisensor IQ8Quad	71
O2T/FSp multisensor detector IQ8Quad, customized version	72
O2T/FSp multisensor detector IQ8Quad with composition of other languages	72
O2T/FSp multisensor IQ8Quad	72
O2T multisensor detector ES Detect	60
O2T multisensor fire detector IQ8Quad Ex (i) w/o isolator	76
O2T multisensor fire detector IQ8Quad with isolator	65
O2T/So multisensor IQ8Quad	71
O2T/Sp multisensor IQ8Quad	73
O2T/Sp multisensor IQ8Quad, customized version	73
O2T/Sp multisensor IQ8Quad, special language	73
Operating foil for large MCP 80490x, neutral	100
Operating front, English	16
Operating front for printer and w. take-up reel, English	16
Operating front with single zone indication 64, English	16
Optical Smoke Detector Detect ES with relay contact, 48 V DC operation	61
Optical smoke detector ES Detect	60
Optical smoke detector IQ8Quad Ex (i) w/o isolator	75
Optical smoke detector IQ8Quad with isolator	64
Option – ability for customized interface rights (client-side)	51
Option – client	51
Option control group indication and alarm counter for ECP 8010, German	28
Option – escalation	51
Option IP55 shrink sleeve for large MCP 80490x 101	101

Keyword	Page
Option - notification	51
Option – redundance	51
OSID Emitter, high power	166
OSID Emitter standard power	166
OSID Emitter standard power, battery version	166
OSID Imager - 7° coverage	166
OSID Imager - 80° coverage	166
OSID installation kit	167
O/So optical smoke detector IQ8Quad	71
OTblue-LKM multisensor fire detector IQ8Quad with isolator	151
OTblue multisensor detector ES Detect	60
OTblue multisensor fire detector IQ8Quad with isolator	65
OTG multisensor fire detector (CO) IQ8Quad with isolator	66
OT multisensor fire detector IQ8Quad with isolator	64
"Out of order" sign, multilingual for 7047xx, 7048xx and 70490x	100
OVP module	221
OVP module for control outputs	221
OVP module for esserbus/esserbus-PLUS loop	221
OVP module for essernet and RS485 interfaces	220
OVP module for TTY interfaces and conventional zones	220
OVP module including base support for 230 V power supply line	220
P	
Peripheral module	18
Peripheral module with 1 additional micromodule slot	18
Pipe (ABS), diameter 25 mm	180
Pipe (PVC), diameter 25 mm	180
Plastic clamp set (100 pc.) - dowels in stainless steel	158
Plastic clamp set (100 pc.) - dowels in zinc-plated steel	158
Plastic key for large MCP	102
Plastic spare key for small MCP	112
Plastic telescopic extension	87
Plastic telescopic rod	88
Plate for 1 prism	163
Plate for 4 prism	163
Programming cable for ECP 8010	24
Programming software tools 8000	22

Index

Keyword	Page
Protective cage	86
Protective cover for manual call points, English	103
Protective cover for manual call points, German	103
Protective kit for MCP and TAL, transparent	112, 131

R

19" rack mounting kit for SZI 192 detector zones	17
Rate-of-rise detector ES Detect	59
Rate-of-rise heat detector IQ8Quad Ex (i) w/o isolator	75
Rate-of-rise heat detector IQ8Quad with isolator	64
Reflector set for LRMX, for ranges of up to 80 m	162
Reflector set for LRMX, for ranges of up to 100 m	162
3-relay common fault module	19
3-relay module	19
Relay controller set for Honeywell DTS detector	154
Relays extension set for Honeywell DTS detector	155
Replacement filter for VSP-850-G	179
Replacement filter mats for F-INF-25 (1 set)	170
Replacement integral filter for FAAST LT-200 EB	169
Resettable element for small MCP	111

S

SEI serial essernet interface EDP, bidirectional	43
SEI serial essernet interface EDP, unidirectional	43
Sensor cable connectors for FO sensor cable, 970150.IN	156
Sensor cable connectors for FO sensor cable, 970153.IN	156
Sensor cable heating testing tool	157
Serial connecting cable for 789862.10	24
Service key for electronic module (Part No. 80490x)	102
Singlemode FO converter ST	42
Single reflector for LRMX	162
Sleeve (ABS) for 25 mm pipe	181
Sleeve (PVC) for 25 mm pipe	181
SM4	148
Small Conventional MCP Ex (i) IP 66/67, red with glass pane	115
Small IQ8MCP Ex (i) IP 66/67, red with glass pane	116
Smoke capsule for multi-stimulus detector tester, 805550/51	90
Smoke detector tester	91
Smoke pellets for testing purposes	93
Smoke pen	182

Keyword	Page
Smokesabre test gas for smoke detectors	92
Spare battery baton	93
Spare filter for air duct detector UG7	151
Spare glass pane for MCP housing 70490x, 7048xx und 761694	100
Spare glass pane for small MCP, EN54	111
Spare glass pane for small MCP, EN54, neutral	111
Spare glass pane red for MCP housings 7047xx and 7048xx	100
Spare key 1D009 for FACP	20
Spare key 801 for FACP	20
Spare key 901 for FACP	21
Spare keys pack for MCP W1A	118
Spare wicks for Smoke pen (Part No. F-SP)	182
Special painting IQ8Quad	86
Special painting IQ8Quad detector base	86
Splice-box IP67 for Honeywell DTS sensor cables	157
Stainless steel clamp set (100 pc.) - dowels in stainless steel	158
Standard base UniVario	144
Standard detector base for IQ8Quad	80
Standard LED remote indicator panel	36
Starter kit equipment PPlus with programming software tools 8000	22
Steel clamp set (100 pc.) - dowels in zinc-plated steel	158
Suctions hose set for 25 mm pipe	182
Sun shield SS SS2/SS4/FS24X	148
Surface mount housing for 6 IQ8FCT XS modules	226
Surface mount housing for small MCP and TAL, blue, similar to RAL 5015	130
Surface mount housing for small MCP, blue, similar to RAL 5015	108
Surface mount housing for small MCP, gray, similar to RAL 7035	108
Surface mount housing for small MCP, orange, similar to RAL 2011	108
Surface mount housing for small MCP, red, similar to RAL 3020	108
Surface mount housing for small MCP, yellow, similar to RAL 1021	108
Surface mounting housing for one IQ8FCT XS module	226
Surface mount release pushbutton for automatic door release system, German	217

Index

Keyword	Page
Surface spacer for protective cover	103
Switched-mode power supply with cylindrical plug	24
Swivel mount	148
SZI front for 192 detector zones	17

T

Terminal card for panel 8010 in 19" rack, 1 m	28
Terminal card for panel 8010 in 19" rack, 2 m	28
Test gas for smoke detector tester 805582	91
Test head for heat detector together with battery and charger	93
Test lamp FS18X/FS20X/FS24X EXP	148
Test lamp FS18X/FS20X/FS24X NON-EXP	148
Three-channel infrared flame detector UniVario	142
Top-hat rail	223
T-Piece (ABS) for 25 mm pipe	181
T-Piece (PVC) for 25 mm pipe	181
Transparent cover for MCP W1A	118

U

Univ. bracket for F5000 or prism plate	
761440/761441	163
USB cable A/B for 789862, 10 field bus and panel interface	23
UV flame detector RED, ATEX FM EN54	147
UV flame detector UniVario	142
UV/IR flame detector RED, ATEX FM EN54	147

V

VEA 4 mm Microbore Tube (UL) Rated 150 m	178
VEA 4 mm to 4 mm Joiner Right Angle 10 Pac	178
VEA 6 mm Microbore Tube (UL) Rated 100 m	178
VEA 6 mm to 4 mm Reducer 10 Pack	178
VEA 6 mm to 6 mm Joiner Right Angle 10 Pac	178
VEA 6 mm to 6 mm Joiner Straight 10 Pack	178
VEA Blanking Plug 6mm 50 Pack	178
VEA Filter	178
VEA Pump	178
Venturi air duct module for IQ8Quad OTblue-LKM	
	150
Venturi tube, 0.6 m	151
Venturi tube, 1.5 m	152
Venturi tube, 2.8 m	152
VESDA 300 PC interface	179
VESDA-E STX PSU 0.5A 14AH, black	176
VESDA-E STX PSU 0.5A 14AH, silver	176
VESDA-E STX PSU 2A 24AH, black	176

Keyword	Page
VESDA-E STX PSU 2A 24AH, silver	176
VESDA-E VEA 4 mm Standard Sampling Point white	
	177
VESDA-E VEA 6 mm Standard Sampling Point white	
	177
VESDA-E VEA 6 mm Surface Mount Sampling Point white	177
VESDA-E VEA-40 Aspirating Smoke Detector	175
VESDA-E VEA-40 Detector with 3.5" Display	175
VESDA-E VEA 40 relay extension StaX	176
VESDA filter for VEU, VEP	179
VESDA filter for VLP, VLS, VLF, VLC	179
VESDA intelligent filter spare part	172
VESDA LaserFocus VLF-250-01	171
VESDAnet™ connection box	179
VESDA VEP 1 pipe with LEDs	174
VESDA VEP 4 pipe with display	174
VESDA VEP 4 pipe with LEDs	174
VESDA VEU with Display	173
VESDA VEU with LEDs	173
VESDA VLF-500	171
VESDA VLI Relay only	172
VESDA VLI with VesdaNet	172
VLI Aspirator Spare Part	172
VLI Secondary Filter Spare Part	172
VLI VESDANET CARD	172

W

Wall and floor swivel bracket for door magnet 960119 and 960120, angled, 150 mm	215
Wall and floor swivel bracket for door magnet 960119 and 960120, angled, 300 mm	215
Wall mounted door magnet w/o release button, 490 N	214
Wall mount housing IP66 for Honeywell DTS detector	153
Weather protection housing for air duct detector	152
Weather protective cover for MCP housings	
7047/48xx, blue	102
Weather protective cover for MCP housings	
7047/48xx, red	102
WINMAG installation upgrade as of version 6	47
WINMAGLite upgrade to WINMAGplus full version 55	
WINMAGLite with USB dongle	55
WINMAGplus – 4-monitor support option	52
WINMAGplus – AutoCAD option	52
WINMAGplus control center software - subsequent	

Index

Keyword	Page
upgrade.....	48
WINMAGplus license - access control.....	48
WINMAGplus license connection server.....	50
WINMAGplus license - fire detection technology.....	48
WINMAGplus license - Galaxy Dimension.....	48
WINMAGplus license - intrusion detection techno- logy.....	48
WINMAGplus license – OPC client.....	50
WINMAGplus license – OPC server.....	50
WINMAGplus license - rescue route technology/ escape door control.....	49
WINMAGplus license - RTD.....	49
WINMAGplus license - video technology.....	49
WINMAG upgrade to WINMAGplus.....	47

1

2

3

4

5

6

7

8

9

10

11

12

13

14